

# VRF multi-system Air-Conditioners Catalogue

# **KXZ** series

2026



**KXZ2** series  
Flexible design

**New KXZ3** series  
R32 VRF multi-system Air-Conditioners

# New Climate & Energy Solution

The new Mitsubishi Heavy Industries KXZ VRF series delivers high performance in cooling and heating for all commercial applications.

The KXZ series provides the highest level of design flexibility, efficiency as well as operational functions. This brochure highlights the key benefits and new and improved functions of our latest VRF technology.



## 2025 Design Award



reddot winner 2025

The RC-ES1 Series has been honored with the prestigious Red Dot Design Award 2025 in the Product Design Category.



The RC-ES1 Series has been honored with the prestigious Gold A' Design Award in the Repair, Restoration, and Maintenance Products Design Category.

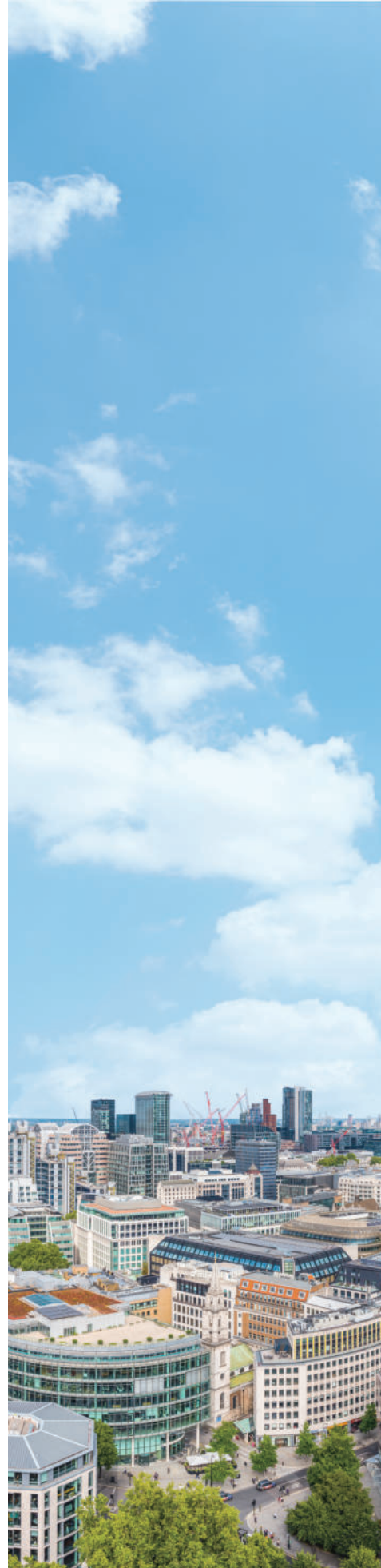

Harmonize with the world  
with the earth, people, buildings

Line-Up

# KXZ3

FDC-KXZE3  
FDC-KXZE3A

- Global Environment
- Wide Design Flexibility
- Improved Energy Efficiency
- Wellness & Comfort
- Toughness
- Serviceability

Small Capacity Model      **New** Medium Capacity Model      **New** Large Capacity Model



# KXZ2

FDC-KXZE2

Heat Recovery Systems

FDC-KXZRE2



# Micro KXZ

FDC-KXZES1-W  
FDC-KXZEN1-W  
FDC-KXZES1  
FDC-KXZEN1  
FDC-KXZME1  
FDC-KXZEME1A



# KXZ Lite

FDC-KXZPE1



# KXZ

Water cooled series

FDC-KXZWE1



## CONTENTS





















<b>Introduction</b> .....	2
<b>Outdoor units</b> .....	4
KXZ3 series .....	8
KXZ2 series .....	38
KXZ2 series Heat Recovery Systems .....	48
Micro KXZ series .....	60
KXZ Lite series .....	65
KXZ series Water cooled series .....	66

<b>Indoor units</b> .....	72
Ceiling Cassette .....	86
Duct Connected .....	96
Wall Mounted .....	103
Ceiling Suspended .....	105
Floor Standing .....	106
Outdoor Air Processing unit .....	108
Hydro Module unit .....	110

<b>Ventilation</b> .....	112
Fresh Air Ventilation and Heat Exchange unit .....	112
Fresh Air DX Assembly .....	113
<b>Electronic Expansion Valve Kit</b> .....	114
<b>Control Systems</b> .....	116
<b>IoT Remote monitoring system</b> .....	124
<b>Building Management Systems</b> .....	126
<b>Support tool</b> .....	128
<b>Exterior dimensions</b> .....	130



# Outdoor units

Capacity	HP	4	5	6	8	10	12	14	16	17	18	19	20	22	24	26	28	30
	kW	12.1	14.0	15.5	22.4	28.0	33.5	40.0	45.0	47.5	50.0	53.0	56.0	61.5	67.0	73.5	80.0	85.0
<b>KXZZ3 New</b>  <p><b>Standard</b></p> <ul style="list-style-type: none"> <li>High efficiency</li> <li>Design flexibility</li> <li>VTCC+</li> <li>Advanced Continuous heating</li> </ul> 					S	S	S	M	M		M	L	L	L	L	S +	M +	M +
										S +	S +		S +	S +	S +	S +	S +	S +
<b>KXZZ3 New</b>  <p><b>Hi-COP combination</b></p> <ul style="list-style-type: none"> <li>High efficiency</li> <li>Design flexibility</li> <li>VTCC+</li> <li>Advanced Continuous heating</li> </ul> 									S +	S +		S +	S +	S +	S +	S +	S +	S +
<b>KXZZ2</b>  <p><b>Standard</b></p> <ul style="list-style-type: none"> <li>Wide range of operation</li> <li>Large capacity outdoor unit (Up to 60HP)</li> <li>VTCC • Continuous heating</li> </ul> 					S	S	L	L	L	L			L	S +	S +	S +	L +	L +
<b>KXZZ2</b>  <p><b>Hi-COP combination</b></p> <ul style="list-style-type: none"> <li>Higher energy savings</li> <li>VTCC</li> <li>Continuous heating</li> </ul> 													S +					S +
<b>KXZZ2</b>  <p><b>Heat Recovery</b></p> <ul style="list-style-type: none"> <li>High efficiency in simultaneous cooling and heating mode</li> <li>Wide range of operation</li> <li>VTCC • Continuous heating</li> </ul> 					S	S	S	L	L	L	L		L	L	L	S +	L +	L +
<b>KXZZ2</b>  <p><b>Heat Recovery Hi-COP combination</b></p> <ul style="list-style-type: none"> <li>High efficiency in simultaneous cooling and heating mode</li> <li>Higher energy savings</li> <li>VTCC • Continuous heating</li> </ul> 									S +	S +			S +	S +	S +	S +	S +	S +
<b>Micro KXZ</b>  <ul style="list-style-type: none"> <li>Space saving</li> <li>Slim, light</li> <li>Available in 1-Phase and 3-Phase</li> <li>Small, Medium building</li> </ul> 		●	●	●														
<b>Micro KXZ</b>  <ul style="list-style-type: none"> <li>Space saving</li> <li>Large number of connectable indoor units (Up to 24 Units)</li> <li>Small, Medium building</li> <li>Available in 1-Phase and 3-Phase (4-12HP)</li> </ul> 		●	●	●	●	●	●											
<b>KXZZ Lite</b>  <ul style="list-style-type: none"> <li>Space saving</li> <li>High efficiency</li> <li>Easy transportation &amp; Installation</li> </ul> 					●	●												
<b>KXZZ Water cooled series</b>  <ul style="list-style-type: none"> <li>High efficiency</li> <li>Low noise operation</li> <li>Individual control building, Large building</li> </ul> 					●	●	●		● +	● +			● +	● +	● +	● +	● +	● +



# VRF MULTI SYSTEM

The KXZ is a Variable Refrigerant Flow (VRF) multi-system air conditioner from Mitsubishi Heavy Industries, designed to deliver superior cooling and heating performance for a wide range of commercial application.



## Diverse Lineup

With **capacities ranging from 4HP to 72HP**, configurations can include either a single outdoor unit or combinations of up to three units to meet varying cooling and heating demands. A diverse selection of indoor units is also available, tailored to suit different applications and capacity requirements.

## Exceptional Design Flexibility

KX series range includes compact units, such as **the Micro KXZ series, ideal for small installation spaces**, as well as larger units like **the KXZ2 and KXZ3 series, featuring an extended total refrigerant piping length of up to 1,000 meters**. This versatility makes the range suitable for a variety of applications, from small and medium-sized buildings to large structures.

## Heat Recovery Technology

(Available on certain models)

These systems **provide both heating and cooling to individual indoor units** based on specific room requirements. Heat generated during the cooling process is efficiently re-purposed as a heat source for heating, delivering significant energy savings.

## Low GWP Refrigerant

(KXZ3 and Micro KXZ series)

The KXZ3 utilizes R32 refrigerant, which has a **GWP of 675—approximately one-third that of the conventional R410A refrigerant (GWP 2088)**. This transition significantly reduces environmental impact, helping you achieve your net zero goals.

## Sleek Design, that Harmonize With Buildings

(KXZ3)

The KXZ3 series has been designed to incorporate a blue ornamentation that creates a cohesive look when installed consecutively, resulting in **a modern aesthetic that blends seamlessly with any building**.

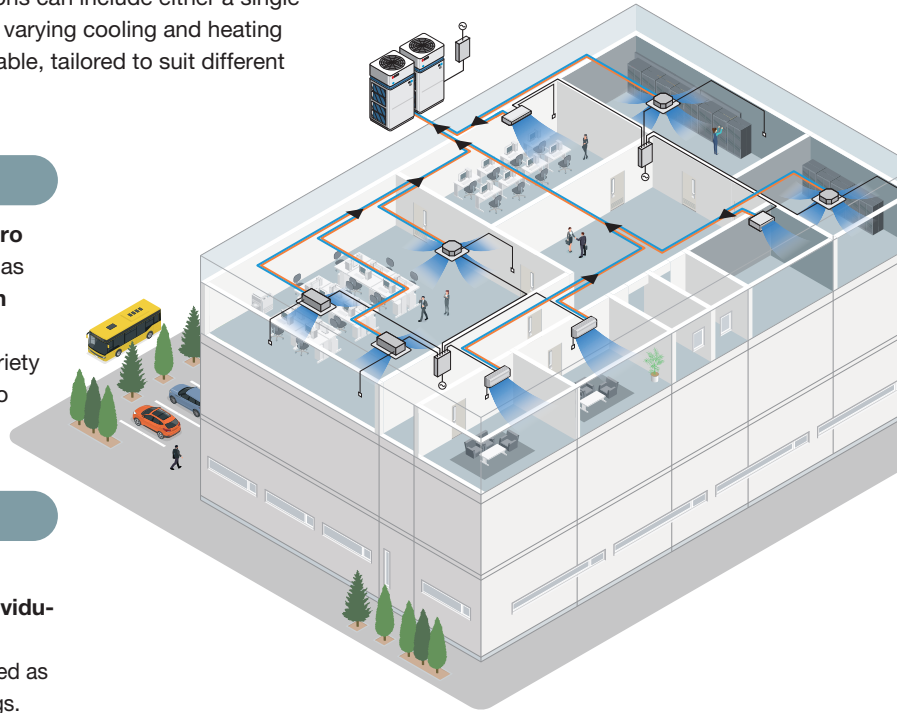

As part of its mission, the Mitsubishi Heavy Industries Group will continue driving innovation to achieve net-zero emissions society.

Mitsubishi Heavy Industries Thermal Systems, Ltd., a part of Mitsubishi Heavy Industries (MHI) Group, will contribute to the establishment of a sustainable society by underpinning industries and people's daily lives, by providing environmentally friendly thermal solutions that meet diverse market needs.



# Development History of the MHI's VRF KX Series

MHI's VRF systems have a long history dating back to 1984. For the global market, the first lineup, the **KX Series**, was introduced in 1994. The upward flow type has continuously evolved, and now, with the introduction of the new mid- and large-capacity models, the **KXZ3 Series** represents the latest stage of this evolution.



## VRF System Installation by Mitsubishi Heavy Industries Thermal Systems

Case study : **Education**



We're proud to have equipped Crossways Academy in Lewisham with our advanced VRF system, creating a more comfortable and conducive learning environment.

Maintaining an optimal temperature in spaces occupied by large groups of students presents unique challenges. These include frequent entry and exit movements, heat fluctuations from IT equipment, and managing glare with electric blinds.

The Mitsubishi Heavy Industries Thermal Systems VRF KX system offers an efficient solution. The building incorporates natural ventilation with electronically operated windows, and the air conditioning system is seamlessly integrated to automatically shut down when windows are open.

Specifically designed for retrofit applications, the VRF KX system delivers flexibility, energy efficiency, and comfort, making it the perfect fit for modern educational spaces.

Case study : **Hotel and Leisure**



Mitsubishi Heavy Industries (MHI) Thermal Systems' VRF heat recovery systems, part of the KX range, are expertly designed to meet the demanding needs of luxury hotels and high-traffic spaces like airport-style bus stations. Featuring advanced inverter technology, these systems adjust compressor output in real-time to precisely align with the cooling or heating demands of indoor units. This ensures maximum comfort and energy efficiency in even the most challenging environments.

By choosing our versatile heating and cooling solution, you're not only reducing energy consumption but also gaining fine-tuned control over room temperatures. Our system allows for customized heating and cooling in different areas based on specific needs.

For example, in sun-exposed, south-facing rooms where temperatures tend to rise, you can easily increase the cooling to maintain comfort. In contrast, in cooler or shaded areas, the system efficiently adjusts to provide necessary heating, ensuring a consistent and comfortable environment throughout the space.

This flexibility empowers you to optimize energy usage based on varying environmental conditions, improving both comfort and efficiency across your entire building.

# KXZ3 series

# KXZ3

The redesigned model with R32 refrigerant has been engineered by the following 6 concepts.

## New Design - 6 concepts -

### 1 Global Environment

- Reduce CO2 emission by about 70%

### 2 Wide Design Flexibility

- New exterior design to fit the scenery
- Various types of indoor units available
- Wider limitation of piping installation
- Flexible selection of safety systems

### 3 Improved Energy Efficiency

- Higher SCOP & SEER
- New R32 scroll compressor
- Heat exchanger with small heat transfer pipe
- Optimized fan and flow path design
- VTCC+ : advanced variable temperature and capacity control

### 4 Wellness & Comfort

- Advanced continuous heating
- Four steps of capacity control

### 5 Toughness

- Cooling use in high ambient temperature
- Strengthened resistance against corrosion & frost
- Long life and efficiency for the system

### 6 Serviceability

- Easy access to replacement parts

**New**  
Medium Capacity  
Model



**New**  
Large Capacity  
Model

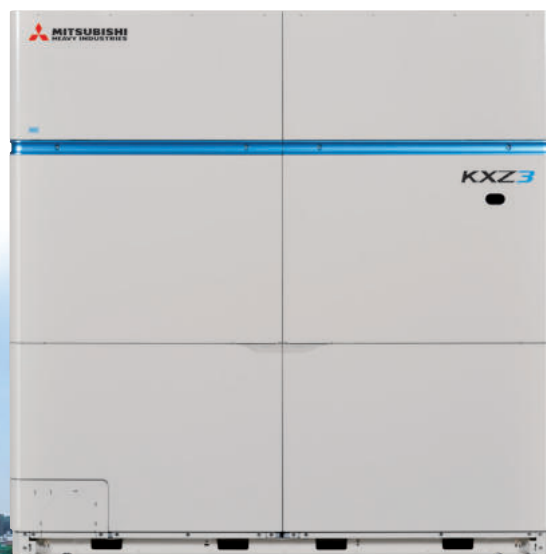

Small Capacity  
Model



Harmonize with the earth

Concept 1

# Global Environment



Meet our new **R32 KXZ3 series** of heat pumps, the perfect climate solution for heating and cooling commercial and industrial applications.

By optimizing the series with R32 refrigerant the following has increased

- Energy efficiency
- Overall performance
- Cost effectiveness
- Reduction in environmental impact



## A Low GWP Refrigerant

The Decision by MHI to transition to a new refrigerant is driven by many factors. KXZ3 with the use of R32 refrigerant, lower GWP (675) than R410A (2088)

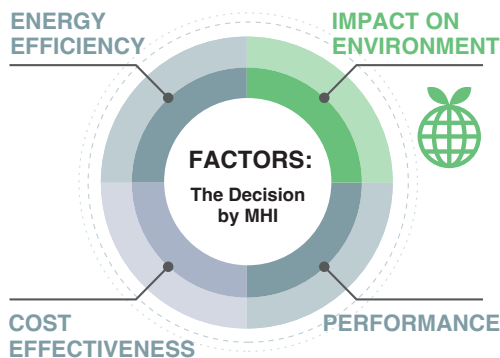

1. A single component, easy to handle refrigerant
2. Known as a component of the blend R410A (50% R32, 50% R125)
3. Already used in Air-Conditioning systems worldwide
4. Zero Ozone Depletion
5. Superior Energy Efficiency vs. R410A
6. Reduced refrigerant charge vs. R410A
7. Easy to recycle

Harmonize with buildings

Concept 2

# Wide Design Flexibility

New exterior design to fit the scenery

## 1. Unobtrusive while a refined image

The **KXZ3** blends seamlessly into modern city architecture and various environments. The exterior has been engineered with consideration for various installation settings. It remains unobtrusive while providing a refined image to its surroundings.

Rounded corners make it slim and light. The blue line and fin guard's grid shape create a strong consistent image.

The front panel's flat, trenchless surface with screws in the blue ornamentation provides a smooth texture.

The design reflects these improvements. Distinctive features such as the blue line and the fin grid convey a clear but unobtrusive message, whether as a stand-alone unit or in a combined installation.

The design allows for seamless integration into various building environments in the society.

### Rounded corners

Giving a slim and light image



### Smooth front panel with a flat surface

Giving the unit a refined image while maintaining strong structural integrity

Small Capacity Model



## A'DESIGN AWARD 2025

The KXZ3 Series has been honored with the prestigious Platinum A'DESIGN AWARD 2025 in the Industrial Design Category, the highest distinction awarded by A'DESIGN AWARD, representing a first-place recognition among thousands of global entries for its exceptional design excellence and innovation.

The KXZ3 has a impactful exterior while remaining unobtrusive providing a refined image to its surroundings. The unit has a unique exterior however when installed the unit blends in and provides the refined image to the installed buildings.



**In combination use**

**Blue ornamentation and a grid-shaped fin guard**

Gives the unit a striking yet sophisticated appearance, while enhancing its cohesive image when installed in combination



**Parallel and Diagonal Fin Guard**

The parallel and diagonal grid-shaped design also adds both visual impact and harmony to the overall aesthetic, contributing to a sleek and refined look for the buildings.

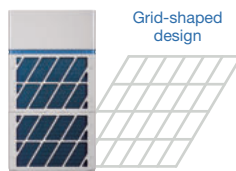

**Continuous Horizontal Blue Line**

When installed in combination, the blue ornamentation forms a continuous horizontal blue line, enhancing the unit's cohesive appearance.



## 2. Outdoor units - Product line-up -

Our line-up and limitation of use make it possible to adopt wider range of installation on commercial buildings.

### Compact design

One of the smallest in the industry

The **KXZ3 series** has reduced the installation space with the integral structure of the heat exchanger and the mechanical components.

The total footprint has become more compact compared to our previous model.

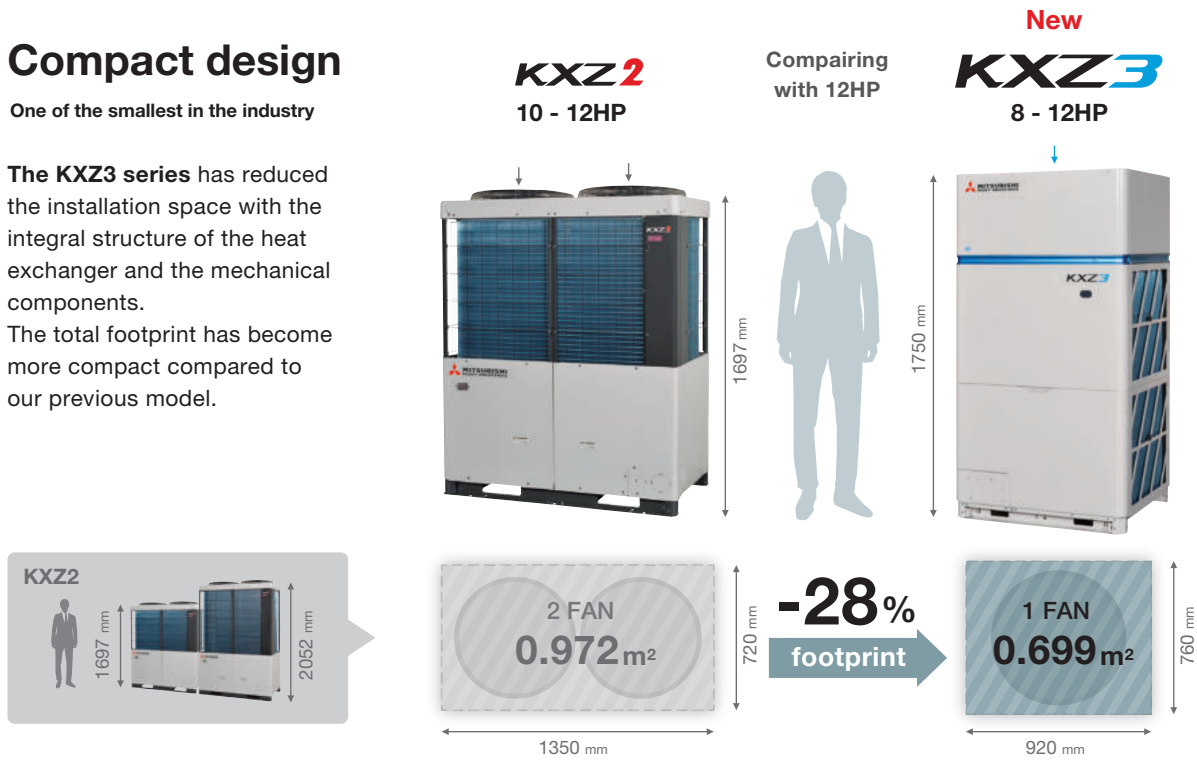

### Footprint has become more compact (compared to previous model)

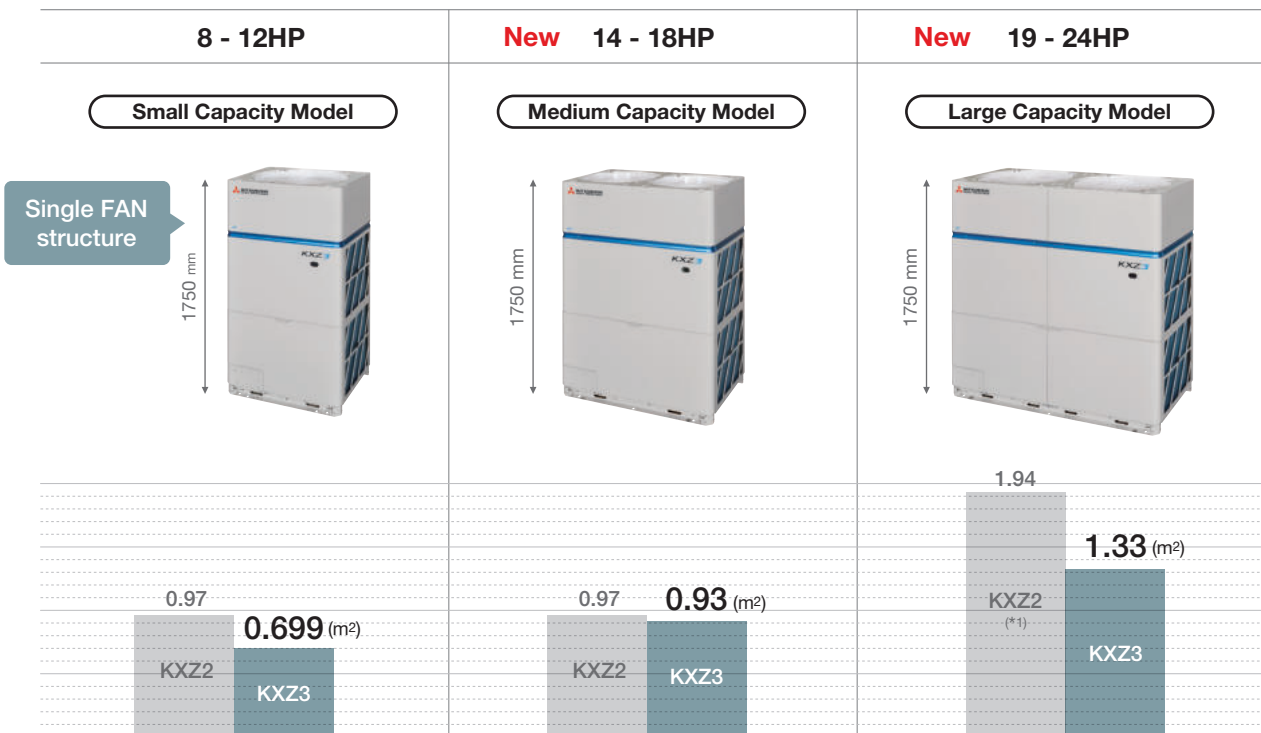

(\*1) Compared with FDC335KXZE2 × 2

# Compact or Hi-cop combination

A design that ensures uniformity and harmony when installed in combination

**(S + M)**  
Compact combination 26 HP

**(M x 2)**  
Compact combination 34 HP

**(S x 3)**  
Hi-cop combination 34 HP

**(M x 3)**  
Hi-cop combination 42 HP

**(L x 2)**  
Compact combination 48 HP

**(M x 3)**  
Hi-cop combination 48 HP

  : Compact combination  
  : Hi-cop combination

S : Small Capacity Model  
M : Medium Capacity Model  
L : Large Capacity Model

All of the unit's height  
**1750** mm

An exterior unit design that allows for cohesive installation and versatile combinations.

# Expand to 72HP

The new product line-up of our KXZ3 series has been extended to offer solutions delivering up to 72HP when using a combination of 3 outdoor units.

Single Module	Previous Model 10 - 20HP	KXZ3 <b>8 - 24HP</b>
Combination	Previous Model up to 60HP	KXZ3 <b>up to 72HP</b>

# up to 72HP

By combining 3 outdoor units 72HP can be achieved.





Various types of indoor units available

### 3. Indoor units - Product line-up -

Wide variety of  
15 types 82 models



For <b>KXZ3</b>			Capacity : HP	0.5	0.8	1	1.25	1.6	2	2.5	3.2	4	5	6	8	10
			Model Code : kW	1.5	2.2	2.8	3.6	4.5	5.6	7.1	9.0	11.2	14.0	16.0	22.4	28.0
Ceiling Cassette	4way	FDT				●	●	●	●	●	●	●	●	●		
	4way Compact	FDTC		●	●	●	●	●	●							
	2way	FDTW				●		●	●	●	●	●	●			
	1way	FDTS						●		●						
	1way Compact	FDTQ			●	●	●									
Duct Connected	High Static Pressure	FDU						●	●	●	●	●	●	●	●	●
	Low/Middle Static Pressure	FDUM			●	●	●	●	●	●	●	●	●	●		
	Low Static Pressure (thin)	FDUT		●	●	●	●	●	●	●						
	Compact & Flexible	FDUH			●	●	●									
Wall mounted	FDK		●	●	●	●	●	●	●	●	●					
Ceiling Suspended	FDE					●	●	●	●		●	●				
Floor Standing	2way	FDW				●		●	●							
	With Casing	FDL								●						
	Without Casing	FDU				●		●	●	●						
OA Processing Unit	FDU-F										●		●		●	●

## Connectability

KXZ3 - Standard Connectable Indoor Units



Increased number of connectable units and max capacity connection.

Standard KXZE3	HP	8	10	12	14	16	18	19	20	22	24	26	28 - 72
	Numbers		<b>22</b>	<b>28</b>	<b>33</b>	<b>40</b>	<b>45</b>	<b>50</b>	<b>53</b>	<b>56</b>	<b>61</b>	<b>67</b>	<b>73</b>
IU Capacity connection		<b>50 - 150%</b> (*2)											

(\*2) When connecting the indoor unit type FDK, FDFW, FDFL, FDFU series, limit the connectable capacity not higher than 130%.

### Wider limitation of piping installation

## 4. Flexible pipe installation

Total length  
**1000m**

Furthest indoor unit  
Actual length **160m**

The piping length of our KXZ series have been extended with a maximum height difference between indoor units of up to 30m enabling installation of indoor units on an extra three floors. Also, the furthest unit can be installed up to 160m from outdoor unit.

(\*1) : The difference between the longest and the shortest indoor unit piping from the first branch must be within 40m.

(\*2) : It is necessary to change the setting corresponding to each height difference in installation. The range of use is also different.

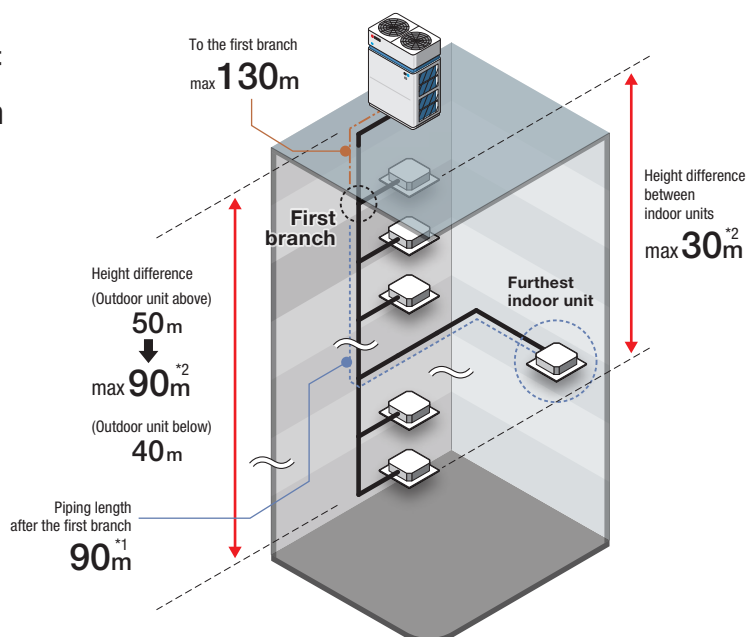

## Flexible selection of safety systems

# 4. Safety system R32 refrigerant



**R32 refrigerant** is categorized as mildly flammable (A2L) by International Standard ISO817. Safety measures specified in safety standard IEC60335-2-40 Ed.6.0. must be observed when installing or using R32 refrigerant equipment. The necessity of safety measures and the type and number of required safety equipment depend on the conditions of each room in the building.

<b>1. Refrigerant leak detector</b>	<b>2. Safety alarm</b>	<b>3. Shut-off valve</b>	<b>4. Ventilator</b> <small>MHI option has not been prepared.</small>
-------------------------------------	------------------------	--------------------------	--

The necessity of safety measures and the type and number of required safety equipment depend on the conditions of each room in the building. Safety equipment units are grouped into the following categories.

<b>Refrigerant leak detector</b> (Safety alarm)	<b>Remote Controller</b> (Safety alarm)	<b>Shut-off valve</b>
		
<b>RLD-KIT-E</b> H159 × W100 × D28 mm	<b>RC-EX3D</b> H120 × W120 × D19 mm	<b>RC-ES1</b> H86 × W86 × D17 mm
		<b>SV-KIT-S1N-E</b> <b>SV-KIT-L1N-E</b> H254 × W489 × D297 mm ( without piping )

## Example of the safety system

1. Refrigerant leak detected
2. Safety alarm is sounded, and flow of refrigerant is blocked.

- (a) : Refrigerant leak detector detects refrigerant leakage in the room.
- (b)-1 : Safety alarm sounds and light alerts to signal refrigerant leakage.
- (b)-2 : Shut-off valve in the refrigerant pipe closes and blocks the flow of refrigerant.

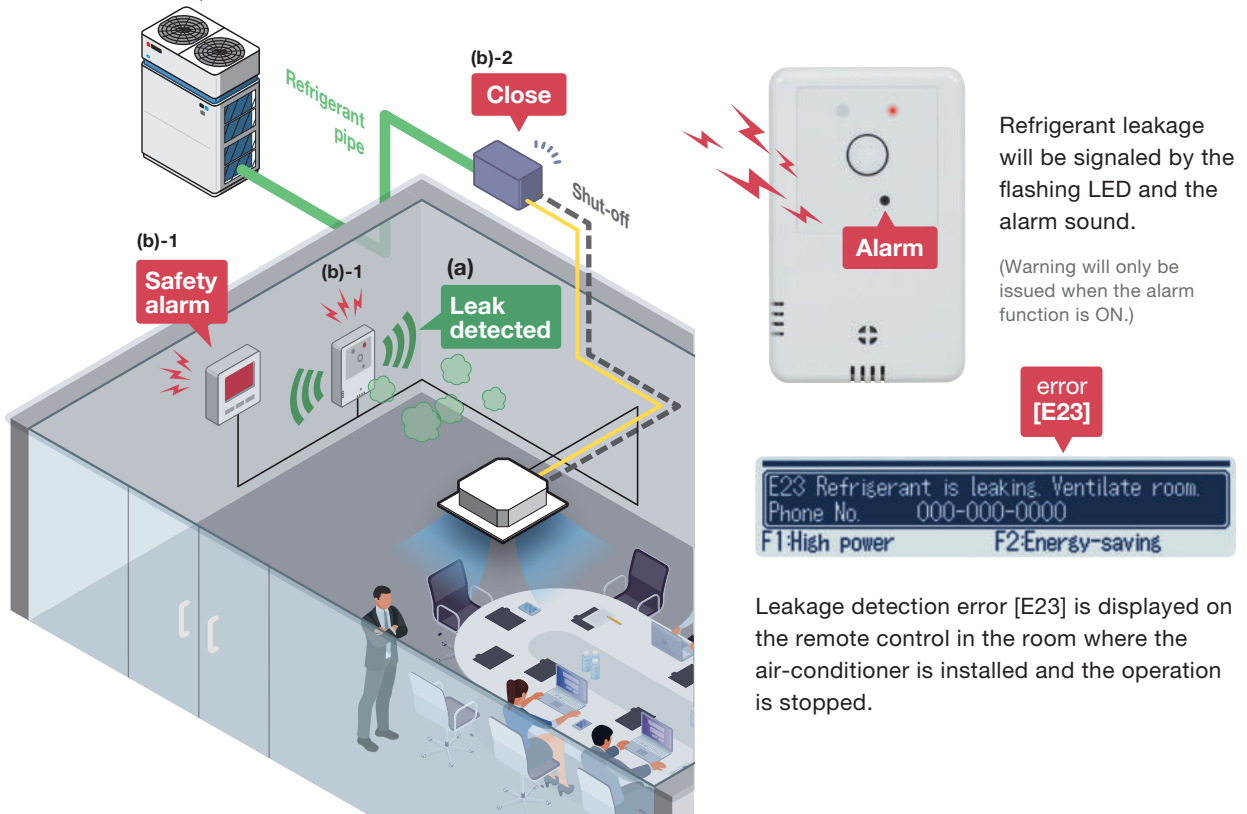

**Our safety system offers** wide flexibility of installation for safety measures. Safety system can be installed only to the rooms that are necessary.

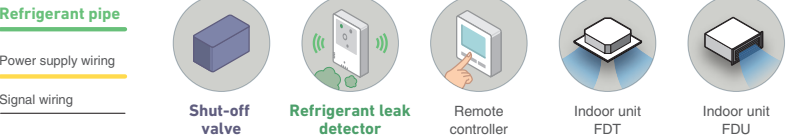

**System diagram**

One indoor unit & Multiple indoor units, one shut-off valve

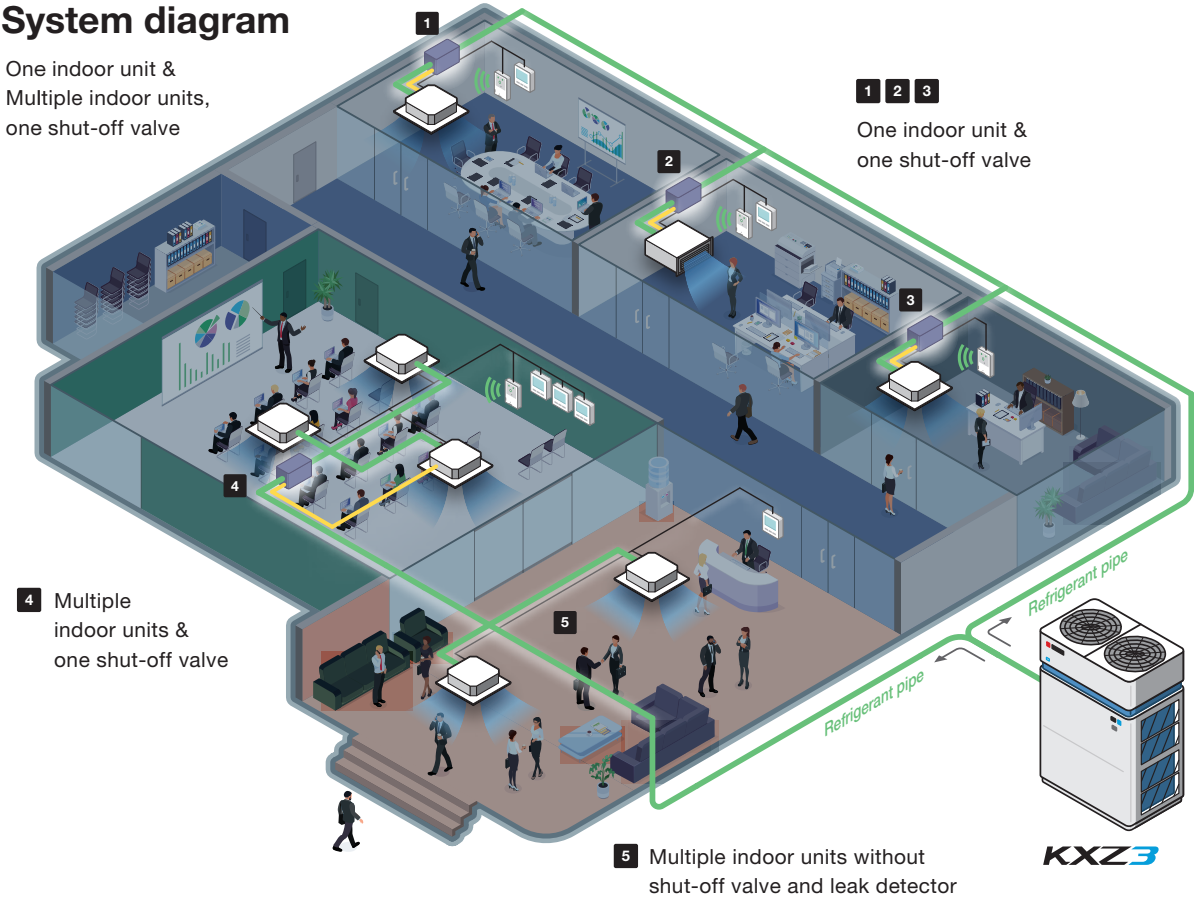

**Available for Micro KXZ / KXZ3 Series**

Refrigerant leak detector and shut-off valve may not be required depending on the room size.



Only indoor units from the KXZE3-W Series with either the RC-EX3D or RC-ES1 remote control are connectable.

**Relay Kit**

For the following models a relay kit is required to connect to the shut off valve.  
 FDUT--KXZE3-W\*    FDUH--KXZE3-W    FDFW--KXZE3-W  
 FDTQ--KXZE3-W    FDFL--KXZE3-W    FDFU--KXZE3-W  
 FDU--FKXZE3-W

\*Excluding FDUT71KXZE3-W

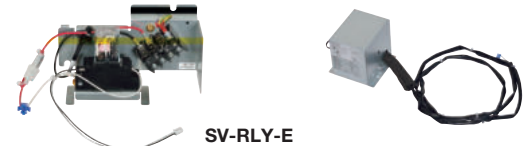

# Improved Energy Efficiency

## Higher SCOP & SEER

## Increased seasonal efficiencies

Our **KXZ3 series** provide high performance and excellent energy savings across all ranges. This is achieved by the optimized heat exchangers with the increased capacities and the advanced energy efficient compressor.

**Cooling mode** Comparison of **SEER**

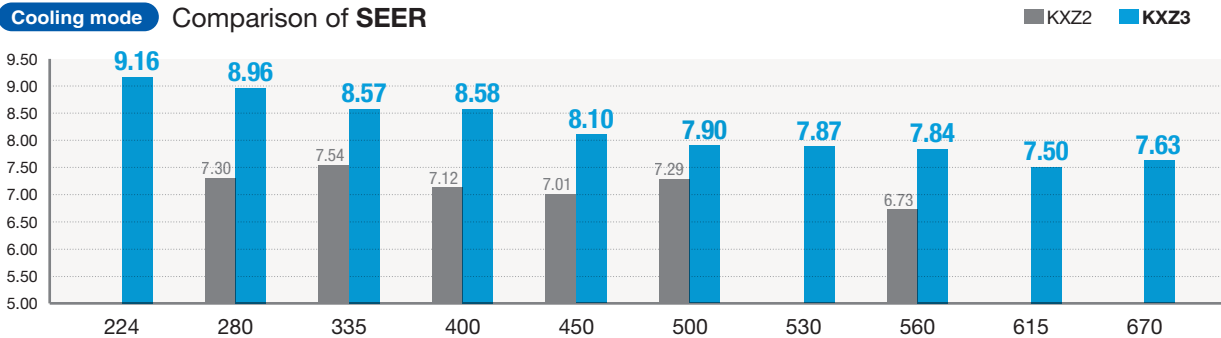

**Heating mode** Comparison of **SCOP**

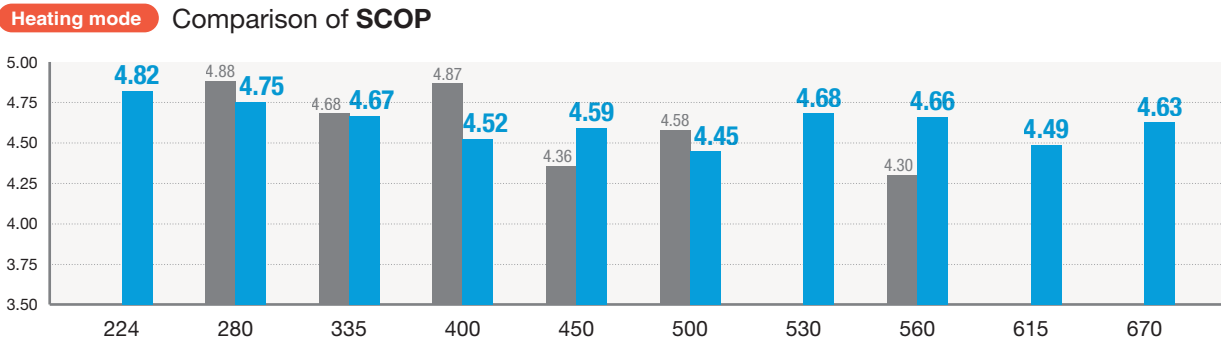

SEER/SCOP are based on EN14825:2018 and Commission regulation (EU) No.2016/2281. Temperature conditions for calculating SCOP are based on "Average climate".



## Features

Improved seasonal efficiency is achieved by

- 1** New R32 scroll compressor with the improved scroll mechanism and motor.
- 2** Heat exchanger with small copper pipe (Φ7)
- 3** Optimized fan and airflow path design
- 4** Advanced VTCC+ control



New R32 scroll compressor with the improved scroll mechanism and motor

# 1 New scroll compressor

With the adaptation of new components and its optimization, the KXZ3 series is now available in R32 refrigerant with a higher efficiency and a wide operation range. The new compressor uses the latest compressor technology and has proven to be extremely reliable.

## New Technology

1. New liquid injection structure to cool down the refrigerant

Leading to  
the wide operation range

2. Redesign of the spiral structure of the scroll

Leading to  
higher efficiency

3. Larger motor with an optimized winding structure of the coil

Leading to  
the wide operation range and improved efficiency

4. New oil circuit that returns the oil to the bottom of the compressor, decreasing the amount of discharge oil at high rotation range.

Leading to  
higher efficiency

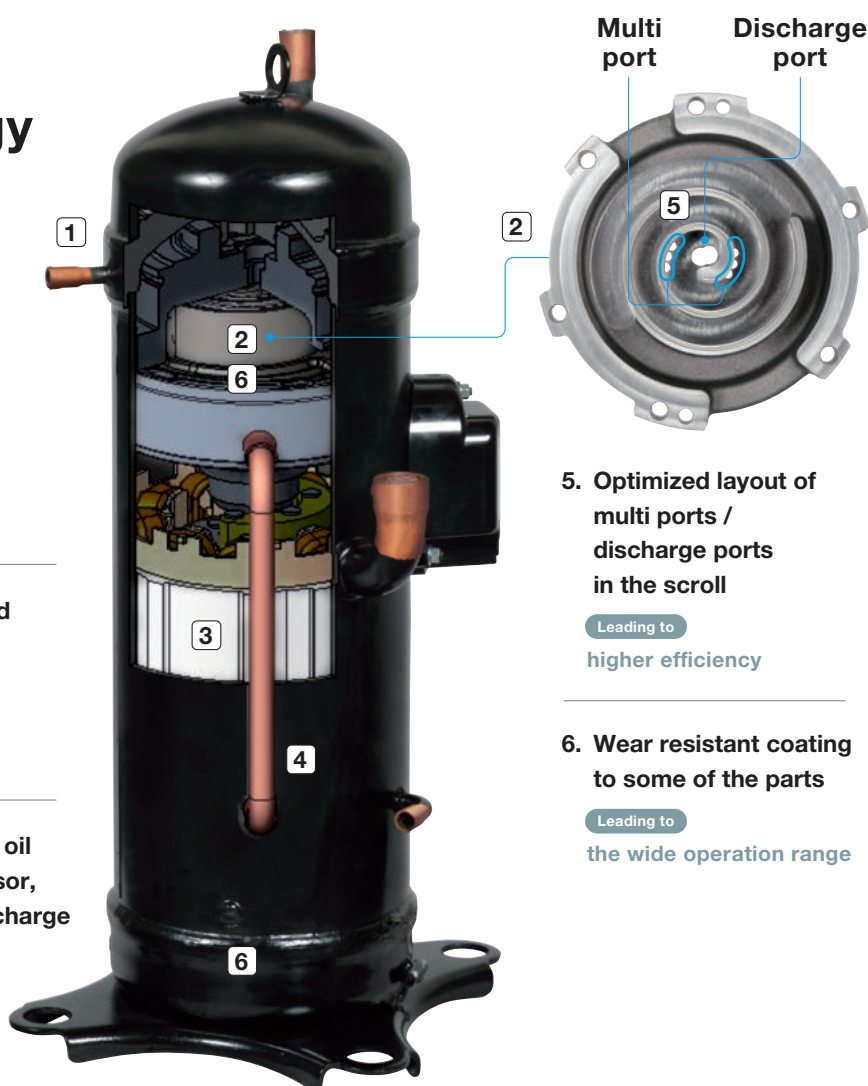

5. Optimized layout of multi ports / discharge ports in the scroll

Leading to  
higher efficiency

6. Wear resistant coating to some of the parts

Leading to  
the wide operation range

## Expansion of minimum | Rotation speed of the compressor

Achieving precise performance control

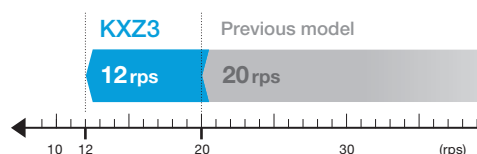

Improved energy savings and comfort at set temperature

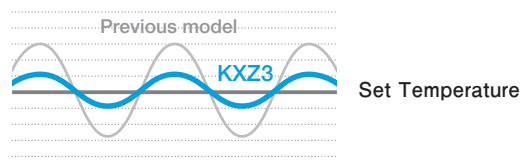

## Heat exchanger with small heat transfer pipe ( $\Phi 7.0$ )

### 2 Improved heat exchanger

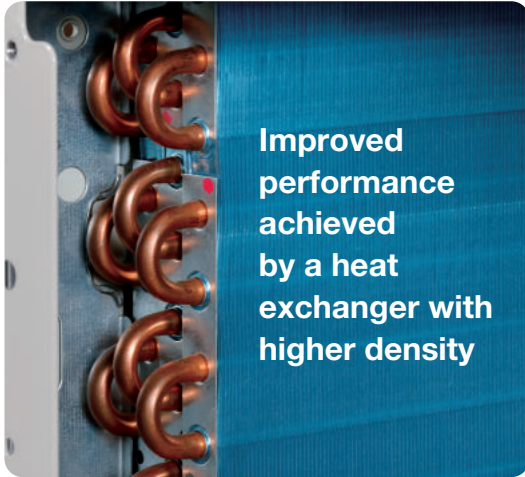

Adopting a slimmer 7.0mm copper pipe. By increasing the number of the copper pipe and fin, the performance level has improved while keeping the heat exchanger size small.

The adoption of the new slim heat exchanger has resulted in a more compact size and reduced refrigerant volume, while maintaining higher overall performance and efficiency compared to the previous model.



#### Slimmer heat exchanger and a dense copper piping

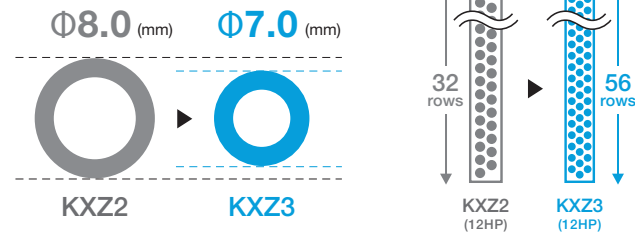

#### Optimized fan and flow path design

### 3 Optimized air flow structure

Pressure loss in air flow path is minimized with the newly designed impeller and optimized path, dedicating better energy efficiency. Regulated air flow by optimized flow path leads to more efficient heat exchange.

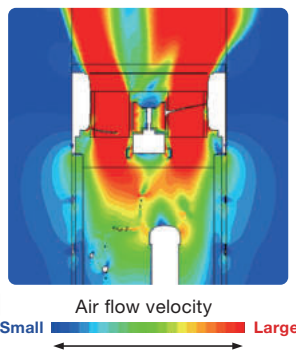
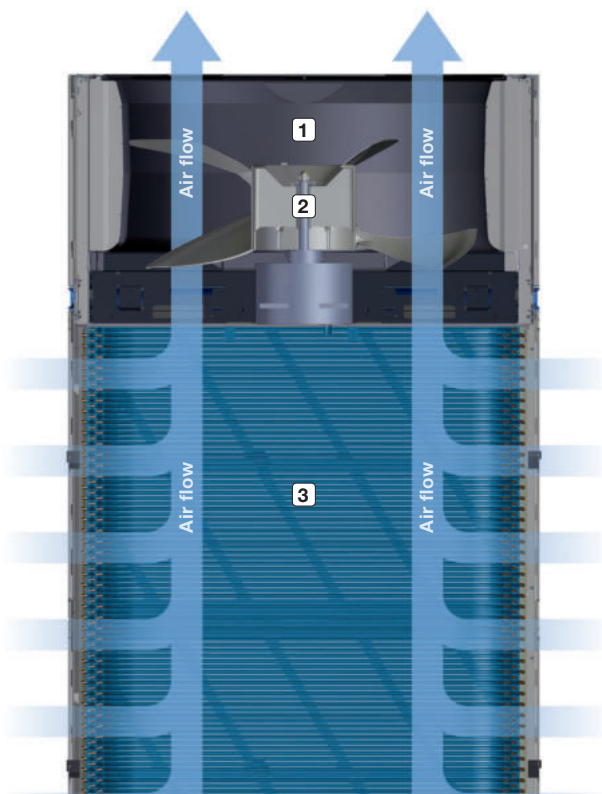

1. Optimized diffuser
2. Newly designed impeller
3. Heat exchanger

#### Extended external static pressure

Max: **90 Pa**

Flexibility to meet installation location needs.

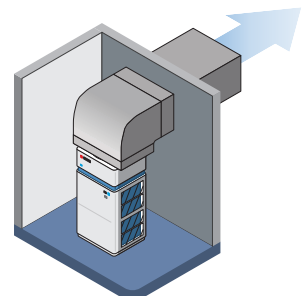

VTCC+ : advanced variable temperature and capacity control

## 4 KX VRF redesigned with VTCC+

### New Variable Temperature and Capacity Control

**VTCC+**

New VRF control VTCC+ adjusts the target pressure of the refrigerant automatically according to the requirement load of the indoor rooms in partial load conditions.

These smooth adjustments ensure an optimal capacity usage of the indoor units as well as maximised energy savings. Ultimately this also increases comfort for the user.

- Most balanced mode between capacity control and energy saving
- Target pressure is automatically adjusted according to heating/cooling requirement, which achieves energy saving
- Advanced capacity control achieves smooth temperature control close to set temperature
- Suitable for heating/cooling demand varies among the room in the building

### VTCC+ concept image

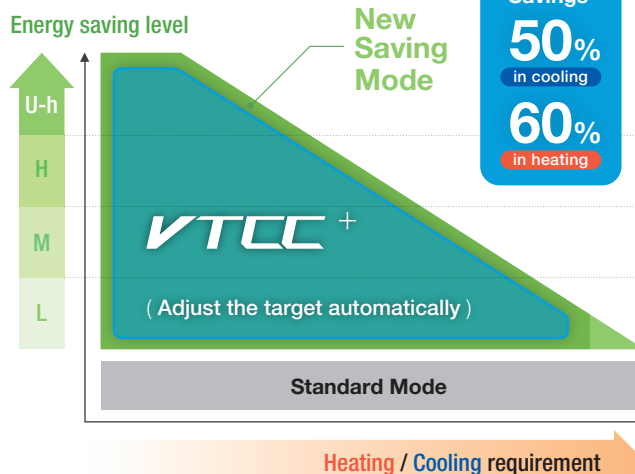

\* Saving mode(U-High) compared to standard mode in the following conditions  
 Cooling : Outside temperature 20°CDB, Partial load factor 21%, Set temperature 27°C  
 Heating : Outside temperature 12°CDB/11°CWB, Partial load factor 15%, Set temperature 20°C

### New Saving mode

- Suitable for the building with strict energy target
- Target pressure would be fixed based on the selected eco level ( Low / Medium / High / U-high )

### Standard mode

- Capacity is maximised
- Suitable for high heating/cooling demand in the building
- Target pressure is adjusted steady to maximize the capacity

### Better partial load performance

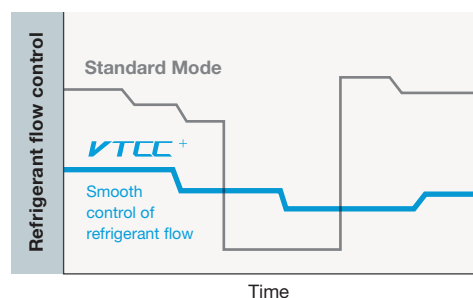
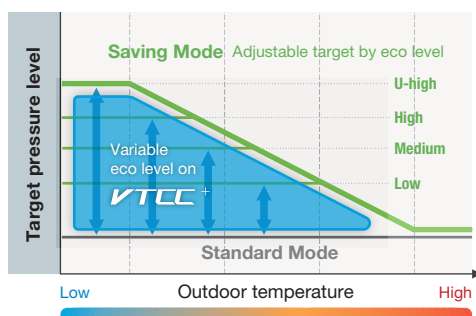
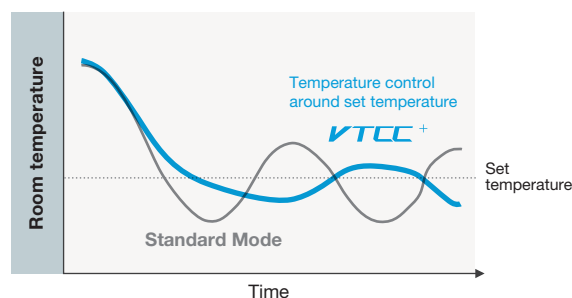
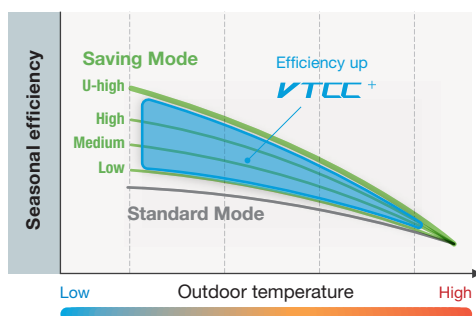
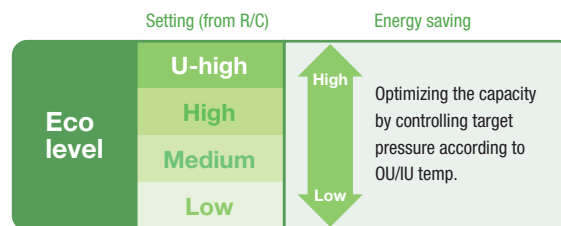

\* All the graph above shows the conditions in cooling

# Wellness & Comfort

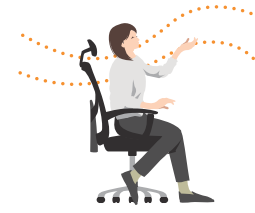

Advanced continuous heating

## Continuous heating with two defrost modes

**Two defrost modes** are prepared, and the defrost is automatically switched according to the amount of frost formation. Hot gas defrost mode enables non-stop heating during defrost operation with of hot gas bypass.

Enhanced heating operation functions

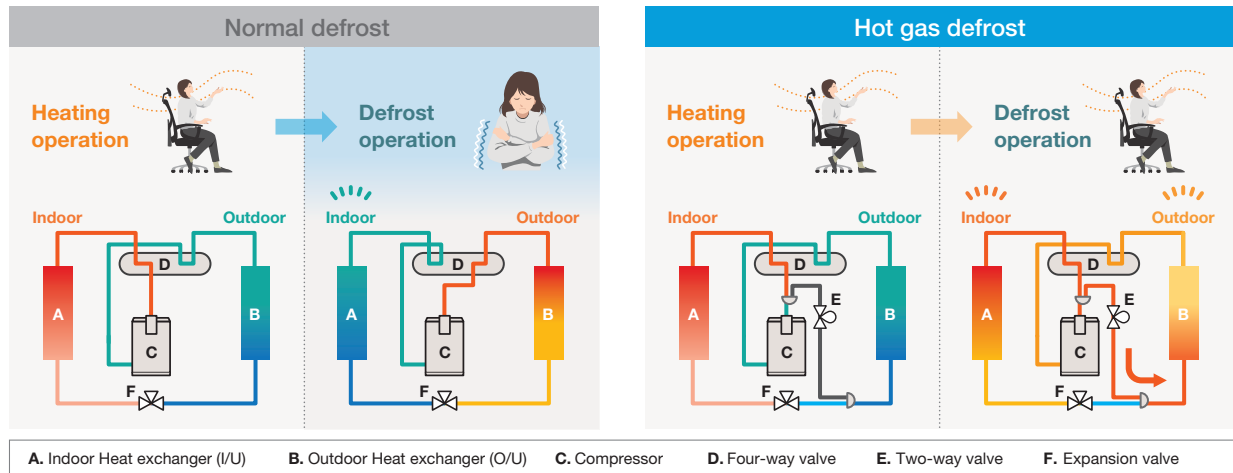

The comparison between the air outlet temperature of normal defrost and hot gas defrost

- Reduction in the time period of temperature drop caused by defrost
- Mitigation in temperature drop caused by defrost

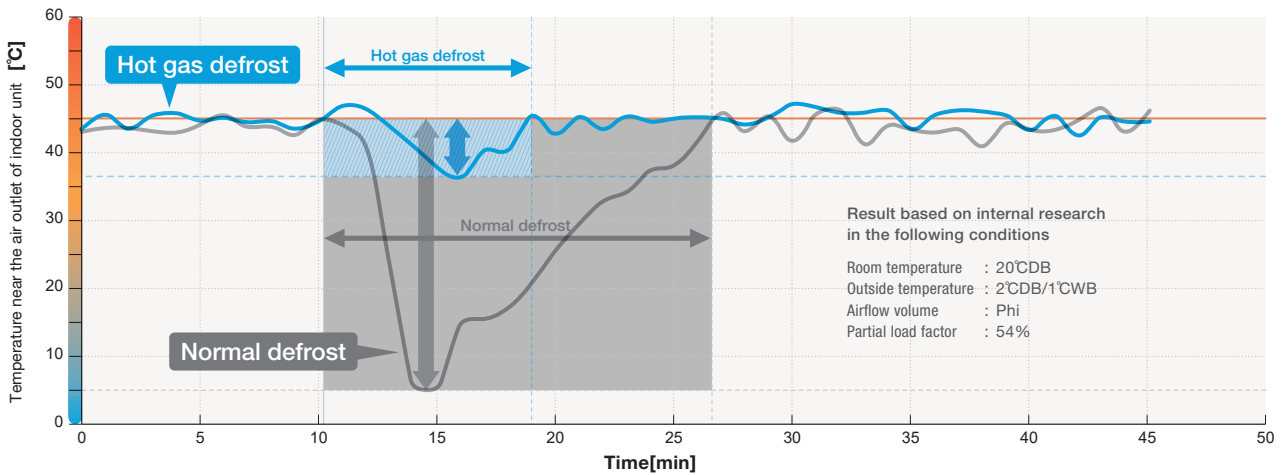

Four steps of capacity control

## Capacity control with 80%, 60%, 40%, 0% (off)

The **peak cut function** can easily be set on the controller. This function makes the control of the capacity easier and allow a better energy management over the long term. Four steps of capacity control are available with 80%, 60%, 40%, 0% (off). Schedule can be set up to 4 operations/day.

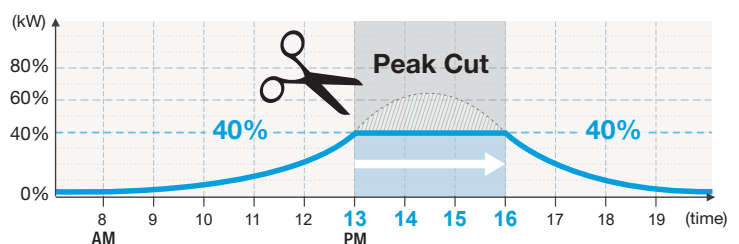

Concept 5

# Toughness

Cooling use in high ambient temperature

## Wide range of operation

Our new advanced technology has expanded the heating and cooling operation range.

KXZ3 series permits an extensible system design with a heating range operation down to  $-25^{\circ}\text{C}$  and a cooling range operation up to  $52^{\circ}\text{C}$ .



\* With limitation to piping length and height difference between indoor and outdoor units.

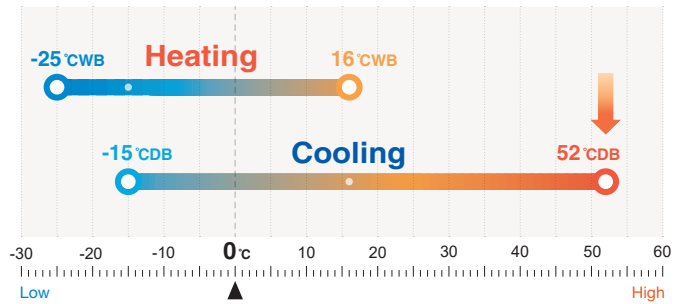

Strengthened resistance against corrosion & frost

## Blue fin

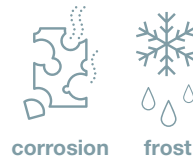

Due to application of blue coated fins on the heat exchanger of the new outdoor unit, corrosion resistance has been improved compared to previous models. Resistance against frost has been strengthened by adopting the energy efficient heat-exchanger.



Long life and efficiency for the system

## Oil level control capability

Our proprietary technology adjusts the oil level when combining two or three outdoor units, achieving level operation rate, keeping performance of the units and ensuring long life of the system.

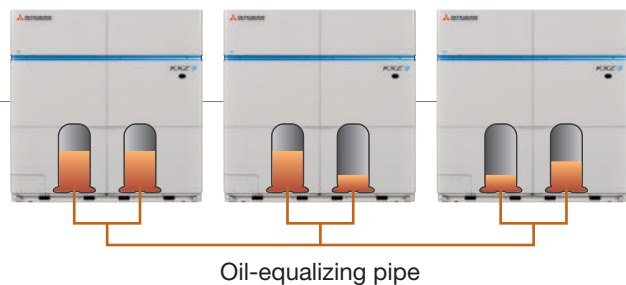

# Serviceability

Easy access to replacement parts

## Easy access to the control box

The control box is in the upper part of the unit and can now be easily accessed by taking off the upper front panel.



### Features

- The total amount of data that can be checked from the remote controller has increased
- Can save the data of the operating conditions 30–180 minutes before malfunction after the power is off (To save data for more than 30 minutes settings must be changed)
- Can now record the running hours of the fan motor

Automatically produced test-run report

Operation data storage during servicing

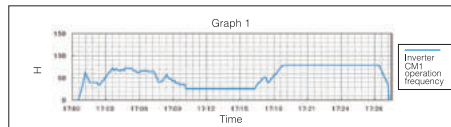

Operation data storage when a fault occurs

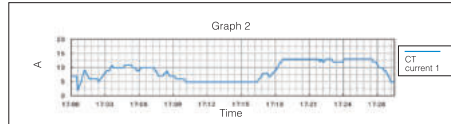

### Check Operation

Closing of Service valve, crossing connection of refrigerant piping and electrical wiring, proper operation of EEV (Electrical Expansion Valve) can be checked automatically in cooling operation. It takes 15–30 minutes and avoids frequent failure by preventing careless mistakes during installation.

### Monitoring Function

All series include features to assist with servicing and troubleshooting. Various data can be monitored through 3 or 6-digit display on the outdoor unit PCB.

Detailed fault diagnosis and operation history memory via 7-segment display.

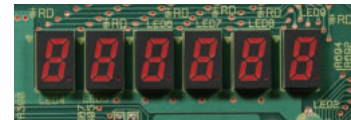

## SL Checker 2

Remote Control can be operated function from setting Superlink checker.

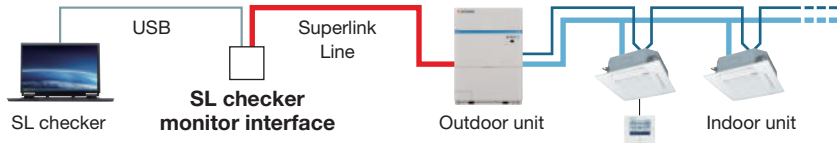

## Back-up Operation

In the event that one unit has a failure, the system will keep operating with the other units.

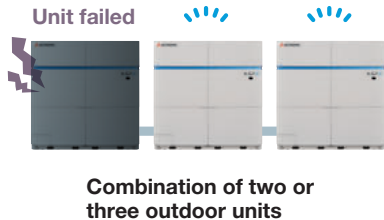

For the event that one compressor has a failure, the unit will keep operating with the other second compressor.

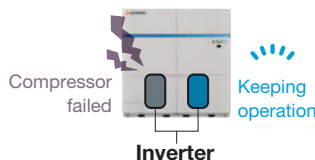

This operation is an emergency measure for a limited time and a necessary repair should be done as soon as possible.

## Energy efficient and environmentally conscious

Several radical design changes and engineering developments have brought about a vast improvement in energy efficiency and environmental protection.

### SEER and SCOP is defined in European regulations listed below.

No.2016/2281: requirement for air-heating products, cooling products, high temperature process chillers and fan coil units. Seasonal efficiency is the new way of rating the true efficiency of heating and cooling products over an entire year. Set by the EU's new regulation implementing Eco-Design Directive for Energy related Product (ErP) which specifies the minimum efficiency of air-conditioners manufacturers must integrate into their products. The new Seasonal Efficiency rating system that must be used for heating and cooling by all manufacturers are;

---

#### **SEER** - Seasonal Efficiency Ratio (value in cooling)

This ratio represents the annual cooling performance divided by the annual consumption of electricity for cooling.

#### **SCOP** - Seasonal Coefficient of Performance (value in heating)

This ratio is calculated as the divided reference annual heating performance by the annual consumption of electricity for heating.

---

#### **RoHS** - Restriction of Hazardous substances

In order to avoid the release of hazardous substances into the environment, all models have utilized lead-free solder application. It has been considered to be difficult to use lead-free solder for practical applications because it requires higher solder temperatures at assembly, which can jeopardize reliability. However our PbF soldering method can produce a higher quality lead-free printed circuit board.



# 8-12HP (22.4kW – 33.5kW)



## Technical focus

- Available in the R32 refrigerant
- New exterior design containing cutting edge technology
- High SEER with advanced technology
- VTCC<sup>+</sup> : advanced variable temperature and capacity control
- Compact design with a small total footprint
- Advanced continuous heating



The KXZ3 Series has been honored with the prestigious Platinum A' Design Award 2025 in the Industrial Design Category, the highest distinction awarded by A' Design Award, representing a first-place recognition among thousands of global entries for its exceptional design excellence and innovation.



FDC224-335

## ■ SPECIFICATIONS

Item		Model	FDC224KXZE3A	FDC280KXZE3A	FDC335KXZE3A
Nominal horse power			8	10	12
Power source			3 Phase 380-415V, 50Hz		
Nominal capacity	Cooling	kW	22.4	28.0	33.5
	Heating	kW	22.4	28.0	33.5
Max heating capacity		kW	25.0	31.5	37.5
Power consumption	Cooling	kW	5.52	8.05	9.69
	Heating	kW	4.58	6.35	7.98
EER			4.06	3.48	3.46
COP			4.90	4.41	4.20
SEER			9.16	8.96	8.57
SCOP			4.82	4.75	4.67
Exterior dimensions (HxWxD)		mm	1750 x 920 x 760		
Net weight		kg	262		
Sound power level	Cooling	dB(A)	76.0	77.0	82.0
	Heating	dB(A)	78.0	83.0	86.0
Sound pressure level	Cooling	dB(A)	55.0	56.0	60.0
	Heating	dB(A)	55.0	60.0	63.0
Starting current		A	5		
Max current		A	20.7	23.2	25.7
Refrigerant	Type / GWP		R32 / 675		
	Charge	kg	7.1		
	TCO <sub>2</sub> Eq		4.793		
Refrigerant piping size	Liquid	mm	ø9.52 (3/8")		
	Gas	(in)	ø19.05 (3/4")		
Total piping length		m	1000		
Outdoor operating temperature range	Cooling	°CDB	-15 to 52		
	Heating	°CWB	-25 to 16		
Capacity connection		%	50-150		
Number of connectable indoor units			1 to 22	1 to 28	1 to 33

1. The data are measured under the following conditions (ISO-T1, H1). Cooling: Indoor temp. of 27°CDB, 19°CWB, and outdoor temp. of 35°CDB. Heating: Indoor temp. of 20°CDB, and outdoor temp. of 7°CDB, 6°CWB.  
 2. SEER/SCOP are based on EN14825:2018 and Commission regulation (EU) No.2016/2281. Temperature conditions for calculating SCOP are based on "Average climate".  
 3. Sound level indicates the value in an anechoic chamber. During operation these values are somewhat higher due to ambient conditions.  
 4. 'tonne(s) of CO<sub>2</sub> equivalent' means a quantity of greenhouse gases- expressed as the product of the weight of the greenhouse gases in metric tonnes and of their global warming potential.  
 5. When connecting the indoor unit type FDK, FDFL, FDFU or FDFW series, limit the connectable capacity not higher than 130%.

# 14-18HP (40.0kW – 50.0kW)



## Technical focus

- Available in the R32 refrigerant
- New exterior design containing cutting edge technology
- High SEER with advanced technology
- VTCC+ : advanced variable temperature and capacity control
- Advanced continuous heating

**New**



FDC400-500

## ■ SPECIFICATIONS

Item		Model	FDC400KXZE3	FDC450KXZE3	FDC500KXZE3
Nominal horse power			14	16	18
Power source			3 Phase 380-415V, 50Hz		
Nominal capacity	Cooling	kW	40.0	45.0	50.0
	Heating		40.0	45.0	47.5
Max heating capacity		kW	45.0	50.0	56.0
Power consumption	Cooling	kW	11.73	14.88	17.70
	Heating		8.42	10.14	10.86
EER			3.41	3.02	2.82
COP			4.75	4.43	4.37
SEER			8.58	8.10	7.90
SCOP			4.52	4.59	4.45
Exterior dimensions (HxWxD)		mm	1750 x 1220 x 760		
Net weight		kg	352		
Sound power level	Cooling	dB(A)	79.0	82.0	84.5
	Heating		84.5	89.0	90.0
Sound pressure level	Cooling	dB(A)	56.0	59.0	61.5
	Heating		61.5	66.0	67.0
Starting current		A	5		
Max current		A	32.4	36.3	40.5
Refrigerant	Type / GWP		R32 / 675		
	Charge	kg	8.7		
	TCO <sub>2</sub> Eq		5.873		
Refrigerant piping size	Liquid	mm	ø12.7 (1/2")		
	Gas	(in)	ø28.58 (1-1/8")		
Total piping length		m	1000		
Outdoor operating temperature range	Cooling	°CDB	-15 to 52		
	Heating	°CWB	-25 to 16		
Capacity connection		%	50-150		
Number of connectable indoor units			1 to 40	1 to 45	1 to 50

1. The data are measured under the following conditions (ISO-T1, H1). Cooling: Indoor temp. of 27°CDB, 19°CWB, and outdoor temp. of 35°CDB. Heating: Indoor temp. of 20°CDB, and outdoor temp. of 7°CDB, 6°CWB.  
 2. SEER/SCOP are based on EN14825:2018 and Commission regulation (EU) No.2016/2281. Temperature conditions for calculating SCOP are based on "Average climate".  
 3. Sound level indicates the value in an anechoic chamber. During operation these values are somewhat higher due to ambient conditions.  
 4. "tonne(s) of CO<sub>2</sub> equivalent" means a quantity of greenhouse gases- expressed as the product of the weight of the greenhouse gases in metric tonnes and of their global warming potential.  
 5. When connecting the indoor unit type FDK, FDFL, FDFU or FDFW series, limit the connectable capacity not higher than 130%.

# 19-24HP (53.0kW – 67.0kW)



## Technical focus

- Available in the R32 refrigerant
- New exterior design containing cutting edge technology
- High SEER with advanced technology
- VTCC+ : advanced variable temperature and capacity control
- Advanced continuous heating

**New**



FDC530-670

## ■ SPECIFICATIONS

Item	Model	FDC530KXZE3	FDC560KXZE3	FDC615KXZE3	FDC670KXZE3
Nominal horse power		19	20	22	24
Power source		3 Phase 380-415V, 50Hz			
Nominal capacity	Cooling	53.0	56.0	61.5	67.0
	Heating	53.0	56.0	61.5	65.0
Max heating capacity	kW	59.0	61.5	69.0	75.0
Power consumption	Cooling	15.20	16.20	18.77	24.39
	Heating	11.05	12.34	15.01	15.77
EER		3.48	3.45	3.27	2.74
COP		4.79	4.53	4.09	4.12
SEER		7.87	7.84	7.50	7.63
SCOP		4.68	4.66	4.49	4.63
Exterior dimensions (HxWxD)	mm	1750 x 1750 x 760			
Net weight	kg	445			
Sound power level	Cooling	81.5	82.0	85.0	85.5
	Heating	86.0	86.5	90.0	90.0
Sound pressure level	Cooling	59.0	59.5	62.5	63.0
	Heating	63.5	64.0	67.5	67.5
Starting current	A	8			
Max current	A	47.4	50.6	52.2	55.4
Refrigerant	Type / GWP	R32 / 675			
	Charge	9.5			
	TCO <sub>2</sub> Eq	6.413			
Refrigerant piping size	Liquid	ø12.7 (1/2")			
	Gas	ø28.58 (1-1/8")			
Total piping length	m	1000			
Outdoor operating temperature range	Cooling	-15 to 52			
	Heating	-25 to 16			
Capacity connection	%	50-150			
Number of connectable indoor units		1 to 53	1 to 56	2 to 61	2 to 67

1. The data are measured under the following conditions (ISO-T1, H1). Cooling: Indoor temp. of 27°CDB, 19°CWB, and outdoor temp. of 35°CDB. Heating: Indoor temp. of 20°CDB, and outdoor temp. of 7°CDB, 6°CWB.  
 2. SEER/SCOP are based on EN14825:2018 and Commission regulation (EU) No.2016/2281. Temperature conditions for calculating SCOP are based on "Average climate".  
 3. Sound level indicates the value in an anechoic chamber. During operation these values are somewhat higher due to ambient conditions.  
 4. 'tonne(s) of CO<sub>2</sub> equivalent' means a quantity of greenhouse gases- expressed as the product of the weight of the greenhouse gases in metric tonnes and of their global warming potential.  
 5. When connecting the indoor unit type FDK, FDFL, FDFU or FDFW series, limit the connectable capacity not higher than 130%.

## 26-36 HP (73.5kW – 100.0kW)



### Technical focus

- Available in the R32 refrigerant
- New exterior design containing cutting edge technology
- High SEER with advanced technology
- VTCC+ : advanced variable temperature and capacity control
- Advanced continuous heating

**New**



FDC735



FDC800-1000

### SPECIFICATIONS

Item	Model	FDC735KXZE3	FDC800KXZE3	FDC850KXZE3	FDC900KXZE3	FDC950KXZE3	FDC1000KXZE3
Combination		FDC335KXZE3A	FDC400KXZE3	FDC400KXZE3	FDC450KXZE3	FDC450KXZE3	FDC500KXZE3
		FDC400KXZE3	FDC400KXZE3	FDC450KXZE3	FDC450KXZE3	FDC500KXZE3	FDC500KXZE3
Nominal horse power		26	28	30	32	34	36
Power source		3 Phase 380-415V, 50Hz					
Nominal capacity	Cooling	73.5	80.0	85.0	90.0	95.0	100.0
	Heating	73.5	80.0	85.0	90.0	92.5	95.0
Max heating capacity	kW	82.5	90.0	95.0	100.0	106.0	112.0
Power consumption	Cooling	21.4	23.5	26.6	29.8	32.6	35.5
	Heating	16.4	17.7	19.3	20.8	21.0	21.7
EER		3.43	3.41	3.19	3.02	2.91	2.82
COP		4.48	4.51	4.40	4.32	4.39	4.37
SEER		8.57	8.58	8.34	8.10	8.00	7.90
SCOP		4.59	4.52	4.55	4.59	4.52	4.45
Net weight	kg	626			704		
Max current	A	58.1	64.8	68.7	72.6	76.8	81.0
Refrigerant piping size	Liquid	ø15.88 (5/8")					
	Gas	ø34.92 (1-3/8")					
	Oil equalization	ø12.7 (1/2")					
Total piping length	m	1000					
Outdoor operating temperature range	Cooling	°CDB					
	Heating	°CWB					
Capacity connection	%	50-150					
Number of connectable indoor units		2 to 73			2 to 80		

1. The data are measured under the following conditions (ISO-T1, H1). Cooling: Indoor temp. of 27°CDB, 19°CWB, and outdoor temp. of 35°CDB. Heating: Indoor temp. of 20°CDB, and outdoor temp. of 7°CDB, 6°CWB.  
 2. SEER/SCOP are based on EN14825:2018 and Commission regulation (EU) No.2016/2281. Temperature conditions for calculating SCOP are based on "Average climate".  
 3. Sound level indicates the value in an anechoic chamber. During operation these values are somewhat higher due to ambient conditions.  
 4. 'tonne(s) of CO<sub>2</sub> equivalent' means a quantity of greenhouse gases- expressed as the product of the weight of the greenhouse gases in metric tonnes and of their global warming potential.  
 5. When connecting the indoor unit type FDK, FDFL, FDFU or FDFW series, limit the connectable capacity not higher than 130%.

# 38-48HP (106.0kW – 134.0kW)



## Technical focus

- Available in the R32 refrigerant
- New exterior design containing cutting edge technology
- High SCOP & SEER with advanced technology
- VTCC<sup>+</sup> : advanced variable temperature and capacity control
- Advanced continuous heating

**New**



FDC1060-1340

## SPECIFICATIONS

Item	Model	FDC1060KXZE3	FDC1120KXZE3	FDC1175KXZE3	FDC1230KXZE3	FDC1285KXZE3	FDC1340KXZE3
Combination		FDC530KXZE3	FDC560KXZE3	FDC560KXZE3	FDC615KXZE3	FDC615KXZE3	FDC670KXZE3
		FDC530KXZE3	FDC560KXZE3	FDC615KXZE3	FDC615KXZE3	FDC670KXZE3	FDC670KXZE3
Nominal horse power		38	40	42	44	46	48
Power source		3 Phase 380-415V, 50Hz					
Nominal capacity	Cooling	106.0	112.0	117.5	123.0	128.5	134.0
	Heating	106.0	112.0	117.5	123.0	126.5	130.0
Max heating capacity	kW	118.0	123.0	130.5	138.0	144.0	150.0
Power consumption	Cooling	30.5	32.5	35.0	37.6	43.3	48.9
	Heating	22.1	24.7	27.4	30.1	30.8	31.6
EER		3.48	3.45	3.35	3.27	2.97	2.74
COP		4.79	4.53	4.28	4.09	4.10	4.12
SEER		7.87	7.84	7.67	7.50	7.56	7.63
SCOP		4.62	4.57	4.52	4.49	4.56	4.59
Net weight	kg	890					
Max current	A	94.8	101.2	102.8	104.4	107.6	110.8
Refrigerant piping size	Liquid	ø19.05 (3/4")					
	Gas	ø34.92 (1-3/8")					
	Oil equalization	ø12.7 (1/2")					
Total piping length	m	1000					
Outdoor operating temperature range	Cooling	-15 to 52					
	Heating	-25 to 16					
Capacity connection	%	50-150					
Number of connectable indoor units		2 to 80			3 to 80		

1. The data are measured under the following conditions (ISO-T1, H1). Cooling: Indoor temp. of 27°CDB, 19°CWB, and outdoor temp. of 35°CDB. Heating: Indoor temp. of 20°CDB, and outdoor temp. of 7°CDB, 6°CWB.  
 2. SEER/SCOP are based on EN14825:2018 and Commission regulation (EU) No.2016/2281. Temperature conditions for calculating SCOP are based on "Average climate".  
 3. Sound level indicates the value in an anechoic chamber. During operation these values are somewhat higher due to ambient conditions.  
 4. 'tonne(s) of CO<sub>2</sub> equivalent' means a quantity of greenhouse gases- expressed as the product of the weight of the greenhouse gases in metric tonnes and of their global warming potential.  
 5. When connecting the indoor unit type FDK, FDFL, FDFU or FDFW series, limit the connectable capacity not higher than 130%.

# 50-54HP (140.0kW-150.0kW)



## Technical focus

- Available in the R32 refrigerant
- New exterior design containing cutting edge technology
- High SCOP & SEER with advanced technology
- VTCC+ : advanced variable temperature and capacity control
- Advanced continuous heating

**New**



FDC1400-1500

## SPECIFICATIONS

Item	Model	FDC1400KXZE3	FDC1450KXZE3	FDC1500KXZE3
Combination		FDC450KXZE3	FDC450KXZE3	FDC500KXZE3
		FDC450KXZE3	FDC500KXZE3	FDC500KXZE3
		FDC500KXZE3	FDC500KXZE3	FDC500KXZE3
Nominal horse power		50	52	54
Power source		3 Phase 380-415V, 50Hz		
Nominal capacity	Cooling	140.0	145.0	150.0
	Heating	137.5	140.0	142.5
Max heating capacity	kW	156.0	162.0	168.0
Power consumption	Cooling	47.5	50.4	53.2
	Heating	31.2	31.9	32.6
EER		2.94	2.87	2.82
COP		4.40	4.38	4.37
SEER		8.03	7.96	7.90
SCOP		4.54	4.49	4.45
Net weight	kg	1056		
Max current	A	113.1	117.3	121.5
Refrigerant piping size	Liquid	ø19.05 (3/4")		
	Gas	ø34.92(1-3/8")		ø41.28(1-5/8")
	Oil equalization	ø12.7 (1/2")		
Total piping length	m	1000		
Outdoor operating temperature range	Cooling	°CDB -15 to 52		
	Heating	°CWB -25 to 16		
Capacity connection	%	50-150		
Number of connectable indoor units		3 to 80		

1. The data are measured under the following conditions (ISO-T1, H1). Cooling: Indoor temp. of 27°CDB, 19°CWB, and outdoor temp. of 35°CDB. Heating: Indoor temp. of 20°CDB, and outdoor temp. of 7°CDB, 6°CWB.  
 2. SEER/SCOP are based on EN14825:2018 and Commission regulation (EU) No.2016/2281. Temperature conditions for calculating SCOP are based on "Average climate".  
 3. Sound level indicates the value in an anechoic chamber. During operation these values are somewhat higher due to ambient conditions.  
 4. 'tonne(s) of CO<sub>2</sub> equivalent' means a quantity of greenhouse gases- expressed as the product of the weight of the greenhouse gases in metric tonnes and of their global warming potential.  
 5. When connecting the indoor unit type FDK, FDFL, FDFU or FDFW series, limit the connectable capacity not higher than 130%.

# 57-60HP (159.0kW -168.0kW)



## Technical focus

- Available in the R32 refrigerant
- New exterior design containing cutting edge technology
- High SCOP & SEER with advanced technology
- VTCC+ : advanced variable temperature and capacity control
- Advanced continuous heating

**New**



FDC1560-1680

## ■ SPECIFICATIONS

Item	Model	FDC1560KXZE3	FDC1620KXZE3	FDC1680KXZE3
Combination		FDC530KXZE3	FDC530KXZE3	FDC560KXZE3
		FDC530KXZE3	FDC530KXZE3	FDC560KXZE3
		FDC530KXZE3	FDC560KXZE3	FDC560KXZE3
Nominal horse power		57	58	60
Power source		3 Phase 380-415V, 50Hz		
Nominal capacity	Cooling	159.0	162.0	168.0
	Heating			
Max heating capacity	kW	177.0	179.5	184.5
Power consumption	Cooling	33.2	34.5	37.1
	Heating			
EER		3.48	3.46	3.45
COP		4.79	4.69	4.53
SEER		7.87	7.86	7.84
SCOP		4.68	4.67	4.66
Net weight	kg	1335		
Max current	A	142.2	145.4	151.8
Refrigerant piping size	Liquid	ø19.05 (3/4")		
	Gas	ø41.28 (1-5/8")		
	Oil equalization	ø12.7 (1/2")		
Total piping length	m	1000		
Outdoor operating temperature range	Cooling	-15 to 52		
	Heating	-25 to 16		
Capacity connection	%	50-150		
Number of connectable indoor units		3 to 80		

1. The data are measured under the following conditions (ISO-T1, H1). Cooling: Indoor temp. of 27°CDB, 19°CWB, and outdoor temp. of 35°CDB. Heating: Indoor temp. of 20°CDB, and outdoor temp. of 7°CDB, 6°CWB.  
 2. SEER/SCOP are based on EN14825:2018 and Commission regulation (EU) No.2016/2281. Temperature conditions for calculating SCOP are based on "Average climate".  
 3. Sound level indicates the value in an anechoic chamber. During operation these values are somewhat higher due to ambient conditions.  
 4. 'tonne(s) of CO<sub>2</sub> equivalent' means a quantity of greenhouse gases- expressed as the product of the weight of the greenhouse gases in metric tonnes and of their global warming potential.  
 5. When connecting the indoor unit type FDK, FDFL, FDFU or FDFW series, limit the connectable capacity not higher than 130%.

# 62-72HP (173.5kW-201.0kW)



## Technical focus

- Available in the R32 refrigerant
- New exterior design containing cutting edge technology
- High SCOP & SEER with advanced technology
- VTCC+ : advanced variable temperature and capacity control
- Advanced continuous heating

**New**



FDC1735-2010

## ■ SPECIFICATIONS

Item	Model	FDC1735KXZE3	FDC1790KXZE3	FDC1845KXZE3	FDC1900KXZE3	FDC1955KXZE3	FDC2010KXZE3
Combination		FDC560KXZE3	FDC560KXZE3	FDC615KXZE3	FDC615KXZE3	FDC615KXZE3	FDC670KXZE3
		FDC560KXZE3	FDC615KXZE3	FDC615KXZE3	FDC615KXZE3	FDC670KXZE3	FDC670KXZE3
		FDC615KXZE3	FDC615KXZE3	FDC615KXZE3	FDC670KXZE3	FDC670KXZE3	FDC670KXZE3
Nominal horse power		62	64	66	68	70	72
Power source		3 Phase 380-415V, 50Hz					
Nominal capacity	Cooling	173.5	179.0	184.5	190.0	195.5	201.0
	Heating	173.5	179.0	184.5	188.0	191.5	195.0
Max heating capacity	kW	192.0	199.5	207.0	213.0	219.0	225.0
Power consumption	Cooling	51.3	53.8	56.4	62.1	67.7	73.4
	Heating	39.8	42.4	45.1	45.9	46.6	47.3
EER		3.38	3.32	3.27	3.06	2.88	2.74
COP		4.36	4.21	4.09	4.10	4.11	4.12
SEER		7.72	7.61	7.50	7.54	7.58	7.63
SCOP		4.60	4.54	4.49	4.53	4.58	4.63
Net weight	kg	1335					
Max current	A	153.4	155.0	156.6	159.8	163.0	166.2
Refrigerant piping size	Liquid	ø22.22 (7/8")					
	Gas	ø41.28 (1-5/8")					
	Oil equalization	ø12.7 (1/2")					
Total piping length	m	1000					
Outdoor operating temperature range	Cooling	°CDB -15 to 52					
	Heating	°CWB -25 to 16					
Capacity connection	%	50-150					
Number of connectable indoor units		4 to 80					

1. The data are measured under the following conditions (ISO-T1, H1). Cooling: Indoor temp. of 27°CDB, 19°CWB, and outdoor temp. of 35°CDB. Heating: Indoor temp. of 20°CDB, and outdoor temp. of 7°CDB, 6°CWB.  
 2. SEER/SCOP are based on EN14825:2018 and Commission regulation (EU) No.2016/2281. Temperature conditions for calculating SCOP are based on "Average climate".  
 3. Sound level indicates the value in an anechoic chamber. During operation these values are somewhat higher due to ambient conditions.  
 4. 'tonne(s) of CO<sub>2</sub> equivalent' means a quantity of greenhouse gases- expressed as the product of the weight of the greenhouse gases in metric tonnes and of their global warming potential.  
 5. When connecting the indoor unit type FDK, FDL, FDFU or FDFW series, limit the connectable capacity not higher than 130%.

# 16-24HP (44.8kW – 67.0kW)



## Technical focus

- Available in the R32 refrigerant
- New exterior design containing cutting edge technology
- High SCOP & SEER with advanced technology
- VTCC<sup>+</sup> : advanced variable temperature and capacity control
- Advanced continuous heating



FDC450-670

## ■ SPECIFICATIONS

Item	Model	FDC450KXZVE3	FDC500KXZVE3	FDC560KXZVE3	FDC615KXZVE3	FDC670KXZVE3
Combination		FDC224KXZE3A	FDC224KXZE3A	FDC280KXZE3A	FDC280KXZE3A	FDC335KXZE3A
		FDC224KXZE3A	FDC280KXZE3A	FDC280KXZE3A	FDC335KXZE3A	FDC335KXZE3A
Nominal horse power		16	18	20	22	24
Power source		3 Phase 380-415V, 50Hz				
Nominal capacity	Cooling	44.8	50.4	56.0	61.5	67.0
	Heating	44.8	50.4	56.0	61.5	67.0
Max heating capacity	kW	50.0	56.5	63.0	69.0	75.0
Power consumption	Cooling	11.0	13.6	16.1	17.7	19.4
	Heating	9.1	10.9	12.7	14.3	16.0
EER		4.06	3.71	3.48	3.46	3.46
COP		4.90	4.61	4.41	4.29	4.20
SEER		9.16	9.02	8.97	8.74	8.57
SCOP		4.82	4.78	4.75	4.70	4.67
Net weight	kg		524		536	548
Max current	A	41.4	43.9	46.4	48.9	51.4
Refrigerant piping size	Liquid	ø12.7 (1/2")				
	Gas	ø28.58 (1-1/8")				
	Oil equalization	ø12.7 (1/2")				
Total piping length	m	1000				
Outdoor operating temperature range	Cooling	-15 to 52				
	Heating	-25 to 16				
Capacity connection	%	50-150				
Number of connectable indoor units		1 to 45	1 to 50	1 to 56	2 to 61	2 to 67

1. The data are measured under the following conditions (ISO-T1, H1). Cooling: Indoor temp. of 27°CDB, 19°CWB, and outdoor temp. of 35°CDB. Heating: Indoor temp. of 20°CDB, and outdoor temp. of 7°CDB, 6°CWB.

2. SEER/SCOP are based on EN14825:2018 and Commission regulation (EU) No.2016/2281. Temperature conditions for calculating SCOP are based on "Average climate".

3. Sound level indicates the value in an anechoic chamber. During operation these values are somewhat higher due to ambient conditions.

4. 'tonne(s) of CO<sub>2</sub> equivalent' means a quantity of greenhouse gases- expressed as the product of the weight of the greenhouse gases in metric tonnes and of their global warming potential.

5. When connecting the indoor unit type FDK, FDFL, FDFU or FDFW series, limit the connectable capacity not higher than 130%.



**Technical focus**

- Available in the R32 refrigerant
- New exterior design containing cutting edge technology
- High SCOP & SEER with advanced technology
- VTCC+ : advanced variable temperature and capacity control
- Advanced continuous heating



FDC735-1000

**SPECIFICATIONS**

Item	Model	FDC735KXZVE3	FDC800KXZVE3	FDC850KXZVE3	FDC900KXZVE3	FDC950KXZVE3	FDC1000KXZVE3	
Combination		FDC224KXZE3A	FDC224KXZE3A	FDC280KXZE3A	FDC280KXZE3A	FDC280KXZE3A	FDC335KXZE3A	
		FDC224KXZE3A	FDC280KXZE3A	FDC280KXZE3A	FDC280KXZE3A	FDC335KXZE3A	FDC335KXZE3A	
		FDC280KXZE3A	FDC280KXZE3A	FDC280KXZE3A	FDC335KXZE3A	FDC335KXZE3A	FDC335KXZE3A	
Nominal horse power		26	28	30	32	34	36	
Power source		3 Phase 380-415V, 50Hz						
Nominal capacity	Cooling	72.8	78.4	84.0	89.5	95.0	100.5	
	Heating	72.8	78.4	84.0	89.5	95.0	100.5	
Max heating capacity	kW	81.5	88.0	94.5	100.5	106.5	112.5	
Power consumption	Cooling	19.1	21.6	24.1	25.8	27.4	29.0	
	Heating	15.5	17.3	19.0	20.7	22.3	23.9	
EER		3.81	3.62	3.48	3.47	3.46	3.46	
COP		4.69	4.53	4.41	4.32	4.25	4.20	
SEER		9.07	9.02	8.97	8.81	8.68	8.57	
SCOP		4.79	4.78	4.75	4.72	4.69	4.67	
Net weight	kg		786		798	810	822	
Max current	A	64.6	67.1	69.6	72.1	74.6	77.1	
Refrigerant piping size	Liquid	ø15.88 (5/8")						
	Gas	ø34.92 (1-3/8")						
	Oil equalization	ø12.7 (1/2")						
Total piping length	m	1000						
Outdoor operating temperature range	Cooling	°CDB -15 to 52						
	Heating	°CWB -25 to 16						
Capacity connection	%	50-150						
Number of connectable indoor units		2 to 73			2 to 80			

1. The data are measured under the following conditions (ISO-T1, H1). Cooling: Indoor temp. of 27°CDB, 19°CWB, and outdoor temp. of 35°CDB. Heating: Indoor temp. of 20°CDB, and outdoor temp. of 7°CDB, 6°CWB.  
 2. SEER/SCOP are based on EN14825:2018 and Commission regulation (EU) No.2016/2281. Temperature conditions for calculating SCOP are based on "Average climate".  
 3. Sound level indicates the value in an anechoic chamber. During operation these values are somewhat higher due to ambient conditions.  
 4. 'tonne(s) of CO<sub>2</sub> equivalent' means a quantity of greenhouse gases- expressed as the product of the weight of the greenhouse gases in metric tonnes and of their global warming potential.  
 5. When connecting the indoor unit type FDK, FDFL, FDFU or FDFW series, limit the connectable capacity not higher than 130%.

**38, 40HP** (107.0kW, 113.5kW)



**Technical focus**

- Available in the R32 refrigerant
- New exterior design containing cutting edge technology
- High SCOP & SEER with advanced technology
- VTCC+ : advanced variable temperature and capacity control
- Advanced continuous heating

**New**



FDC1060



FDC1120

**■ SPECIFICATIONS**

Item	Model	FDC1060KXZVE3	FDC1120KXZVE3
Combination		FDC335KXZE3A	FDC335KXZE3A
		FDC335KXZE3A	FDC400KXZE3
		FDC400KXZE3	FDC400KXZE3
Nominal horse power		38	40
Power source		3 Phase 380–415V, 50Hz	
Nominal capacity	Cooling	107.0	113.5
	Heating	107.0	113.5
Max heating capacity	kW	120.0	127.5
Power consumption	Cooling	31.1	33.1
	Heating	24.4	24.8
EER		3.44	3.42
COP		4.39	4.57
SEER		8.57	8.58
SCOP		4.62	4.57
Net weight	kg	900	978
Max current	A	83.8	90.5
Refrigerant piping size	Liquid	ø19.05 (3/4")	
	Gas	ø34.92 (1-3/8")	
	Oil equalization	ø12.7 (1/2")	
Total piping length	m	1000	
Outdoor operating temperature range	Cooling	-15 to 52	
	Heating	-25 to 16	
Capacity connection	%	50–150	
Number of connectable indoor units		2 to 80	

1. The data are measured under the following conditions (ISO-T1, H1). Cooling: Indoor temp. of 27°CDB, 19°CWB, and outdoor temp. of 35°CDB. Heating: Indoor temp. of 20°CDB, and outdoor temp. of 7°CDB, 6°CWB.  
 2. SEER/SCOP are based on EN14825:2018 and Commission regulation (EU) No.2016/2281. Temperature conditions for calculating SCOP are based on "Average climate".  
 3. Sound level indicates the value in an anechoic chamber. During operation these values are somewhat higher due to ambient conditions.  
 4. 'tonne(s) of CO<sub>2</sub> equivalent' means a quantity of greenhouse gases- expressed as the product of the weight of the greenhouse gases in metric tonnes and of their global warming potential.  
 5. When connecting the indoor unit type FDK, FDFL, FDFU or FDFW series, limit the connectable capacity not higher than 130%.

**42-48HP** (120.0kW –135.0kW)



**Technical focus**

- Available in the R32 refrigerant
- New exterior design containing cutting edge technology
- High SCOP & SEER with advanced technology
- VTCC+ : advanced variable temperature and capacity control
- Advanced continuous heating

**New**



FDC1175-1340

**SPECIFICATIONS**

Item	Model	FDC1175KXZVE3	FDC1230KXZVE3	FDC1285KXZVE3	FDC1340KXZVE3
Combination		FDC400KXZE3	FDC400KXZE3	FDC400KXZE3	FDC450KXZE3
		FDC400KXZE3	FDC400KXZE3	FDC450KXZE3	FDC450KXZE3
		FDC400KXZE3	FDC450KXZE3	FDC450KXZE3	FDC450KXZE3
Nominal horse power		42	44	46	48
Power source		3 Phase 380-415V, 50Hz			
Nominal capacity	Cooling	120.0	125.0	130.0	135.0
	Heating	120.0	125.0	130.0	135.0
Max heating capacity	kW	135.0	140.0	145.0	150.0
Power consumption	Cooling	35.2	38.4	41.5	44.7
	Heating	25.3	27.0	28.7	30.5
EER		3.41	3.25	3.13	3.02
COP		4.75	4.62	4.52	4.43
SEER		8.58	8.42	8.26	8.10
SCOP		4.52	4.54	4.57	4.59
Net weight	kg	1056			
Max current	A	97.2	101.1	105.0	108.9
Refrigerant piping size	Liquid	ø19.05 (3/4")			
	Gas	ø34.92 (1-3/8")			
	Oil equalization	ø12.7 (1/2")			
Total piping length	m	1000			
Outdoor operating temperature range	Cooling	°CDB -15 to 52			
	Heating	°CWB -25 to 16			
Capacity connection	%	50-150			
Number of connectable indoor units		3 to 80			

1. The data are measured under the following conditions (ISO-T1, H1). Cooling: Indoor temp. of 27°CDB, 19°CWB, and outdoor temp. of 35°CDB. Heating: Indoor temp. of 20°CDB, and outdoor temp. of 7°CDB, 6°CWB.  
 2. SEER/SCOP are based on EN14825:2018 and Commission regulation (EU) No.2016/2281. Temperature conditions for calculating SCOP are based on "Average climate".  
 3. Sound level indicates the value in an anechoic chamber. During operation these values are somewhat higher due to ambient conditions.  
 4. 'tonne(s) of CO<sub>2</sub> equivalent' means a quantity of greenhouse gases- expressed as the product of the weight of the greenhouse gases in metric tonnes and of their global warming potential.  
 5. When connecting the indoor unit type FDK, FDFL, FDFU or FDFW series, limit the connectable capacity not higher than 130%.

# KXZ2 series

# KXZ2



## Flexible Design

The KXZ2 series has a layered design and a refined new form. The flexibility in design and ease of installation are further enhanced to provide optimum response to medium and large building air-conditioning systems.

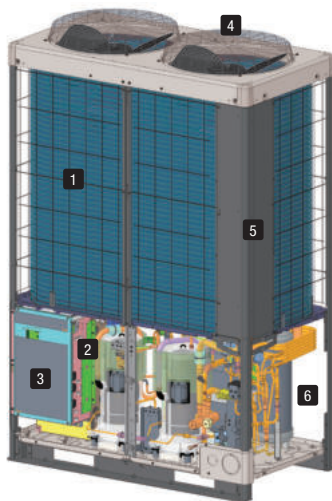

- 1 Highly efficient Heat exchanger
- 2 Optimised duct shape
- 3 Inverter control
- 4 DC Fan Motor
- 5 Rounded design
- 6 Compressor

The compressor has improved the units efficiency by innovating the thrust plate. Resulting a reduced friction loss, and increased reliability.

## Wide range operation

Cooling range operation up to **52°C\***

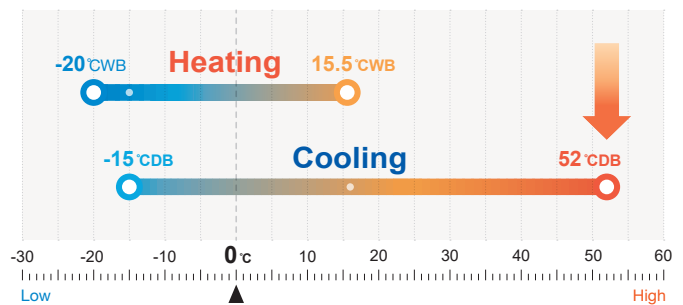

\* With limitation to piping length and height difference between indoor and outdoor units.

## Extended external static pressure

Max:  
**50 Pa to 85 Pa**

Flexibility to meet installation location needs.

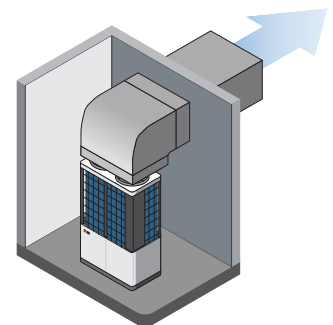

## Indoor unit capacity connection

Increased number of connectable units and max capacity connection

(compared to KXZE1)

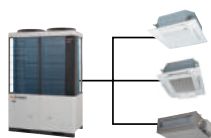

HP	10	12	14	16	17	18	20	22	24	26	28	30	32	34
Numbers	37	44	53	60	50	53	59	65	71	78	80			
IU Capacity connection	50 - 200% (*1)				50 - 160% (*1)									

HP	36	38	40	42	44	46	48	50	52	54	56	58	60
Numbers	80												
IU Capacity connection	50 - 130% (*1)												

(\*1) When connecting the indoor unit type FDK, FDFL, FDFU or FDFW series, limit the connectable capacity not higher than 130%.

## Technology

# CHCC

## Continuous Heating Capacity Control

Our CHCC defrosting control has been added to our KXZ2 system and allows to achieve greater capacities than that of our previous model in low ambient temperature conditions. CHCC controls the target pressure automatically before the capacity drops, which increases the period of heating operation and reduces the systems defrosting time.

# VTCC

## Variable Temperature and Capacity Control

Energy Savings\*  
**34%**

VTCC adjusts the target pressure of the refrigerant cycle in the outdoor unit automatically according to the demand of the indoor units in partial load conditions. These smooth adjustments ensure optimal usage of the indoor units as well as maximised energy savings. Ultimately this also increases comfort for the user.

\* 34% energy savings are based on comparison with a KXZ standard model with VTCC vs. a KXZ standard model both under partial local condition.

## Long Pipe length

Total length

**1000m**

Furthest indoor unit

Actual length **160m**  
Equivalent length **185m**

The maximum height difference between indoor units is a maximum of 30m, and the maximum height difference between the outdoor unit and indoor unit is 90m.

For with few limitations, contributes to system design flexibility.

\*1 The difference between the longest and the shortest indoor unit piping from the first branch must be within 40m. (MAX85m)  
\*2 It is necessary to change the setting corresponding to each height difference in installation. The range of use is also different.

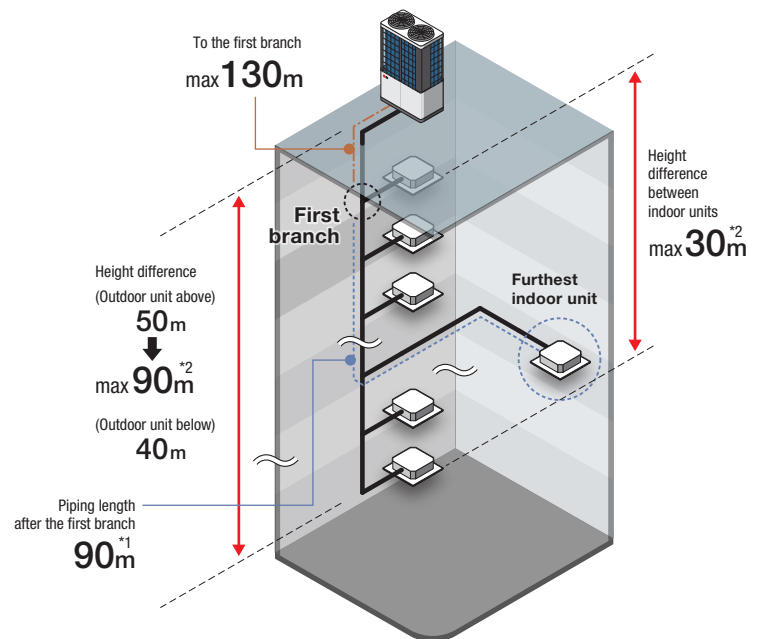

## Field service with smart device

Android™ only

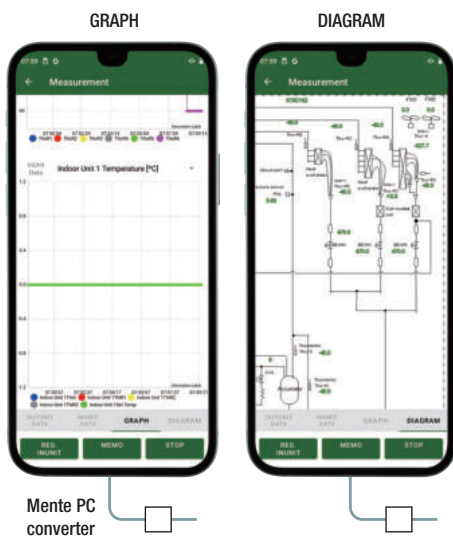

Monitoring and service task could now be done with a smartphone or a tablet by connecting to the Mente PC converter.



The data collected via the smart device could also be sent and viewed with our service software Mente PC.

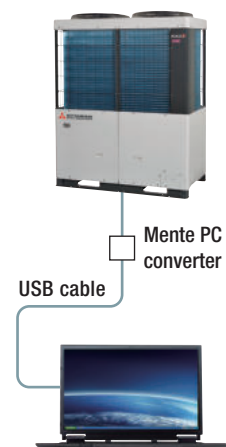

To your PC monitoring and service tasks made simple with our service software (Mente PC).

"Android" is a trademarks or registered trademarks of Google LLC.

## 10, 12HP (28.0kW · 33.5kW)



### Technical focus

- The KXZ2 series has a layered design and a refined new form
- High efficiency with EER up to 3.86
- VTCC : advanced variable temperature and capacity control
- Total piping length up to 1000m and a maximum height difference between indoor units is maximum of 30m.
- Wide range of operation.



Uniform footprint of models allows continuous side-by-side installation



FDC280 · 335

### ■ SPECIFICATIONS

Item		Model	FDC280KXZE2	FDC335KXZE2
Nominal horse power			10HP	12HP
Power source			3 Phase 380-415V, 50Hz	
Nominal capacity	Cooling	kW	28.0	33.5
	Heating	kW	31.5	37.5
Max heating capacity		kW	31.5	37.5
Power consumption <sup>*1</sup>	Cooling	kW	7.25	8.98
	Heating	kW	7.41	9.03
EER <sup>*1</sup>			3.86	3.73
COP <sup>*1</sup>			4.25	4.15
SEER <sup>*1</sup>			7.30	7.54
SCOP <sup>*1</sup>			4.88	4.68
SEER <sup>*2</sup>			7.15	7.40
SCOP <sup>*2</sup>			4.88	4.68
Exterior dimensions (HxWxD)		mm	1697x1350x720	
Net weight		kg	288	
Sound power level <sup>*1</sup>	Cooling	dB(A)	75	82
	Heating	dB(A)	76	81
Sound pressure level	Cooling	dB(A)	56	63
	Heating	dB(A)	57	62
Starting current		A	5	
Max current		A	20.1	
Refrigerant	Type / GWP		R410A / 2088	
	Charge	kg	11.0	
	TCO <sub>2</sub> Eq		22.968	
Refrigerant piping size	Liquid	mm (in)	ø9.52(3/8")	ø12.7(1/2")
	Gas	mm (in)	ø22.22(7/8")	ø25.4(1") [ø22.22(7/8")]
Total piping length		m	1000	
Outdoor operating temperature range	Cooling	°CDB	-15 to 52	
	Heating	°CWB	-20 to 15.5	
Capacity connection		%	50-200	
Number of connectable indoor units			37	44

1. The data are measured under the following conditions (ISO-T1, H1). Cooling: Indoor temp. of 27°CDB, 19°CWB, and outdoor temp. of 35°CDB. Heating: Indoor temp. of 20°CDB, and outdoor temp. of 7°CDB, 6°CWB.  
 2. SEER/SCOP are based on EN14825:2016 and Commission regulation (EU) No.2016/2281. Temperature conditions for calculating SCOP are based on "Average climate".  
 3. Sound level indicates the value in an anechoic chamber. During operation these values are somewhat higher due to ambient conditions.  
 4. 'tonne(s) of CO<sub>2</sub> equivalent' means a quantity of greenhouse gases- expressed as the product of the weight of the greenhouse gases in metric tonnes and of their global warming potential.  
 5. Refrigerant piping size applicable to European installations are shown in parentheses.

\*1 Lot 6/21 performances.

\*2 Seasonal efficiency of Eurovent certification condition SEER/SCOP certified value according to the max air flow limit of 275m<sup>3</sup>/h/kW stated in the Eurovent certification rules.

## 14-20HP (40.0kW – 56.0kW)



### Technical focus

- The KXZ2 series has a layered design and a refined new form
- High efficiency with EER up to 3.64
- VTCC : advanced variable temperature and capacity control
- Total piping length up to 1000m and a maximum height difference between indoor units is maximum of 30m.
- Wide range of operation.



Uniform footprint of all models allows continuous side-by-side installation



FDC400-560

### SPECIFICATIONS

Item	Model	FDC400KXZE2	FDC450KXZE2	FDC475KXZE2	FDC500KXZE2	FDC560KXZE2
Nominal horse power		14HP	16HP	17HP	18HP	20HP
Power source		3 Phase 380-415V, 50Hz				
Nominal capacity	Cooling	40.0	45.0	47.5	50.0	56.0
	Heating	45.0	50.0	53.0	56.0	63.0
Max heating capacity	kW	45.0	50.0	53.0	56.0	63.0
Power consumption <sup>*1</sup>	Cooling	10.98	13.98	13.97	14.01	17.50
	Heating	10.23	12.50	12.99	13.56	16.15
EER <sup>*1</sup>		3.64	3.22	3.40	3.57	3.20
COP <sup>*1</sup>		4.40	4.00	4.08	4.13	3.90
SEER <sup>*1</sup>		7.12	7.01	6.84	7.29	6.73
SCOP <sup>*1</sup>		4.87	4.36	4.45	4.58	4.30
SEER <sup>*2</sup>		7.00	6.90	6.68	7.12	6.60
SCOP <sup>*2</sup>		4.87	4.36	4.45	4.58	4.30
Exterior dimensions (HxWxD)	mm	2052x1350x720				
Net weight	kg	332			378	
Sound power level <sup>*1</sup>	Cooling	80	81	81	81	82
	Heating	82	82	81	82	83
Sound pressure level	Cooling	60	61	61	61	63
	Heating	62	62	61	62	64
Starting current	A	5			8	
Max current	A	32.0			40.2	
Refrigerant	Type / GWP	R410A / 2088				
	Charge	11.5				
	TCO <sub>2</sub> Eq	24.012				
Refrigerant piping size	Liquid	ø12.7(1/2")				
	Gas	ø25.4(1") [ø28.58(1-1/8")]			ø28.58(1-1/8")	
Total piping length	m	1000				
Outdoor operating temperature range	Cooling	-15 to 52				
	Heating	-20 to 15.5				
Capacity connection	%	50-200			50-160	
Number of connectable indoor units		53	60	50	53	59

1. The data are measured under the following conditions (ISO-T1, H1). Cooling: Indoor temp. of 27°CDB, 19°CWB, and outdoor temp. of 35°CDB. Heating: Indoor temp. of 20°CDB, and outdoor temp. of 7°CDB, 6°CWB.  
 2. SEER/SCOP are based on EN14825:2016 and Commission regulation (EU) No.2016/2281. Temperature conditions for calculating SCOP are based on "Average climate".  
 3. Sound level indicates the value in an anechoic chamber. During operation these values are somewhat higher due to ambient conditions.  
 4. 'tonne(s) of CO<sub>2</sub> equivalent' means a quantity of greenhouse gases- expressed as the product of the weight of the greenhouse gases in metric tonnes and of their global warming potential.  
 5. Refrigerant piping size applicable to European installations are shown in parentheses.

\*1 Lot 6/21 performances.

\*2 Seasonal efficiency of Eurovent certification condition SEER/SCOP certified value according to the max air flow limit of 275m<sup>3</sup>/h/kW stated in the Eurovent certification rules.

## 22-26HP (61.5kW – 73.5kW)



### Technical focus

- The KXZ2 series has a layered design and a refined new form
- High efficiency with EER up to 3.79
- VTCC : advanced variable temperature and capacity control
- Total piping length up to 1000m and a maximum height difference between indoor units is maximum of 30m.
- Wide range of operation.



FDC615 · 670



FDC735

### ■ SPECIFICATIONS

Item		Model	FDC615KXZE2	FDC670KXZE2	FDC735KXZE2
Combination (FDC)			280KXZE2	335KXZE2	335KXZE2
			335KXZE2	335KXZE2	400KXZE2
Nominal horse power			22HP	24HP	26HP
Power source			3 Phase 380-415V, 50Hz		
Nominal capacity	Cooling	kW	61.5	67.0	73.5
	Heating	kW	69.0	75.0	82.5
Power consumption	Cooling	kW	16.24	17.96	19.96
	Heating	kW	16.44	18.06	19.26
EER			3.79	3.73	3.68
COP			4.20	4.15	4.28
Net weight		kg	576		
Starting current		A	10		
Max current		A	40.2		
Refrigerant	Type / GWP		R410A / 2088		
	Charge	kg	11.0+11.0		
Refrigerant piping size	Liquid	mm	ø12.7(1/2")		
	Gas	(in)	ø28.58(1-1/8")		
	Oil equalization		ø9.52 (3/8")		
Total piping length		m	1000		
Outdoor operating temperature range	Cooling	°CDB	-15 to 52		
	Heating	°CWB	-20 to 15.5		
Capacity connection		%	50-160		
Number of connectable indoor units			65	71	78

1. The data are measured under the following conditions (ISO-T1, H1). Cooling: Indoor temp. of 27°CDB, 19°CWB, and outdoor temp. of 35°CDB. Heating: Indoor temp. of 20°CDB, and outdoor temp. of 7°CDB, 6°CWB.  
 2. Sound level indicates the value in an anechoic chamber. During operation these values are somewhat higher due to ambient conditions.  
 3. Refrigerant piping size applicable to European installations are shown in parentheses.

## 28-40HP (80.0kW – 112.0kW)



### Technical focus

- The KXZ2 series has a layered design and a refined new form
- High efficiency with EER up to 3.64
- VTCC : advanced variable temperature and capacity control
- Total piping length up to 1000m and a maximum height difference between indoor units is maximum of 30m.
- Wide range of operation.



FDC800-1120

### ■ SPECIFICATIONS

Item	Model	FDC800KXZE2	FDC850KXZE2	FDC900KXZE2	FDC950KXZE2	FDC1000KXZE2	FDC1060KXZE2	FDC1120KXZE2	
Combination (FDC)		400KXZE2	400KXZE2	450KXZE2	475KXZE2	500KXZE2	500KXZE2	560KXZE2	
		400KXZE2	450KXZE2	450KXZE2	475KXZE2	500KXZE2	560KXZE2	560KXZE2	
Nominal horse power		28HP	30HP	32HP	34HP	36HP	38HP	40HP	
Power source		3 Phase 380-415V, 50Hz							
Nominal capacity	Cooling	80.0	85.0	90.0	95.0	100.0	106.0	112.0	
	Heating	90.0	95.0	100.0	106.0	112.0	119.0	126.0	
Power consumption	Cooling	21.96	24.96	27.95	27.94	28.02	31.51	35.00	
	Heating	20.45	22.73	25.00	25.98	27.12	29.71	32.31	
EER		3.64	3.41	3.22	3.40	3.57	3.36	3.20	
COP		4.40	4.18	4.00	4.08	4.13	4.01	3.90	
Net weight	kg	664				756			
Starting current	A	10				16			
Max current	A	64.0				80.4			
Refrigerant	Type / GWP	R410A / 2088							
	Charge	11.5+11.5							
Refrigerant piping size	Liquid	ø15.88(5/8")				ø19.05(3/4")			
	Gas	ø31.75(1-1/4") [ø34.92(1-3/8")]				ø38.1(1-1/2") [ø34.92(1-3/8")]			
	Oil equalization	ø9.52 (3/8")							
Total piping length	m	1000							
Outdoor operating temperature range	Cooling	°CDB -15 to 52							
	Heating	°CWB -20 to 15.5							
Capacity connection	%	50-160				50-130			
Number of connectable indoor units		80							

1. The data are measured under the following conditions (ISO-T1, H1). Cooling: Indoor temp. of 27°CDB, 19°CWB, and outdoor temp. of 35°CDB. Heating: Indoor temp. of 20°CDB, and outdoor temp. of 7°CDB, 6°CWB.  
 2. Sound level indicates the value in an anechoic chamber. During operation these values are somewhat higher due to ambient conditions.  
 3. Refrigerant piping size applicable to European installations are shown in parentheses.

## 42-50HP (120.0kW – 142.5kW)



### Technical focus

- The KXZ2 series has a layered design and a refined new form
- High efficiency with EER up to 3.64
- VTCC : advanced variable temperature and capacity control
- Total piping length up to 1000m and a maximum height difference between indoor units is maximum of 30m.
- Wide range of operation.



FDC1200-1425

### ■ SPECIFICATIONS

Item	Model	FDC1200KXZE2	FDC1250KXZE2	FDC1300KXZE2	FDC1350KXZE2	FDC1425KXZE2
Combination (FDC)		400KXZE2	400KXZE2	400KXZE2	450KXZE2	475KXZE2
		400KXZE2	400KXZE2	450KXZE2	450KXZE2	475KXZE2
		400KXZE2	450KXZE2	450KXZE2	450KXZE2	475KXZE2
Nominal horse power		42HP	44HP	46HP	48HP	50HP
Power source		3 Phase 380-415V, 50Hz				
Nominal capacity	Cooling	120.0	125.0	130.0	135.0	142.5
	Heating	135.0	140.0	145.0	150.0	159.0
Power consumption	Cooling	32.94	35.94	38.93	41.93	41.91
	Heating	30.68	32.95	35.23	37.50	38.97
EER		3.64	3.48	3.34	3.22	3.40
COP		4.40	4.25	4.12	4.00	4.08
Net weight	kg	996				
Starting current	A	15				
Max current	A	96.0				
Refrigerant	Type / GWP	R410A / 2088				
	Charge	11.5+11.5+11.5				
Refrigerant piping size	Liquid	ø19.05(3/4")				
	Gas	ø38.1(1-1/2") [ø34.92(1-3/8")]				
	Oil equalization	ø9.52 (3/8")				
Total piping length	m	1000				
Outdoor operating temperature range	Cooling	-15 to 52				
	Heating	-20 to 15.5				
Capacity connection	%	50-130				
Number of connectable indoor units		80				

1. The data are measured under the following conditions (ISO-T1, H1). Cooling: Indoor temp. of 27°CDB, 19°CWB, and outdoor temp. of 35°CDB. Heating: Indoor temp. of 20°CDB, and outdoor temp. of 7°CDB, 6°CWB.  
 2. Sound level indicates the value in an anechoic chamber. During operation these values are somewhat higher due to ambient conditions.  
 3. Refrigerant piping size applicable to European installations are shown in parentheses.

## 52-60HP (145.0kW – 168.0kW)



### Technical focus

- The KXZ2 series has a layered design and a refined new form
- High efficiency with EER up to 3.57
- VTCC : advanced variable temperature and capacity control
- Total piping length up to 1000m and a maximum height difference between indoor units is maximum of 30m.
- Wide range of operation.



FDC1450-1680

### ■ SPECIFICATIONS

Item	Model	FDC1450KXZE2	FDC1500KXZE2	FDC1560KXZE2	FDC1620KXZE2	FDC1680KXZE2
Combination (FDC)		475KXZE2	500KXZE2	500KXZE2	500KXZE2	560KXZE2
		475KXZE2	500KXZE2	500KXZE2	560KXZE2	560KXZE2
		500KXZE2	500KXZE2	560KXZE2	560KXZE2	560KXZE2
Nominal horse power		52HP	54HP	56HP	58HP	60HP
Power source		3 Phase 380-415V, 50Hz				
Nominal capacity	Cooling	145.0	150.0	156.0	162.0	168.0
	Heating	162.0	168.0	175.0	182.0	189.0
Power consumption	Cooling	41.95	42.03	45.52	49.01	52.50
	Heating	39.54	40.68	43.27	45.87	48.46
EER		3.46	3.57	3.43	3.31	3.20
COP		4.10	4.13	4.04	3.97	3.90
Net weight	kg	1134				
Starting current	A	24				
Max current	A	120.6				
Refrigerant	Type / GWP	R410A / 2088				
	Charge	11.5+11.5+11.5				
Refrigerant piping size	Liquid	ø19.05(3/4")				
	Gas	ø38.1(1-1/2") [ø34.92(1-3/8")]				
	Oil equalization	ø9.52 (3/8")				
Total piping length	m	1000				
Outdoor operating temperature range	Cooling	°CDB -15 to 52				
	Heating	°CWB -20 to 15.5				
Capacity connection	%	50-130				
Number of connectable indoor units		80				

1. The data are measured under the following conditions (ISO-T1, H1). Cooling: Indoor temp. of 27°CDB, 19°CWB, and outdoor temp. of 35°CDB. Heating: Indoor temp. of 20°CDB, and outdoor temp. of 7°CDB, 6°CWB.  
 2. Sound level indicates the value in an anechoic chamber. During operation these values are somewhat higher due to ambient conditions.  
 3. Refrigerant piping size applicable to European installations are shown in parentheses.

## 20-32HP (56.0kW – 89.5kW)



### Technical focus

- The KXZ2 series has a layered design and a refined new form
- High efficiency with EER up to 3.86
- VTCC : advanced variable temperature and capacity control
- Total piping length up to 1000m and a maximum height difference between indoor units is maximum of 30m.
- Wide range of operation.



FDC560



FDC850 · 900

### ■ SPECIFICATIONS

Item		Model	FDC560KXZE2	FDC850KXZE2	FDC900KXZE2
Combination (FDC)			280KXZE2	280KXZE2	280KXZE2
			280KXZE2	280KXZE2	280KXZE2
			-	280KXZE2	335KXZE2
Nominal horse power			20HP	30HP	32HP
Power source			3 Phase 380-415V, 50Hz		
Nominal capacity	Cooling	kW	56.0	84.0	89.5
	Heating		63.0	94.5	100.5
Power consumption	Cooling	kW	14.51	21.76	23.49
	Heating		14.82	22.23	23.85
EER			3.86	3.86	3.81
COP			4.25	4.25	4.21
Net weight		kg	576	864	
Starting current		A	10	15	
Max current		A	40.2	60.3	
Refrigerant	Type / GWP		R410A / 2088		
	Charge	kg	11.0+11.0	11.0+11.0+11.0	
Refrigerant piping size	Liquid	mm	ø12.7(1/2")	ø15.88(5/8")	
	Gas	mm (in)	ø28.58(1-1/8")	ø31.75(1-1/4") [ø34.92(1-3/8")]	
	Oil equalization			ø9.52 (3/8")	
Total piping length		m	1000		
Outdoor operating temperature range	Cooling	°CDB	-15 to 52		
	Heating	°CWB	-20 to 15.5		
Capacity connection		%	80-160		
Number of connectable indoor units			59	80	

1. The data are measured under the following conditions (ISO-T1, H1). Cooling: Indoor temp. of 27°CDB, 19°CWB, and outdoor temp. of 35°CDB. Heating: Indoor temp. of 20°CDB, and outdoor temp. of 7°CDB, 6°CWB.  
 2. Sound level indicates the value in an anechoic chamber. During operation these values are somewhat higher due to ambient conditions.  
 3. Refrigerant piping size applicable to European installations are shown in parentheses.

## 34-40HP (95.0kW – 113.5kW)



### Technical focus

- The KXZ2 series has a layered design and a refined new form
- High efficiency with EER up to 3.77
- VTCC : advanced variable temperature and capacity control
- Total piping length up to 1000m and a maximum height difference between indoor units is maximum of 30m.
- Wide range of operation.



### ■ SPECIFICATIONS

Item	Model	FDC950KXZXE2	FDC1000KXZXE2	FDC1060KXZXE2	FDC1120KXZXE2
Combination (FDC)		280KXZE2	335KXZE2	335KXZE2	335KXZE2
		335KXZE2	335KXZE2	335KXZE2	400KXZE2
		335KXZE2	335KXZE2	400KXZE2	400KXZE2
Nominal horse power		34HP	36HP	38HP	40HP
Power source		3 Phase 380-415V, 50Hz			
Nominal capacity	Cooling	95.0	100.5	107.0	113.5
	Heating	106.5	112.5	120.0	127.5
Power consumption	Cooling	25.22	26.94	28.94	30.94
	Heating	25.47	27.09	28.29	29.48
EER		3.77	3.73	3.70	3.67
COP		4.18	4.15	4.24	4.32
Net weight	kg	864		908	952
Starting current	A	15			
Max current	A	60.3		72.2	84.1
Refrigerant	Type / GWP	R410A / 2088			
	Charge	kg	11.0+11.0+11.0	11.0+11.0+11.5	11.0+11.5+11.5
Refrigerant piping size	Liquid	ø15.88(5/8")		ø19.05(3/4")	
	Gas	ø31.75(1-1/4") [ø34.92(1-3/8")]		ø38.1(1-1/2") [ø34.92(1-3/8")]	
	Oil equalization	ø9.52 (3/8")			
Total piping length	m	1000			
Outdoor operating temperature range	Cooling	°CDB -15 to 52			
	Heating	°CWB -20 to 15.5			
Capacity connection	%	80-160		80-130	
Number of connectable indoor units		80			

1. The data are measured under the following conditions (ISO-T1, H1). Cooling: Indoor temp. of 27°CDB, 19°CWB, and outdoor temp. of 35°CDB. Heating: Indoor temp. of 20°CDB, and outdoor temp. of 7°CDB, 6°CWB.  
 2. Sound level indicates the value in an anechoic chamber. During operation these values are somewhat higher due to ambient conditions.  
 3. Refrigerant piping size applicable to European installations are shown in parentheses.

KXZ2 series

# Heat Recovery Systems

for simultaneous heating and cooling



**KXZ2**

Up to 24HP [67.0kW]  
with 1 single outdoor unit

## Flexibility and Performance

The heat recovery systems operate with 3 inter-connecting pipes, commonly referred to as a '3-pipe system'.

The systems provide both heating and cooling operations simultaneously to individual indoor units according to room conditions or user requirements. The systems incorporate highly sophisticated controls transferring heat load energy from the entire building to provide an efficient, comfortable heating and cooling environment.

The range starts from a cooling capacity of 8 HP (22.4 kW) and expands up to 24 HP (67.0kW) using a single outdoor unit. Outdoor units can also be used as a modular system (twin or triple) providing up to 60 HP (168.0 kW) of cooling capacity.

### Example of simultaneous heating and cooling

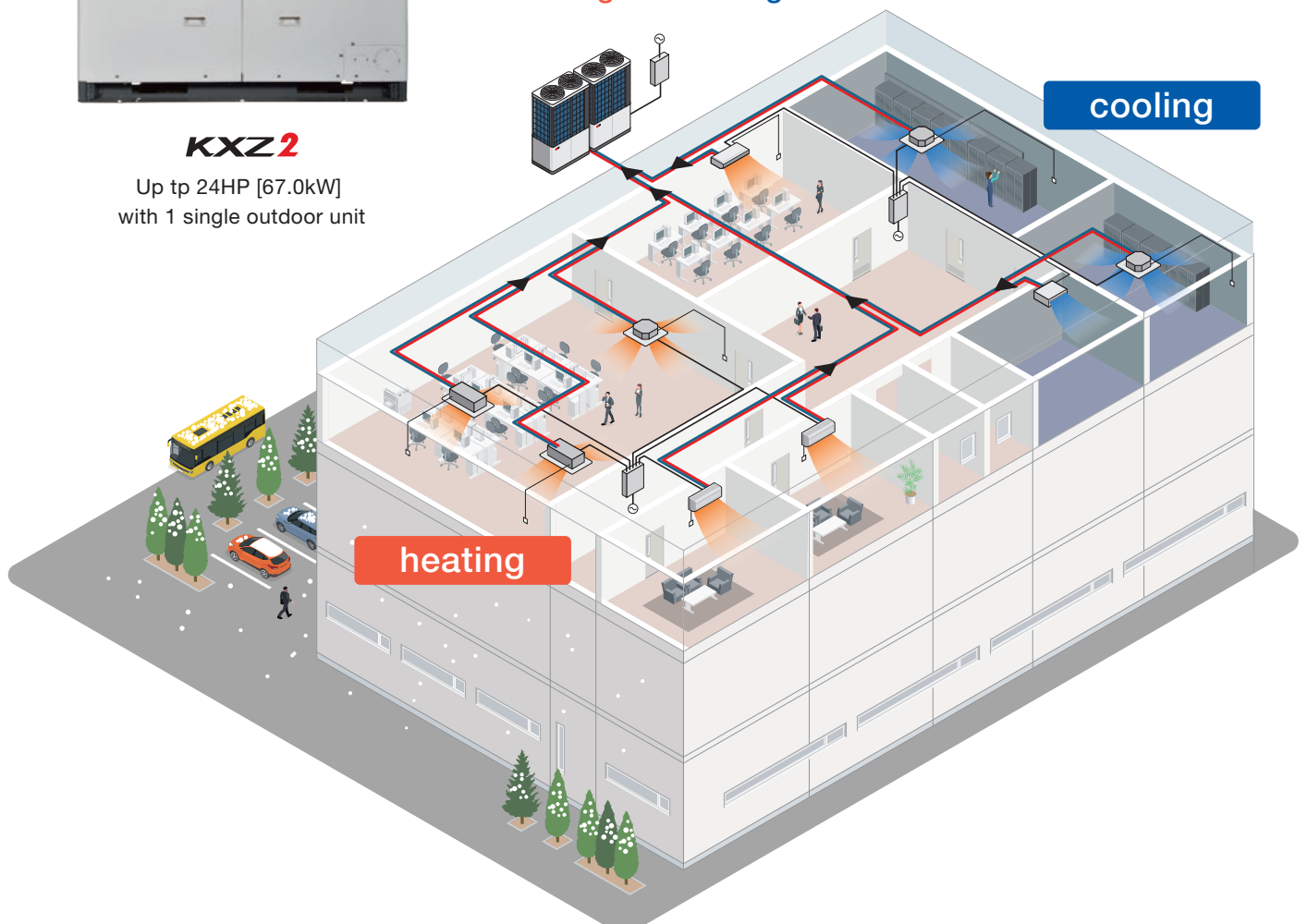

## Heat recovery systems

The system interconnecting pipework has a unique arrangement, with two of the interconnecting pipes routed through a PFD branching control and the third pipe connected directly to each indoor unit from the main pipe run. This reduces installation time, and the number of brazed connections on site. The PFD branching control are available for single connection, or as a combined PFD 4-way connection, with each connected unit having independent cooling or heating operation.

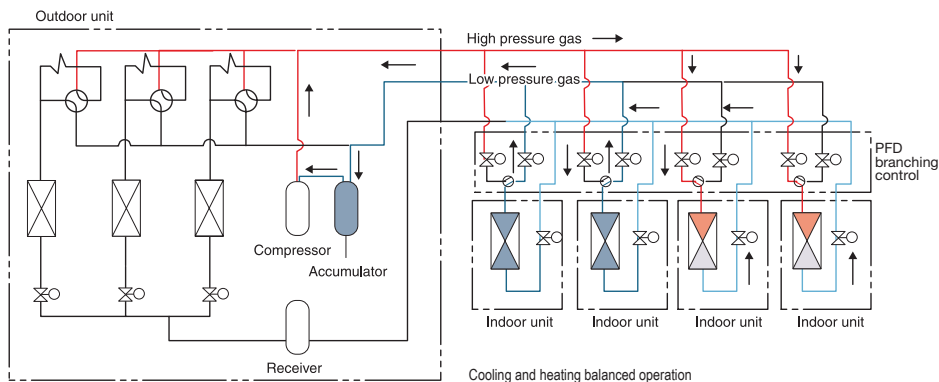

During defrosting or during automatic protection of a compressor, which is activated every several hours in heating operation, heating operation temporarily stops and restarts after some period. The series has the same automatic protection of compressor in cooling operation also. During this protection period air flow only comes on and cooling operation restarts after some period. These models are not suitable for year round cooling applications -such as server rooms- especially in areas where the outdoor air temperature goes below 5°C.

## Heat recovery features

High efficiency in simultaneous heating and cooling mode

Highly efficient operation mode is automatically determined inside the refrigerant system during simultaneous cooling and heating operation. Heat recovery efficiency is maximized by this control and Max COP 9.0 is achieved during operation with simultaneous cooling and heating.

Energy efficiency in heat recovery mode

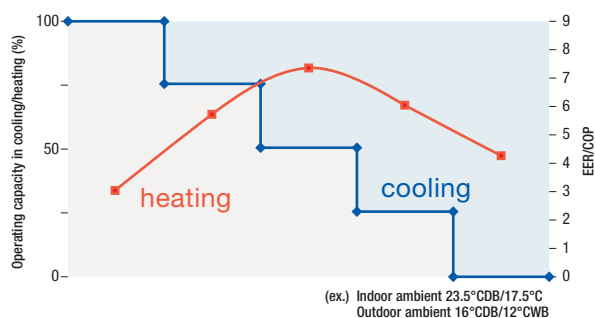

(ex.) Indoor ambient 23.5°CDB/17.5°C  
Outdoor ambient 16°CDB/12°CWB  
(Condition) FDC224KXZRE2  
50% Indoor unit in cooling (27°CDB/19°C)  
50% Indoor unit in heating (20°CDB/14.5°C)  
Outdoor ambient 16°CDB/12°CWB

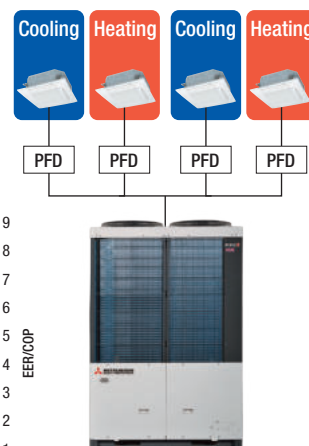

# Technology

## High Efficiency

The graphs below highlight the improved efficiencies of the KXZR and Hi-COP models compared to the previous models.

### Comparison of EER in cooling mode

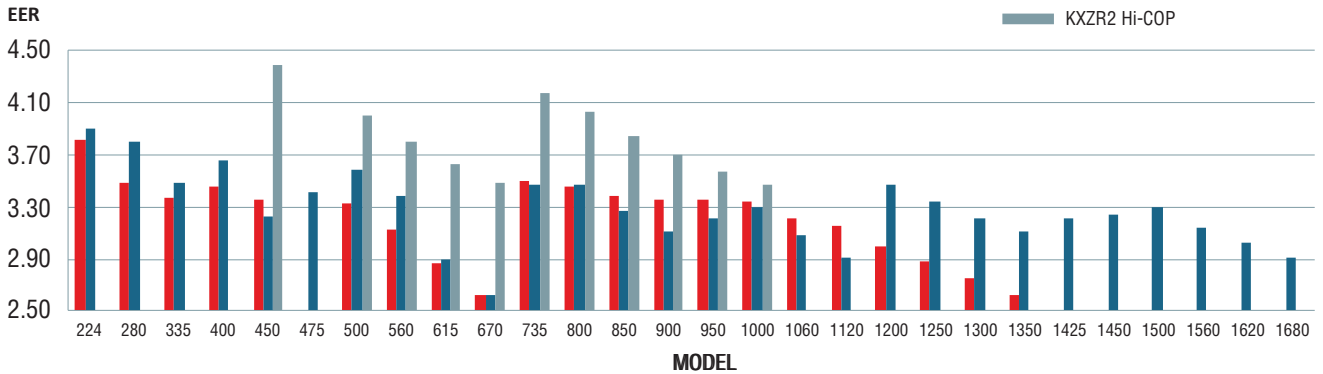

### Comparison of COP in heating mode

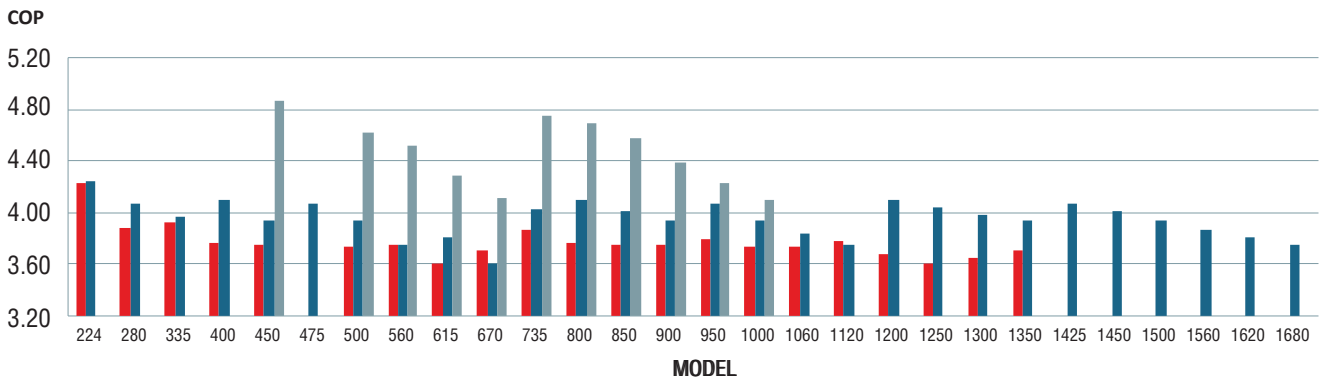

## Continuous Heating Capacity Control (CHCC) -

Our CHCC defrosting control achieves more capacity than that of previous model in low ambient temperature condition. Target pressure is controlled automatically before capacity drops, which makes longer period of heating operation and shorter defrosting time.

## Improved cooling capacity in low ambient temperature

Small split heat exchanger and pressure control make it possible for the outdoor unit to work in cooling operation even at low ambient temperature condition, which achieves more capacity in such low ambient condition as  $-5^{\circ}\text{C}$ , compared to previous model.

In previous model, when high demand for heating and low cooling demand are required at the same time in low ambient temperature condition, pressure control is adjusted to keep more heating capacity than the cooling capacity.

Adopted heat exchanger and pressure control in KXZR series, has improved its capacity for both heating and cooling capacity at the same time. (\*)

(\*) Refrigerant system will prioritize required heating mode more than low cooling demand, in case most of the indoor units are operated in heating mode.

### Blown air temperature in the cooled room

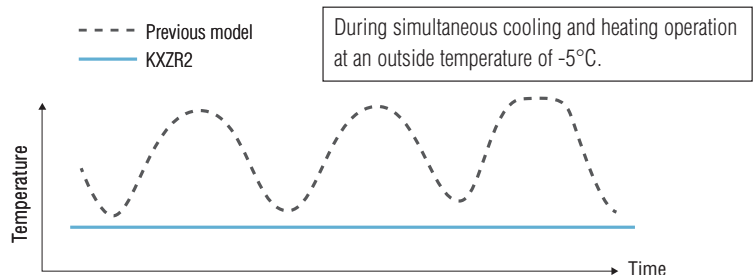

# Design Flexibility

## Indoor unit capacity connection

KXZR	HP	8	10	12	14	16	17	18	20	22	24	26	28	30	32	34	36	38	40	42	44	46	48	50	52	54	56	58	60
	Numbers	29	37	44	53	60	50	53	59	65	71	78	80																
	IU Capacity connection	50-200%					50-160%										50-130%												

KXZR	HP	16	18	20	22	24	26	28	30	32	34	36	
	Numbers	60	53	59	65	71	78	80					
	IU Capacity connection	50-200%	50-160%									50-130%	

## Connectable indoor units

Up to 80 indoor units can be connected to the largest capacity outdoor unit, with a range of 15 types of exposed or concealed indoor unit, in several capacities, a choice of 82 indoor units is available.

- In case that capacity connection is more than 130%, additional charge of refrigerant is required on site.
- In case of 8-34HP of the systems, if one or more indoor units of FDK, FDL, FDFU and/or FDFW series are connected to the system, the total connecting capacity of indoor units should not exceed 130%.

## Wide Range of Operation

KXZR series permits an extensible system design with a heating range operation under a low temperature condition down to -20°C and a cooling range operation up to 46°C

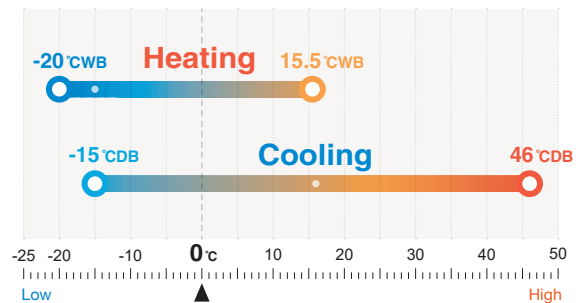

## Long Pipe Length

Total length	Furthest indoor unit	
1000m		
Actual length		160m
	Equivalent length	185m

The maximum height difference between indoor units is a maximum of 18m, and the maximum height difference between the outdoor unit and indoor unit is 50m.

For with few limitations, contributes to system design flexibility.

\*1 The difference between the longest and the shortest indoor unit piping from the first branch must be within 40m.

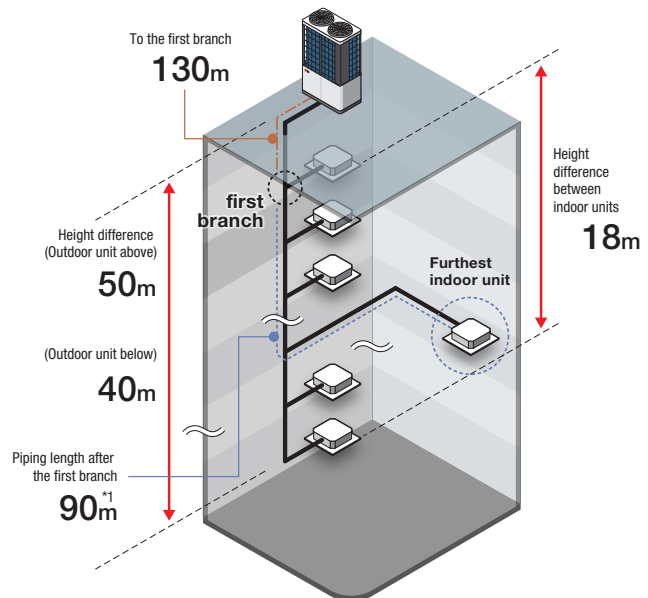

## Improvement of the PFD controller noise level

Sound insulation box design specification, reducing the level of noises from the PFD controller generated due to the flow of refrigerant or other causes.

Sound insulation design



## 8-12HP (22.4kW – 33.5kW)



### Technical focus

- The KXZ2 series has a layered design and a refined new form
- High efficiency with EER up to 3.89
- VTCC : advanced variable temperature and capacity control
- Continuous heating capacity control
- Total piping length up to 1000m and a maximum pipe run of 160m

- for simultaneous heating and cooling



Uniform footprint of models allows continuous side-by-side installation



FDC224-335

### SPECIFICATIONS

Item		Model	FDC224KXZRE2	FDC280KXZRE2	FDC335KXZRE2
Nominal horse power			8HP	10HP	12HP
Power source			3 Phase 380-415V, 50Hz		
Nominal capacity	Cooling	kW	22.4	28.0	33.5
	Heating	kW	22.4	28.0	33.5
Max heating capacity		kW	25.0	31.5	37.5
Power consumption <sup>*1</sup>	Cooling	kW	5.76	7.39	9.65
	Heating	kW	5.27	6.86	8.44
EER <sup>*1</sup>			3.89	3.79	3.47
COP <sup>*1</sup>			4.25	4.08	3.97
SEER <sup>*1</sup>			6.21	6.36	7.15
SCOP <sup>*1</sup>			4.06	4.02	4.43
SEER <sup>*2</sup>			6.21	6.36	7.15
SCOP <sup>*2</sup>			4.05	4.01	4.42
Exterior dimensions (HxWxD)		mm	1697x1350x720		
Net weight		kg	305		
Sound power level <sup>*1</sup>	Cooling	dB(A)	75	75	82
	Heating	dB(A)	77	76	82
Sound pressure level	Cooling	dB(A)	56	55	63
	Heating	dB(A)	58	57	63
Starting current		A	5		
Max current		A	16.0	20.0	21.2
Refrigerant	Type / GWP		R410A / 2088		
	Charge	kg	11.5		
	TCO <sub>2</sub> Eq		24.012		
Refrigerant piping size	Liquid	mm (in)	ø9.52(3/8")		ø12.7(1/2")
	Suction gas	mm (in)	ø19.05(3/4")	ø22.22(7/8")	ø25.4(1") [ø22.22(7/8")]
	Discharge gas	mm (in)	ø15.88(5/8")	ø19.05(3/4")	
Total piping length		m	1000		
Outdoor operating temperature range	Cooling	°CDB	-15 to 46		
	Heating	°CWB	-20 to 15.5		
Capacity connection		%	50-200		
Number of connectable indoor units			29	37	44

1. The data are measured under the following conditions (ISO-T1, H1). Cooling: Indoor temp. of 27°CDB, 19°CWB, and outdoor temp. of 35°CDB. Heating: Indoor temp. of 20°CDB, and outdoor temp. of 7°CDB, 6°CWB. 2. SEER/SCOP are based on EN14825:2016 and Commission regulation (EU) No.2016/2281. Temperature conditions for calculating SCOP are based on "Average climate".

3. Sound pressure level indicates the value in an anechoic chamber. During operation these values are somewhat higher due to ambient conditions.

4. 'tonne(s) of CO<sub>2</sub> equivalent' means a quantity of greenhouse gases- expressed as the product of the weight of the greenhouse gases in metric tonnes and of their global warming potential.

5. Refrigerant piping size applicable to European installations are shown in parentheses.

\*1 Lot 6/21 performances.

\*2 Seasonal efficiency of Eurovent certification condition SEER/SCOP certified value according to the max air flow limit of 275m<sup>3</sup>/h/kW stated in the Eurovent certification rules.

## 14-24HP (40.0kW – 67.0kW)



### Technical focus

- The KXZ2 series has a layered design and a refined new form
- High efficiency with EER up to 3.46
- VTCC : advanced variable temperature and capacity control
- Continuous heating capacity control
- Total piping length up to 1000m and a maximum pipe run of 160m

- for simultaneous heating and cooling



Uniform footprint of all models allows continuous side-by-side installation



FDC400-670

### SPECIFICATIONS

Item	Model	FDC400KXZRE2	FDC450KXZRE2	FDC475KXZRE2	FDC500KXZRE2	FDC560KXZRE2	FDC615KXZRE2	FDC670KXZRE2
Nominal horse power		14HP	16HP	17HP	18HP	20HP	22HP	24HP
Power source		3 Phase 380-415V, 50Hz						
Nominal capacity	Cooling	40.0	45.0	47.5	50.0	56.0	61.5	67.0
	Heating	40.0	45.0	47.5	50.0	56.0	61.5	63.0
Max heating capacity	kW	45.0	50.0	53.0	56.0	63.0	63.0	63.0
Power consumption <sup>*1</sup>	Cooling	11.56	14.47	14.84	15.20	19.31	21.35	25.57
	Heating	9.76	11.39	11.67	12.69	14.93	16.14	17.45
EER <sup>*1</sup>		3.46	3.11	3.20	3.29	2.90	2.88	2.62
COP <sup>*1</sup>		4.10	3.95	4.07	3.94	3.75	3.81	3.61
SEER <sup>*1</sup>		6.78	6.29	6.60	7.01	6.26	6.05	5.88
SCOP <sup>*1</sup>		4.39	4.33	4.27	4.39	4.29	4.34	4.50
SEER <sup>*2</sup>		6.78	6.29	6.60	7.01	6.26	6.05	5.88
SCOP <sup>*2</sup>		4.38	4.32	4.26	4.39	4.29	4.34	4.50
Exterior dimensions (HxWxD)	mm	2052x1350x720						
Net weight	kg	372			420			
Sound power level <sup>*1</sup>	Cooling	81			84			
	Heating	82			83			
Sound pressure level	Cooling	61			65			
	Heating	62			64			
Starting current	A	5			8			
Max current	A	30.0	32.0	40.4	41.0	41.6	42.0	42.4
Refrigerant	Type / GWP	R410A / 2088						
	Charge	11.5						
	TCO <sub>2</sub> Eq	24.012						
Refrigerant piping size	Liquid	ø12.7(1/2")						
	Suction gas	ø25.4(1") [ø28.58(1-1/8")]			ø28.58(1-1/8")			
	Discharge gas	ø22.22(7/8")					ø25.4(1") [ø22.22(7/8")]	
Total piping length	m	50-200			50-160			
Outdoor operating temperature range	Cooling	°CDB -15 to 46						
	Heating	°CWB -20 to 15.5						
Capacity connection	%	50-200			50-160			
Number of connectable indoor units		53	60	50	53	59	65	71

1. The data are measured under the following conditions (ISO-T1, H1). Cooling: Indoor temp. of 27°CDB, 19°CWB, and outdoor temp. of 35°CDB. Heating: Indoor temp. of 20°CDB, and outdoor temp. of 7°CDB, 6°CWB.  
 2. SEER/SCOP are based on EN14825:2016 and Commission regulation (EU) No.2016/2281. Temperature conditions for calculating SCOP are based on "Average climate".  
 3. Sound pressure level indicates the value in an anechoic chamber. During operation these values are somewhat higher due to ambient conditions.  
 4. 'tonne(s) of CO<sub>2</sub> equivalent' means a quantity of greenhouse gases- expressed as the product of the weight of the greenhouse gases in metric tonnes and of their global warming potential.  
 5. Refrigerant piping size applicable to European installations are shown in parentheses.

\*1 Lot 6/21 performances.

\*2 Seasonal efficiency of Eurovent certification condition SEER/SCOP certified value according to the max air flow limit of 275m<sup>3</sup>/h/kW stated in the Eurovent certification rules.

## 26-40HP (73.5kW – 112.0kW)



### Technical focus

- for simultaneous heating and cooling

- The KXZ2 series has a layered design and a refined new form
- High efficiency with EER up to 3.47
- VTCC : advanced variable temperature and capacity control
- Continuous heating capacity control
- Total piping length up to 1000m and a maximum pipe run of 160m



FDC735



FDC800-1120

### ■ SPECIFICATIONS

Item	Model	FDC735KXZRE2	FDC800KXZRE2	FDC850KXZRE2	FDC900KXZRE2	FDC950KXZRE2	FDC1000KXZRE2	FDC1060KXZRE2	FDC1120KXZRE2
Combination (FDC)		335KXZRE2	400KXZRE2	400KXZRE2	450KXZRE2	475KXZRE2	500KXZRE2	500KXZRE2	560KXZRE2
		400KXZRE2	400KXZRE2	450KXZRE2	450KXZRE2	475KXZRE2	500KXZRE2	560KXZRE2	560KXZRE2
Nominal horse power		26HP	28HP	30HP	32HP	34HP	36HP	38HP	40HP
Power source		3 Phase 380-415V, 50Hz							
Nominal capacity	Cooling	73.5	80.0	85.0	90.0	95.0	100.0	106.0	112.0
	Heating	73.5	80.0	85.0	90.0	95.0	100.0	106.0	112.0
Power consumption	Cooling	21.21	23.12	26.03	28.94	29.68	30.40	34.51	38.62
	Heating	18.20	19.52	21.15	22.78	23.34	25.38	27.62	29.86
EER		3.47	3.46	3.27	3.11	3.20	3.29	3.07	2.90
COP		4.04	4.10	4.02	3.95	4.07	3.94	3.84	3.75
Net weight	kg	677	744			840			
Starting current	A	10				16			
Max current	A	51.2	60.0	62.0	64.0	80.8	82.0	82.6	83.2
Refrigerant	Type / GWP	R410A / 2088							
	Charge	11.5+11.5							
Refrigerant piping size	Liquid	ø15.88(5/8")						ø19.05(3/4")	
	Suction gas	ø31.75(1-1/4") [ø34.92(1-3/8")]						ø38.1(1-1/2") [ø34.92(1-3/8")]	
	Discharge gas	ø25.4(1") [ø28.58(1-1/8")]	ø28.58(1-1/8")				ø31.75(1-1/4") [ø28.58(1-1/8")]		
	Oil equalization	ø9.52 (3/8")							
Total piping length	m	1000							
Outdoor operating temperature range	Cooling	-15 to 46							
	Heating	-20 to 15.5							
Capacity connection	%	50-160				50-130			
Number of connectable indoor units		78				80			

1. The data are measured under the following conditions (ISO-T1, H1). Cooling: Indoor temp. of 27°CDB, 19°CWB, and outdoor temp. of 35°CDB. Heating: Indoor temp. of 20°CDB, and outdoor temp. of 7°CDB, 6°CWB.  
 2. Sound level indicates the value in an anechoic chamber. During operation these values are somewhat higher due to ambient conditions.  
 3. Refrigerant piping size applicable to European installations are shown in parentheses.

## 42-50HP (120.0kW – 142.5kW)



### Technical focus

- for simultaneous heating and cooling

- The KXZ2 series has a layered design and a refined new form
- High efficiency with EER up to 3.46
- VTCC : advanced variable temperature and capacity control
- Continuous heating capacity control
- Total piping length up to 1000m and a maximum pipe run of 160m



FDC1200-1425

### ■ SPECIFICATIONS

Item	Model	FDC1200KXZRE2	FDC1250KXZRE2	FDC1300KXZRE2	FDC1350KXZRE2	FDC1425KXZRE2	
Combination (FDC)		400KXZRE2	400KXZRE2	400KXZRE2	450KXZRE2	475KXZRE2	
		400KXZRE2	400KXZRE2	450KXZRE2	450KXZRE2	475KXZRE2	
		400KXZRE2	450KXZRE2	450KXZRE2	450KXZRE2	475KXZRE2	
Nominal horse power		42HP	44HP	46HP	48HP	50HP	
Power source		3 Phase 380-415V, 50Hz					
Nominal capacity	Cooling	kW	120.0	125.0	130.0	135.0	142.5
	Heating		120.0	125.0	130.0	135.0	142.5
Power consumption	Cooling	kW	34.68	37.59	40.50	43.41	44.52
	Heating		29.28	30.91	32.54	34.17	35.01
EER		3.46	3.33	3.21	3.11	3.20	
COP		4.10	4.04	4.00	3.95	4.07	
Net weight	kg	1116				1260	
Starting current	A	15				24	
Max current	A	90.0	92.0	94.0	96.0	121.2	
Refrigerant	Type / GWP	R410A / 2088					
	Charge	kg					
Refrigerant piping size	Liquid	ø19.05(3/4")					
	Suction gas	ø38.1(1-1/2") [ø34.92(1-3/8")]					
	Discharge gas	ø31.75(1-1/4") [ø28.58(1-1/8")]					
	Oil equalization	ø9.52 (3/8")					
Total piping length	m	1000					
Outdoor operating temperature range	Cooling	°CDB					
	Heating	°CWB					
Capacity connection	%	50-130					
Number of connectable indoor units		80					

1. The data are measured under the following conditions (ISO-T1, H1). Cooling: Indoor temp. of 27°CDB, 19°CWB, and outdoor temp. of 35°CDB. Heating: Indoor temp. of 20°CDB, and outdoor temp. of 7°CDB, 6°CWB.  
 2. Sound level indicates the value in an anechoic chamber. During operation these values are somewhat higher due to ambient conditions.  
 3. Refrigerant piping size applicable to European installations are shown in parentheses.

## 52-60HP (145.0kW – 168.0kW)



### Technical focus

- for simultaneous *heating* and *cooling*

- The KXZ2 series has a layered design and a refined new form
- High efficiency with EER up to 3.29
- VTCC : advanced variable temperature and capacity control
- Continuous heating capacity control
- Total piping length up to 1000m and a maximum pipe run of 160m



FDC1450-1680

### ■ SPECIFICATIONS

Item	Model	FDC1450KXZRE2	FDC1500KXZRE2	FDC1560KXZRE2	FDC1620KXZRE2	FDC1680KXZRE2
Combination (FDC)		475KXZRE2	500KXZRE2	500KXZRE2	500KXZRE2	560KXZRE2
		475KXZRE2	500KXZRE2	500KXZRE2	560KXZRE2	560KXZRE2
		500KXZRE2	500KXZRE2	560KXZRE2	560KXZRE2	560KXZRE2
Nominal horse power		52HP	54HP	56HP	58HP	60HP
Power source		3 Phase 380-415V, 50Hz				
Nominal capacity	Cooling	145.0	150.0	156.0	162.0	168.0
	Heating	145.0	150.0	156.0	162.0	168.0
Power consumption	Cooling	44.88	45.60	49.71	53.82	57.93
	Heating	36.03	38.07	40.31	42.55	44.79
EER		3.23	3.29	3.14	3.01	2.90
COP		4.02	3.94	3.87	3.81	3.75
Net weight	kg	1260				
Starting current	A	24				
Max current	A	121.8	123.0	123.6	124.2	124.8
Refrigerant	Type / GWP	R410A / 2088				
	Charge	11.5+11.5+11.5				
Refrigerant piping size	Liquid	ø19.05(3/4")				
	Suction gas	ø38.1(1-1/2") [ø34.92(1-3/8")]				
	Discharge gas	ø31.75(1-1/4") [ø28.58(1-1/8")]				
	Oil equalization	ø9.52 (3/8")				
Total piping length	m	1000				
Outdoor operating temperature range	Cooling	°CDB -15 to 46				
	Heating	°CWB -20 to 15.5				
Capacity connection	%	50-130				
Number of connectable indoor units		80				

1. The data are measured under the following conditions (ISO-T1, H1). Cooling: Indoor temp. of 27°CDB, 19°CWB, and outdoor temp. of 35°CDB. Heating: Indoor temp. of 20°CDB, and outdoor temp. of 7°CDB, 6°CWB.  
 2. Sound level indicates the value in an anechoic chamber. During operation these values are somewhat higher due to ambient conditions.  
 3. Refrigerant piping size applicable to European installations are shown in parentheses.

## 16-24HP (45.0kW – 67.0kW)



### Technical focus

- for simultaneous heating and cooling

- The KXZ2 series has a layered design and a refined new form
- High efficiency with EER up to 3.91
- VTCC : advanced variable temperature and capacity control
- Continuous heating capacity control
- Total piping length up to 1000m and a maximum pipe run of 160m



FDC450-670

### SPECIFICATIONS

Item	Model	FDC450KXZRXE2	FDC500KXZRXE2	FDC560KXZRXE2	FDC615KXZRXE2	FDC670KXZRXE2
Combination (FDC)		224KXZRE2	224KXZRE2	280KXZRE2	280KXZRE2	335KXZRE2
		224KXZRE2	280KXZRE2	280KXZRE2	335KXZRE2	335KXZRE2
Nominal horse power		16HP	18HP	20HP	22HP	24HP
Power source		3 Phase 380-415V, 50Hz				
Nominal capacity	Cooling	45.0	50.0	56.0	61.5	67.0
	Heating	45.0	50.0	56.0	61.5	67.0
Power consumption	Cooling	11.52	13.15	14.78	17.04	19.30
	Heating	10.54	12.13	13.72	15.30	16.88
EER		3.91	3.80	3.79	3.61	3.47
COP		4.27	4.12	4.08	4.02	3.97
Net weight	kg	610				
Starting current	A	10				
Max current	A	32.0	36.0	40.0	41.2	42.4
Refrigerant	Type / GWP	R410A / 2088				
	Charge	11.5+11.5				
Refrigerant piping size	Liquid	ø12.7(1/2")				
	Suction gas	ø28.58(1-1/8")				
	Discharge gas	ø22.22(7/8")		ø25.4(1") [ø22.22(7/8")]		
	Oil equalization	ø9.52 (3/8")				
Total piping length	m	1000				
Outdoor operating temperature range	Cooling	°CDB -15 to 46				
	Heating	°CWB -20 to 15.5				
Capacity connection	%	80-200		80-160		
Number of connectable indoor units		60	53	59	65	71

1. The data are measured under the following conditions (ISO-T1, H1). Cooling: Indoor temp. of 27°CDB, 19°CWB, and outdoor temp. of 35°CDB. Heating: Indoor temp. of 20°CDB, and outdoor temp. of 7°CDB, 6°CWB.  
 2. Sound level indicates the value in an anechoic chamber. During operation these values are somewhat higher due to ambient conditions.  
 3. Refrigerant piping size applicable to European installations are shown in parentheses.

## 26-36HP (73.5kW – 100.0kW)



### Technical focus

- for simultaneous heating and cooling

- The KXZ2 series has a layered design and a refined new form
- High efficiency with EER up to 3.89
- VTCC : advanced variable temperature and capacity control
- Continuous heating capacity control
- Total piping length up to 1000m and a maximum pipe run of 160m



FDC735-1000

### SPECIFICATIONS

Item	Model	FDC735KXZRXE2	FDC800KXZRXE2	FDC850KXZRXE2	FDC900KXZRXE2	FDC950KXZRXE2	FDC1000KXZRXE2	
Combination (FDC)		224KXZRE2	224KXZRE2	280KXZRE2	280KXZRE2	280KXZRE2	335KXZRE2	
		224KXZRE2	280KXZRE2	280KXZRE2	280KXZRE2	335KXZRE2	335KXZRE2	
		280KXZRE2	280KXZRE2	280KXZRE2	335KXZRE2	335KXZRE2	335KXZRE2	
Nominal horse power		26HP	28HP	30HP	32HP	34HP	36HP	
Power source		3 Phase 380-415V, 50Hz						
Nominal capacity	Cooling	kW	73.5	80.0	85.0	90.0	95.0	100.0
	Heating		73.5	80.0	85.0	90.0	95.0	100.0
Power consumption	Cooling	kW	18.91	20.54	22.17	24.43	26.69	28.95
	Heating		17.40	18.99	20.58	22.16	23.74	25.32
EER			3.89	3.89	3.83	3.68	3.56	3.45
COP			4.22	4.21	4.13	4.06	4.00	3.95
Net weight	kg	915						
Starting current	A	15						
Max current	A	52.0	56.0	60.0	61.2	62.4	63.6	
Refrigerant	Type / GWP	R410A / 2088						
	Charge	kg	11.5+11.5+11.5					
Refrigerant piping size	Liquid	ø15.88(5/8")						
	Suction gas	ø31.75(1-1/4") [ø34.92(1-3/8")]						
	Discharge gas	ø25.4(1") [ø28.58(1-1/8")]	ø28.58(1-1/8")				ø38.1(1-1/2") [ø34.92(1-3/8")]	
	Oil equalization	ø9.52 (3/8")						
Total piping length	m	1000						
Outdoor operating temperature range	Cooling	-15 to 46						
	Heating	-20 to 15.5						
Capacity connection	%	80-160						
Number of connectable indoor units		78	80				80-130	

1. The data are measured under the following conditions (ISO-T1, H1). Cooling: Indoor temp. of 27°CDB, 19°CWB, and outdoor temp. of 35°CDB. Heating: Indoor temp. of 20°CDB, and outdoor temp. of 7°CDB, 6°CWB.  
 2. Sound level indicates the value in an anechoic chamber. During operation these values are somewhat higher due to ambient conditions.  
 3. Refrigerant piping size applicable to European installations are shown in parentheses.

# PFD branch control

Branch control	Total downstream indoor unit capacity
PFD1124-E	less than 11.2kW
PFD1804-E	less than 18.0kW
PFD2804-E	28.0kW or less
PFD1124X4-E	less than 37.1kW(less than 11.2kWx4 branches)



Relay kit  
(Relay kit comes attached to the branch control)



4-Way PFD box

## Design flexibility

A total of 37.1 kW group of indoor units can be connected to a PFD box single branch. All connected units will operate in the same mode only (cooling or heating).

The recent 4-way PFD control PFD1124X4-E can connect to up to four indoor units with individual control – allowing for simultaneous cooling or heating.

- The remote control setting (as individual indoor unit on-off, temperature setting other than cooling/heating mode control) is possible with one remote control connected to each indoor unit, while at the same time, Center Control (SC-SL1N/SL2NA/SL5-E) can be used together with the individual remote control.
- It is necessary to set the central control to use this function. Please refer to the Installation Manual for details.
- In case of mode changeover from cooling to heating and from heating to cooling, by the use of only the indoor units and PFD box combination, the mode changeover noise is reduced. All this made possible without turning off the compressor and at the same time without the reduction of capacity. The risk of refrigerant leakage is reduced by adopting brazing structure.
- The use of optional PFD box extension cable that has a connector at ends, makes it possible to further separate the indoor unit and PFD box. This will enable the PFD box to be located away from the indoor unit and help reduce the influence of sound caused by PFD box and refrigerant flow.

Branch control	Total downstream capacity	Connectable indoor units
PFD1124-E	less than 112	1-5
PFD1804-E	112 or more but less than 180	1-8
PFD2804-E	180 or more but less than 280	1-10
PFD1124X4-E	less than 371(less than 112 per branch)	Up to 16

\*Refer to Data Book for details

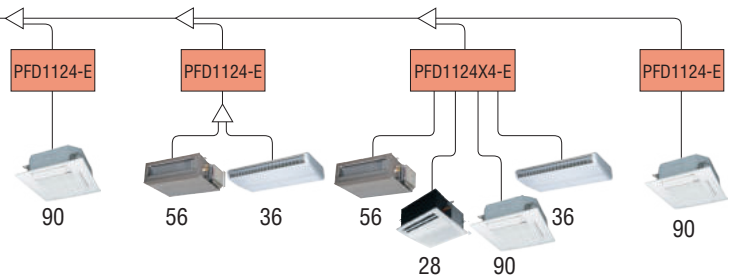

## Easy installation

PFD control box design allows to directly connect the liquid pipe from indoor unit to outdoor unit by bypassing the PFD box. As a result, the piping connections per indoor unit are reduced by a third, thus reducing installation time and cost.

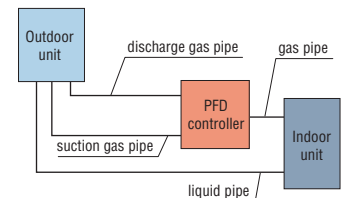

extension cable 15m



PFD4-15WR-E (Option)

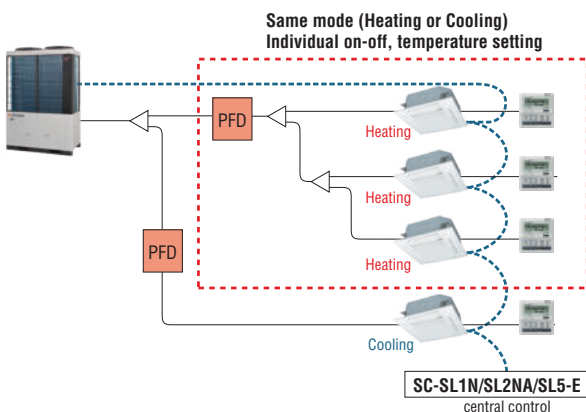

The PFD is connected to the indoor unit by 3 core signal wire via a relay kit (supplied) to be located within 2m of each other. The indoor unit however can be up to 40m away. Power to the PFD can be connected from the indoor unit or other supply.

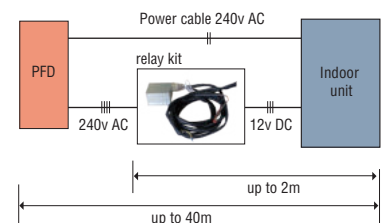

# Micro KXZ series

# Micro KXZ

Space saving for small offices, shops applications



## Micro 4-6HP

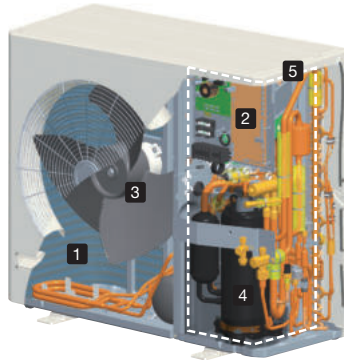

- 1** Heat Exchanger
- 2** Inverter Control  
Vector Inverter Control system
- 3** DC Fan Motor  
Compact & High efficiency
- 4** Twin Rotary Compressor
- 5** System Control

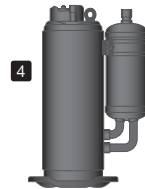

### 1 Compact high efficient Heat Exchanger

- Optimizing relationship of the air flow velocity & fin pattern
- Improvement of air distribution  
Maximizing efficiency of heat exchanger



### 5 Optimum Refrigerant System Control

- Optimum heat exchanger refrigerant distribution
- Advanced refrigerant liquid return protection control system
- High speed system control by Superlink system

## Micro 8-12HP



Previous

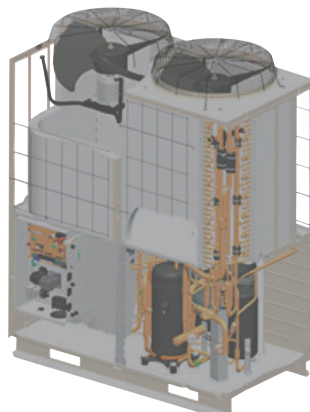

Micro KXZ

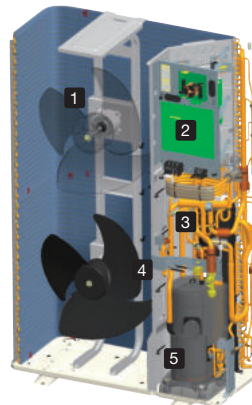

- 1** DC Fan motor  
Compact & High efficiency
- 2** Inverter Control  
Compact & Vector Inverter Control system
- 3** Downsized accumulator
- 4** Receiver in fan section
- 5** Scroll Compressor

# Design Flexibility

## Connectable indoor units & Indoor unit capacity connection

Micro KXZ	HP	4	5	6	8	10	12
	Numbers	8	10*	22	24		
	IU Capacity connection	80 – 150%		50 – 150%			

\*When connecting 9 units or more, set the total capacity as follows :  
5HP : 110% or less, 6HP : 100% or less. In the case of R410A.

KXZ Lite	HP	8	10
	Numbers	8	
	IU Capacity connection	50 – 120%	

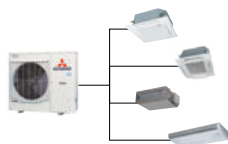

150% capacity connection

## Wide range operation

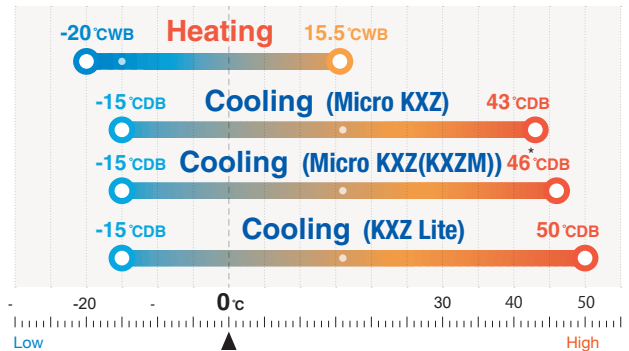

\*With limitation to height difference between indoor and outdoor units and installation space.

## Long Pipe length

### Micro 4–6HP

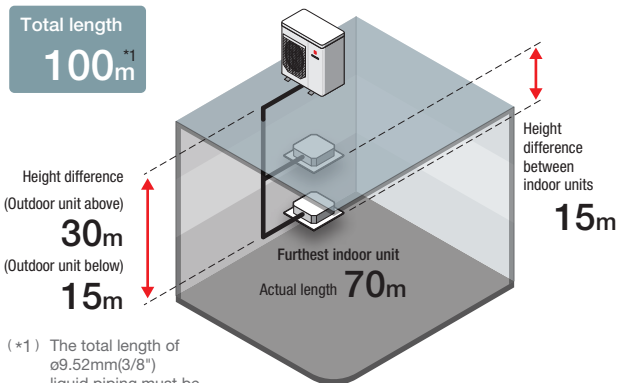

(\*1) The total length of ø9.52mm(3/8") liquid piping must be 50m or less

### Micro 8–12HP

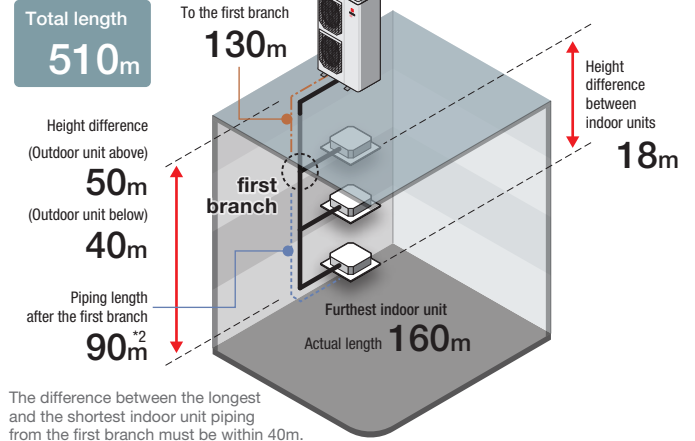

(\*2) The difference between the longest and the shortest indoor unit piping from the first branch must be within 40m.

## Easy Transportation & Installation

Due to realization of significant reduction in size and footprint which is one of the smallest in the industry, transportation in an elevator made for six persons (Width:1400mm, Depth:850, Open area:800mm) is possible, eliminating cost of a crane and reducing labor.

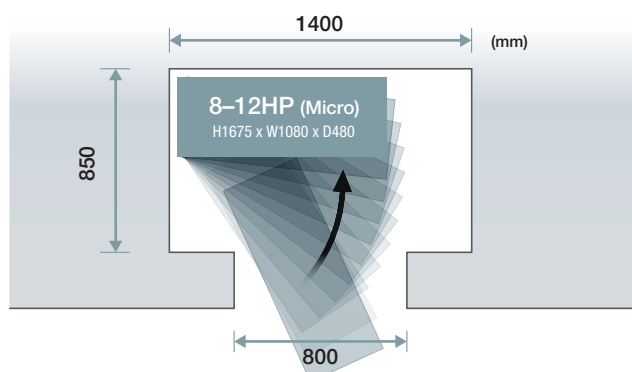

### Transportation in an elevator made for six persons

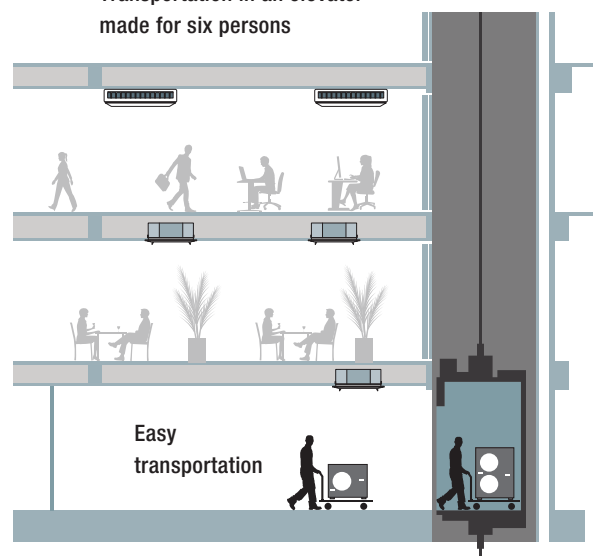

## 4-6 HP (12.1kW – 15.5kW)



### Technical focus

- Compact & flexible design
- High efficiency with EER up to 4.08
- Easy maintenance & Quick installation
- Available in 1-phase (KXZEN1-W) and 3-Phase (KXZES1-W)
- Total piping length up to 100m and a maximum pipe run of 70m



FDC121-155

### SPECIFICATIONS

Item	Model	FDC121KXZEN1-W	FDC140KXZEN1-W	FDC155KXZEN1-W	FDC121KXZES1-W	FDC140KXZES1-W	FDC155KXZES1-W
Nominal horse power		4HP	5HP	6HP	4HP	5HP	6HP
Power source		1 Phase 220-240V, 50Hz			3 Phase 380-415V, 50Hz		
Nominal capacity	Cooling	12.1	14.0	15.5	12.1	14.0	15.5
	Heating	12.1	14.0	15.5	12.1	14.0	15.5
Max heating capacity	kW	12.5	16.0	16.3	12.5	16.0	16.3
Power consumption <sup>*1</sup>	Cooling	2.97	4.00	5.20	2.97	4.00	5.20
	Heating	2.88	3.52	4.06	2.88	3.52	4.06
EER <sup>*1</sup>		4.08	3.50	2.98	4.08	3.50	2.98
COP <sup>*1</sup>		4.20	3.98	3.82	4.20	3.98	3.82
SEER <sup>*1</sup>		9.67	8.82	8.17	9.67	8.82	8.17
SCOP <sup>*1</sup>		4.67	4.62	4.58	4.67	4.62	4.58
SEER <sup>*2</sup>		8.39	7.98	7.57	8.39	7.98	7.57
SCOP <sup>*2</sup>		4.40	4.43	4.41	4.40	4.43	4.41
Exterior dimensions (HxWxD)	mm	845x970x370					
Net weight	kg	85			87		
Sound power level <sup>*1</sup>	Cooling	68	69	70	68	69	70
	Heating	71	73	73	71	73	73
Sound pressure level	Cooling	54	54	54	54	54	54
	Heating	56	58	58	56	58	58
Starting current	A	5					
Max current	A	23.0			13.5		
Refrigerant	Type / GWP	R32 / 675					
	Charge	4.2					
	TCO <sub>2</sub> Eq	2.835					
Refrigerant piping size	Liquid	ø9.52(3/8")					
	Gas	ø15.88(5/8")					
Total piping length	m	100					
Outdoor operating temperature range	Cooling	-15 to 43					
	Heating	-20 to 15.5					
Capacity connection	%	80-150					
Number of connectable indoor units		8	10	10	8	10	10

1. The data are measured under the following conditions (ISO-T1, H1). Cooling: Indoor temp. of 27°CDB, 19°CWB, and outdoor temp. of 35°CDB. Heating: Indoor temp. of 20°CDB, and outdoor temp. of 7°CDB, 6°CWB.

2. SEER/SCOP are based on EN14825:2016 and Commission regulation (EU) No.2016/2281. Temperature conditions for calculating SCOP are based on "Average climate".

3. Sound pressure level indicates the value in an anechoic chamber. During operation these values are somewhat higher due to ambient conditions.

4. 'tonne(s) of CO<sub>2</sub> equivalent' means a quantity of greenhouse gases- expressed as the product of the weight of the greenhouse gases in metric tonnes and of their global warming potential.

5. Refrigerant piping size applicable to European installations are shown in parentheses.

\*1 Lot 6/21 performances.

\*2 Seasonal efficiency of Eurovent certification condition SEER/SCOP certified value according to the max air flow limit of 275m<sup>3</sup>/h/kW stated in the Eurovent certification rules.

## 4-6HP (12.1kW – 15.5kW)



### Technical focus

- Compact & flexible design
- High efficiency with EER up to 3.82
- Easy maintenance & Quick installation
- Available in 1-phase (KXZEN1) and 3-Phase (KXZES1)
- Total piping length up to 100m and a maximum pipe run of 70m



FDC121-155

### SPECIFICATIONS

Item	Model	FDC121KXZEN1	FDC140KXZEN1	FDC155KXZEN1	FDC121KXZES1	FDC140KXZES1	FDC155KXZES1
Nominal horse power		4HP	5HP	6HP	4HP	5HP	6HP
Power source		1 Phase 220-240V, 50Hz			3 Phase 380-415V, 50Hz		
Nominal capacity	Cooling	12.1	14.0	15.5	12.1	14.0	15.5
	Heating	12.1	14.0	15.5	12.1	14.0	15.5
Max heating capacity	kW	12.5	16.0	16.3	12.5	16.0	16.3
Power consumption <sup>*1</sup>	Cooling	3.16	3.96	5.20	3.16	3.96	5.20
	Heating	3.09	3.66	4.28	3.09	3.66	4.28
EER <sup>*1</sup>		3.82	3.54	2.98	3.82	3.54	2.98
COP <sup>*1</sup>		3.91	3.83	3.62	3.91	3.83	3.62
SEER <sup>*1</sup>		8.15	7.73	7.21	8.15	7.73	7.21
SCOP <sup>*1</sup>		4.63	4.59	4.55	4.63	4.59	4.55
SEER <sup>*2</sup>		7.37	7.06	6.68	7.37	7.06	6.68
SCOP <sup>*2</sup>		4.52	4.52	4.41	4.52	4.52	4.41
Exterior dimensions (HxWxD)	mm	845x970x370					
Net weight	kg	85			87		
Sound power level <sup>*1</sup>	Cooling	70	71	71	70	71	71
	Heating	72	72	74	72	72	74
Sound pressure level	Cooling	53	53	54	53	53	54
	Heating	56	57	57	56	57	57
Starting current	A	5					
Max current	A	28.0			13.5		
Refrigerant	Type / GWP	R410A / 2088					
	Charge	5.0					
	TCO <sub>2</sub> Eq	10.44					
Refrigerant piping size	Liquid	ø9.52(3/8")					
	Gas	ø15.88(5/8")					
Total piping length	m	100					
Outdoor operating temperature range	Cooling	-15 to 43					
	Heating	-20 to 15.5					
Capacity connection	%	80-150					
Number of connectable indoor units		8	10 <sup>*3</sup>	10 <sup>*3</sup>	8	10 <sup>*3</sup>	10 <sup>*3</sup>

1. The data are measured under the following conditions (ISO-T1, H1). Cooling: Indoor temp. of 27°CDB, 19°CWB, and outdoor temp. of 35°CDB. Heating: Indoor temp. of 20°CDB, and outdoor temp. of 7°CDB, 6°CWB.

2. SEER/SCOP are based on EN14825:2016 and Commission regulation (EU) No.2016/2281. Temperature conditions for calculating SCOP are based on "Average climate".

3. Sound pressure level indicates the value in an anechoic chamber. During operation these values are somewhat higher due to ambient conditions.

4. 'tonne(s) of CO<sub>2</sub> equivalent' means a quantity of greenhouse gases- expressed as the product of the weight of the greenhouse gases in metric tonnes and of their global warming potential.

5. Refrigerant piping size applicable to European installations are shown in parentheses.

\*1 Lot 6/21 performances.

\*2 Seasonal efficiency of Eurovent certification condition SEER/SCOP certified value according to the max air flow limit of 275m<sup>3</sup>/h/kW stated in the Eurovent certification rules.

\*3 When connecting 9 units or more, set the total capacity as follows : 5HP : 110% or less, 6HP : 100% or less. In the case of R410A.

## 8-12HP (22.4kW – 33.5kW)



### Technical focus

- Compact & flexible design
- High efficiency with EER up to 4.00
- Easy transportation & Quick installation
- Connect up to 24 indoor units / up to 150% capacity
- Total piping length up to 510m and a maximum pipe run of 160m



FDC224-335

### SPECIFICATIONS

Item	Model	FDC224KXZME1	FDC280KXZME1	FDC335KXZME1A
Nominal horse power		8HP	10HP	12HP
Power source		3 Phase 380-415V, 50Hz		
Nominal capacity	Cooling	22.4	28.0	33.5
	Heating	22.4	28.0	33.5
Max heating capacity	kW	25.0	31.5	37.5
Power consumption	Cooling	5.59	7.90	10.68
	Heating	4.97	6.53	8.44
EER		4.00	3.54	3.13
COP		4.50	4.28	3.96
SEER		6.55	6.03	5.84
SCOP		4.55	4.54	4.04
Exterior dimensions (HxWxD)	mm	1675x1080x480		
Net weight	kg	221		224
Sound power level	Cooling	73	75	75
	Heating	75	76	77
Sound pressure level	Cooling	58	60	60
	Heating	59	60	62
Starting current	A	5		
Max current	A	20.0		23.0
Refrigerant	Type / GWP	R410A / 2088		
	Charge	11.5		
	TCO <sub>2</sub> Eq	24.012		
Refrigerant piping size	Liquid	ø9.52(3/8")		ø12.7(1/2")
	Gas	ø19.05(3/4")	ø22.22(7/8")	ø25.4(1") [ø22.22(7/8")]
Total piping length	m	510		
Outdoor operating temperature range	Cooling <sup>*1</sup>	-15 to 46 °CDB		
	Heating	-20 to 15.5 °CWB		
Capacity connection	%	50-150		
Number of connectable indoor units		22	24	24

1. The data are measured under the following conditions (ISO-T1, H1). Cooling: Indoor temp. of 27°CDB, 19°CWB, and outdoor temp. of 35°CDB. Heating: Indoor temp. of 20°CDB, and outdoor temp. of 7°CDB, 6°CWB.  
 2. SEER/SCOP are based on EN14825:2016 and Commission regulation (EU) No.2016/2281. Temperature conditions for calculating SCOP are based on "Average climate".  
 3. Sound pressure level indicates the value in an anechoic chamber. During operation these values are somewhat higher due to ambient conditions.  
 4. 'tonne(s) of CO<sub>2</sub> equivalent' means a quantity of greenhouse gases- expressed as the product of the weight of the greenhouse gases in metric tonnes and of their global warming potential.  
 5. Refrigerant piping size applicable to European installations are shown in parentheses.  
 \*1 With limitation to height difference between indoor and outdoor units and installation space.

## 8, 10HP (22.4kW · 28.0kW)



### Technical focus

- Compact & flexible design
- High efficiency with EER up to 4.00
- KXZ Lite extends a cooling range operation up to 50°C.
- Connect up to 8 indoor units / up to 120% capacity
- Total piping length up to 150m and a maximum pipe run of 120m
- External static pressure is available up to 35 Pa
- Improved installation items

#### Improved freedom of piping layout

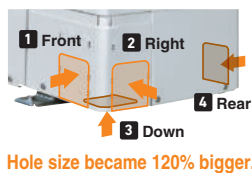

#### A transparent rain cover

Attached as a standard for easy maintenance.

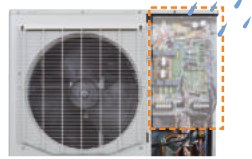

#### Wire insertion holes for fall prevention

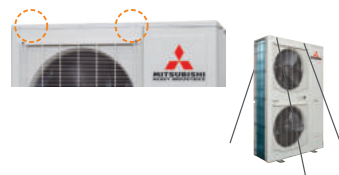

FDC224 · 280

#### Fixing screws to service panel

Decreased number of screws from 5 to 2, installation & service speed is improved.

## SPECIFICATIONS

Item	Model	FDC224KXZPE1	FDC280KXZPE1
Nominal horse power		8HP	10HP
Power source		3 Phase 380-415V, 50Hz	
Nominal capacity	Cooling	22.4	28.0
	Heating	22.4	28.0
Power consumption	Cooling	5.6	7.87
	Heating	4.8	6.47
EER		4.00	3.56
COP		4.67	4.33
SEER		6.65	6.68
SCOP		4.34	4.50
Exterior dimensions (HxWxD)	mm	1505x970x370	
Net weight	kg	165	
Sound power level	Cooling	72	74
	Heating	73	76
Sound pressure level	Cooling	59	60
	Heating	60	63
Starting current	A	5	
Max current	A	21.0	22.0
Refrigerant	Type / GWP	R410A / 2088	
	Charge	8.9	
	TCO <sub>2</sub> Eq	18.583	
Refrigerant piping size	Liquid	ø9.52(3/8")	
	Gas	ø19.05(3/4")	ø22.22(7/8")
Total piping length	m	150	
Outdoor operating temperature range	Cooling	-15 to 50	
	Heating	-20 to 15.5	
Capacity connection	%	50-120	
Number of connectable indoor units		8	

1. The data are measured under the following conditions (ISO-T1, H1). Cooling: Indoor temp. of 27°CDB, 19°CWB, and outdoor temp. of 35°CDB. Heating: Indoor temp. of 20°CDB, and outdoor temp. of 7°CDB, 6°CWB.  
 2. SEER/SCOP are based on EN14825:2016 and Commission regulation (EU) No.2016/2281. Temperature conditions for calculating SCOP are based on "Average climate".  
 3. Sound pressure level indicates the value in an anechoic chamber. During operation these values are somewhat higher due to ambient conditions.  
 4. "tonne(s) of CO<sub>2</sub> equivalent" means a quantity of greenhouse gases- expressed as the product of the weight of the greenhouse gases in metric tonnes and of their global warming potential.  
 5. Refrigerant piping size applicable to European installations are shown in parentheses.

# 8-36HP (22.4kW – 100.0kW)



### Technical focus

- Ideal for high rise buildings, using **water as heat source**

#### 1. High efficiency (EER/COP)

- Energy saving → Reduction of operation cost

#### 2. Compact design

- Easy transportation and installation
- Carriable by elevator

#### 3. BMS (Building Management System)

- Can use the same BMS as air cooled KX
- Available to large-scale and fine control

#### 4. Serviceability & Maintenance

- Service and maintenance of main parts can be done from the front side only
- Useful service tools (Mente-PC, SL-Checker etc.)



FDC224-335



FDC450-670



FDC730-1000

## ■ SPECIFICATIONS

Item	Model	FDC224KXZWE1	FDC280KXZWE1	FDC335KXZWE1	FDC450KXZWE1	FDC500KXZWE1	FDC560KXZWE1
Combination (FDC)		-	-	-	224KXZWE1	224KXZWE1	280KXZWE1
		-	-	-	224KXZWE1	280KXZWE1	280KXZWE1
		-	-	-	-	-	-
Nominal horse power		8HP	10HP	12HP	16HP	18HP	20HP
Power source		3 Phase 380-415V, 50Hz					
Nominal capacity	Cooling	22.4	28.0	33.5	45.0	50.0	56.0
	Heating	25.0	31.5	37.5	50.0	56.0	63.0
Power consumption	Cooling	4.23	5.75	8.13	8.49	9.83	11.5
	Heating	4.24	5.10	6.30	8.47	9.27	10.2
EER		5.30	4.87	4.12	5.30	5.09	4.87
COP		5.90	6.18	5.95	5.90	6.04	6.18
Exterior dimensions (HxWxD)	mm	1100x780x550				-	
Net weight	kg	185				185x2	
Sound pressure level	Cooling	48	50	52	51	52	53
	Heating						
Refrigerant	Type / GWP	R410A / 2088					
	Charge	9.9				9.9+9.9	
	TCO <sub>2</sub> Eq	20.671				-	
Refrigerant piping size	Liquid	ø9.52(3/8")			ø12.7(1/2")		
	Gas	ø19.05(3/4")	ø22.22(7/8")	ø25.4(1") [ø22.22(7/8")]		ø28.58(1-1/8")	
	Oil equalization	-	-	-		ø9.52(3/8")	
Water piping size	Water inlet	R1 1/4					
	Water outlet	R1 1/4					
	Drain outlet	Rp 1/2(internal thread)					
Total piping length	m	510					
Capacity connection	%	50-150					
Number of connectable indoor units		22	28	33	44	50	56

1. The data are measured at the following condition:

Cooling: Indoor temp. of 27 °CDB, 19 °CWB, and heat source unit inlet water temp. of 30 °C, water flow rate 96 L/min  
 Heating: Indoor temp. of 20 °CDB, 15 °CWB, and heat source unit inlet water temp. of 20 °C, water flow rate 96 L/min

2. Refrigerant piping size applicable to European installations are shown in parentheses.

### 1. High-rise Building

- 100m or higher in height

Heat source units on every floor  
- New building projects -

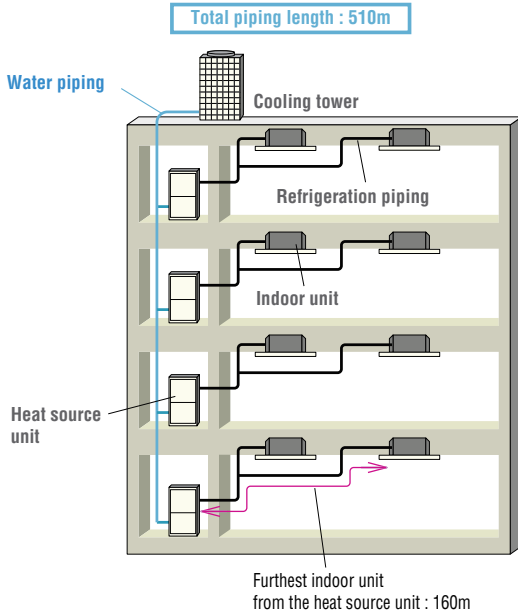

### 2. Glass-exterior facade Building

- Possible to hide KXZW units and to keep fine sight

Heat source units in the machine room  
- Renovation projects -

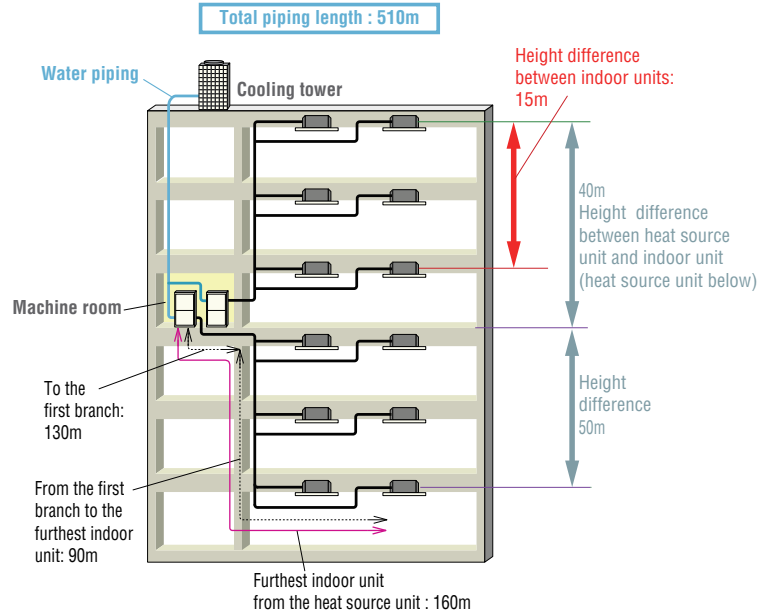

FDC615KXZWE1	FDC670KXZWE1	FDC730KXZWE1	FDC775KXZWE1	FDC850KXZWE1	FDC900KXZWE1	FDC950KXZWE1	FDC1000KXZWE1
280KXZWE1	335KXZWE1	224KXZWE1	224KXZWE1	280KXZWE1	280KXZWE1	280KXZWE1	335KXZWE1
335KXZWE1	335KXZWE1	224KXZWE1	280KXZWE1	280KXZWE1	280KXZWE1	335KXZWE1	335KXZWE1
-	-	280KXZWE1	280KXZWE1	280KXZWE1	335KXZWE1	335KXZWE1	335KXZWE1
22HP	24HP	26HP	28HP	30HP	32HP	34HP	36HP
3 Phase 380-415V, 50Hz							
61.5	67.0	73.0	77.5	85.0	90.0	95.0	100.0
69.0	75.0	82.5	90.0	95.0	100.0	106.0	112.0
13.7	16.3	14.2	15.5	17.5	19.5	21.7	24.3
11.4	12.6	13.8	14.8	15.4	16.4	17.6	18.8
4.49	4.11	5.14	5.00	4.86	4.62	4.38	4.12
6.05	5.95	5.98	6.08	6.17	6.10	6.02	5.96
-	-	-	-	-	-	-	-
370				555			
54	55	54		55	56		57
R410A / 2088							
9.9+9.9				9.9x3			
-				-			
ø12.7(1/2")				ø15.88(5/8")			
ø28.58(1-1/8")				ø31.75(1-1/4") [ø34.92(1-3/8")]			ø38.1(1-1/2") [ø34.92(1-3/8")]
				ø9.52(3/8")			
				R1 1/4			
				R1 1/4			
				Rp 1/2(internal thread)			
				510			
				50-150			
61	67	72	78		80		

# Refrigerant piping

## Refrigerant piping size selection

### Standard (Outdoor unit side branching pipe – Indoor unit side first branching pipe)

#### KXZ3 Series

If the longest distance (measured between the outdoor unit and the farthest indoor unit) is 90m or longer (actual length), change the main pipe size according to the table below.

Outdoor unit capacity	Main pipe size (normal)		Pipe size for an actual length of 90m or longer		mm	inch																														
	Gas pipe	Liquid pipe	Gas pipe	Liquid pipe																																
224	ø19.05 x t1.0	ø9.52 x t0.8	ø22.22 x t1.0	ø12.7 x t0.8	ø9.52	3/8"																														
280	ø22.22 x t1.0		ø22.22 (ø25.4) x t1.0		ø12.7 x t0.8	ø12.7	1/2"																													
335	ø22.22 (ø25.4) x t1.0					ø28.58 x t1.0	ø15.88 x t1.0	ø15.88	5/8"																											
400	ø28.58 (ø25.4) x t1.0		ø12.7 x t0.8		ø15.88 x t1.0			ø19.05	3/4"																											
450	ø28.58 x t1.0	ø15.88 x t1.0		ø19.05 x t1.0		ø22.22	7/8"																													
500						ø12.7 x t0.8	ø15.88 x t1.0	ø19.05 x t1.0	ø25.4	1"																										
530									ø15.88 x t1.0	ø19.05 x t1.0	ø19.05 x t1.0	ø28.58	1-1/8"																							
560												ø19.05 x t1.0	ø19.05 x t1.0	ø19.05 x t1.0	ø31.8	1-1/4"																				
615															ø19.05 x t1.0	ø19.05 x t1.0	ø19.05 x t1.0	ø34.92	1-3/8"																	
670																		ø19.05 x t1.0	ø19.05 x t1.0	ø19.05 x t1.0	ø38.1	1-1/2"														
735																					ø19.05 x t1.0	ø19.05 x t1.0	ø19.05 x t1.0	ø44.45	1-3/4"											
800																								ø19.05 x t1.0	ø19.05 x t1.0	ø19.05 x t1.0	ø19.05 x t1.0									
850																												ø19.05 x t1.0	ø19.05 x t1.0	ø19.05 x t1.0	ø19.05 x t1.0					
900			ø19.05 x t1.0		ø19.05 x t1.0																											ø19.05 x t1.0	ø19.05 x t1.0			
950	ø19.05 x t1.0	ø19.05 x t1.0		ø19.05 x t1.0																														ø19.05 x t1.0		
1000						ø19.05 x t1.0	ø19.05 x t1.0	ø19.05 x t1.0																											ø19.05 x t1.0	
1060									ø19.05 x t1.0	ø19.05 x t1.0	ø19.05 x t1.0																									ø19.05 x t1.0
1120												ø19.05 x t1.0	ø19.05 x t1.0	ø19.05 x t1.0																						
1175															ø19.05 x t1.0	ø19.05 x t1.0	ø19.05 x t1.0																			
1230																		ø19.05 x t1.0	ø19.05 x t1.0	ø19.05 x t1.0																
1285																					ø19.05 x t1.0	ø19.05 x t1.0	ø19.05 x t1.0													
1340																								ø19.05 x t1.0	ø19.05 x t1.0	ø19.05 x t1.0	ø19.05 x t1.0									
1400																												ø19.05 x t1.0	ø19.05 x t1.0	ø19.05 x t1.0	ø19.05 x t1.0					
1450			ø19.05 x t1.0		ø19.05 x t1.0																											ø19.05 x t1.0	ø19.05 x t1.0			
1500	ø19.05 x t1.0	ø19.05 x t1.0		ø19.05 x t1.0																														ø19.05 x t1.0		
1560						ø19.05 x t1.0	ø19.05 x t1.0	ø19.05 x t1.0																											ø19.05 x t1.0	
1620									ø19.05 x t1.0	ø19.05 x t1.0	ø19.05 x t1.0																									ø19.05 x t1.0
1680												ø19.05 x t1.0	ø19.05 x t1.0	ø19.05 x t1.0																						
1735															ø19.05 x t1.0	ø19.05 x t1.0	ø19.05 x t1.0																			
1790																		ø19.05 x t1.0	ø19.05 x t1.0	ø19.05 x t1.0																
1845																					ø19.05 x t1.0	ø19.05 x t1.0	ø19.05 x t1.0													
1900																								ø19.05 x t1.0	ø19.05 x t1.0	ø19.05 x t1.0	ø19.05 x t1.0									
1955																												ø19.05 x t1.0	ø19.05 x t1.0	ø19.05 x t1.0	ø19.05 x t1.0					
2010			ø19.05 x t1.0		ø19.05 x t1.0																											ø19.05 x t1.0	ø19.05 x t1.0			

Use C1220T-1/2H for ø19.05 or larger pipes.  
The pipe size of ( ) is also available to use.

#### KXZ2 Series

If the longest distance (measured between the outdoor unit and the farthest indoor unit) is 90m or longer (actual length), change the main pipe size according to the table below.

Outdoor unit capacity	Main pipe size (normal)		Pipe size for an actual length of 90m or longer		mm	inch																														
	Gas pipe	Liquid pipe	Gas pipe	Liquid pipe																																
280	ø22.22 x t1.0	ø9.52 x t0.8	ø25.4 (ø22.22) x t1.0	ø12.7 x t0.8	ø9.52	3/8"																														
335	ø25.4 (ø22.22) x t1.0				ø28.58 x t1.0	ø12.7 x t0.8	ø12.7	1/2"																												
400	ø25.4 (ø28.58) x t1.0						ø31.8 x t1.1 (ø28.58 x t1.0)	ø15.88 x t1.0	ø15.88	5/8"																										
450	ø28.58 x t1.0				ø12.7 x t0.8	ø15.88 x t1.0			ø19.05 x t1.0	ø19.05	3/4"																									
475		ø12.7 x t0.8	ø15.88 x t1.0	ø19.05 x t1.0			ø19.05 x t1.0	ø22.22		7/8"																										
500								ø15.88 x t1.0		ø19.05 x t1.0	ø19.05 x t1.0	ø19.05 x t1.0	ø25.4	1"																						
560													ø19.05 x t1.0	ø19.05 x t1.0	ø19.05 x t1.0	ø19.05 x t1.0	ø28.58	1-1/8"																		
615																	ø19.05 x t1.0	ø19.05 x t1.0	ø19.05 x t1.0	ø19.05 x t1.0	ø31.8	1-1/4"														
670																					ø19.05 x t1.0	ø19.05 x t1.0	ø19.05 x t1.0	ø19.05 x t1.0	ø34.92	1-3/8"										
735																									ø19.05 x t1.0	ø19.05 x t1.0	ø19.05 x t1.0	ø19.05 x t1.0	ø38.1	1-1/2"						
800																													ø19.05 x t1.0	ø19.05 x t1.0	ø19.05 x t1.0	ø19.05 x t1.0				
850																																	ø19.05 x t1.0	ø19.05 x t1.0	ø19.05 x t1.0	ø19.05 x t1.0
900																																				
950	ø19.05 x t1.0				ø19.05 x t1.0	ø19.05 x t1.0			ø19.05 x t1.0																											
1000		ø19.05 x t1.0	ø19.05 x t1.0	ø19.05 x t1.0			ø19.05 x t1.0																													
1060								ø19.05 x t1.0		ø19.05 x t1.0	ø19.05 x t1.0	ø19.05 x t1.0																								
1120													ø19.05 x t1.0	ø19.05 x t1.0	ø19.05 x t1.0	ø19.05 x t1.0																				
1200																	ø19.05 x t1.0	ø19.05 x t1.0	ø19.05 x t1.0	ø19.05 x t1.0																
1250																					ø19.05 x t1.0	ø19.05 x t1.0	ø19.05 x t1.0	ø19.05 x t1.0												
1300																									ø19.05 x t1.0	ø19.05 x t1.0	ø19.05 x t1.0	ø19.05 x t1.0								
1350																													ø19.05 x t1.0	ø19.05 x t1.0	ø19.05 x t1.0	ø19.05 x t1.0				
1425																																	ø19.05 x t1.0	ø19.05 x t1.0	ø19.05 x t1.0	ø19.05 x t1.0
1450																																				
1500	ø19.05 x t1.0				ø19.05 x t1.0	ø19.05 x t1.0			ø19.05 x t1.0																											
1560		ø19.05 x t1.0	ø19.05 x t1.0	ø19.05 x t1.0			ø19.05 x t1.0																													
1620								ø19.05 x t1.0		ø19.05 x t1.0	ø19.05 x t1.0	ø19.05 x t1.0																								
1680													ø19.05 x t1.0	ø19.05 x t1.0	ø19.05 x t1.0	ø19.05 x t1.0																				

Please use C1220T-1/2H for ø19.05 or larger pipes.  
Pipe sizes applicable to European installations are shown in parentheses.

## Micro KXZ Series

Outdoor unit		Micro KXZ		
		121	140	155
Gas pipe	Furthest indoor unit =<70m	ø15.88		
Liquid pipe		ø9.52		

Outdoor unit		Micro KXZ			KXZ Lite	
		224	280	335	224	280
Gas pipe	Furthest indoor unit =<90m	ø19.05	ø22.22	ø25.4(ø22.22)	ø19.05	ø22.22
Liquid pipe		ø9.52		ø12.7	ø9.52	
Gas pipe	90m =<Furthest indoor unit	ø22.22	ø25.4(ø22.22)		ø22.22	ø25.4/ ø28.58
Liquid pipe		ø12.7			ø9.52	

## Single outdoor unit piping examples:

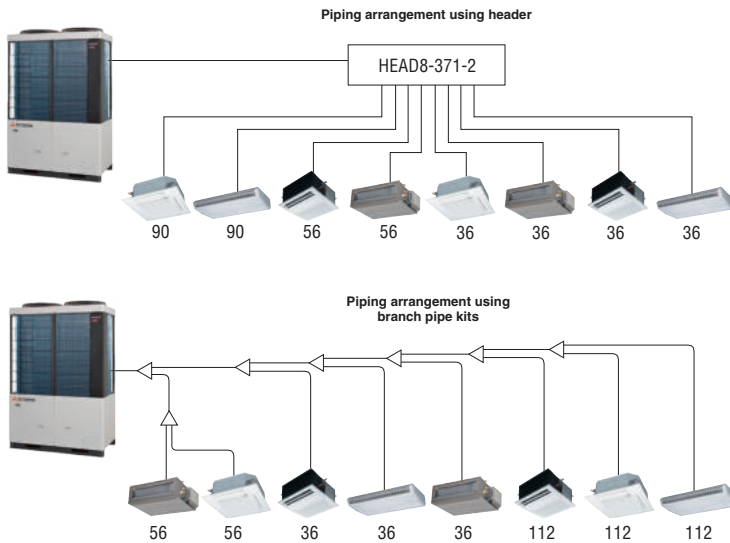

Branch pipes



DIS-22-1G/DIS-180-1G



DIS-371-1G/DIS-540-3

Header pipe



HEAD4-22-1G  
HEAD6-180-1G  
HEAD8-371-2

Combination outdoor unit manifold



DOS-2A-3  
DOS-3A-3

## Combination outdoor unit piping examples:

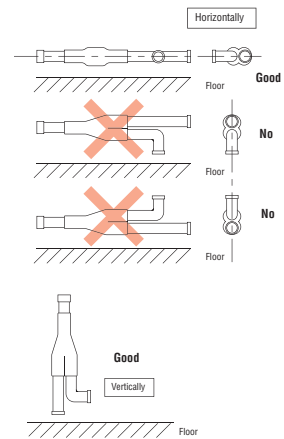
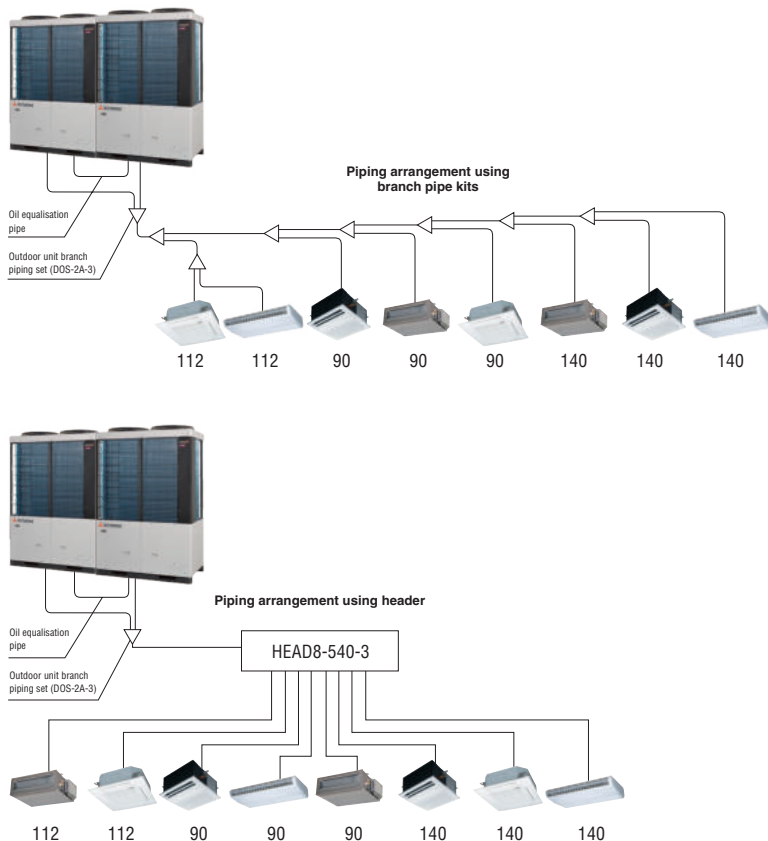

### Outdoor unit side branching pipe set

Outdoor unit	KXZ3	KXZ2
For two units	DOS-2A-4	DOS-2A-3, DOS-2A-4
For three units	DOS-3A-4	DOS-3A-3, DOS-3A-4

### Indoor unit side branching pipe set

Total capacity downstream	For KXZ3 OU	For KXZ2 OU
Less than 180	DIS-22-1G	
180 or more but less than 371	DIS-180-1G	
371 or more but less than 540	DIS-371-1G	
540 or more	DIS-540-4	DIS-540-3, DIS-540-4

### Indoor unit side Header set

Total capacity downstream	For KXZ3 OU	For KXZ2 OU	Number of branches
Less than 180	HEAD4-22-1G	4 branches at the most	
180 or more but less than 371	HEAD6-180-1G	6 branches at the most	
371 or more but less than 540	HEAD8-371-2	8 branches at the most	
540 or more	HEAD8-540-4	HEAD8-540-3, HEAD8-540-4	8 branches at the most

## Heat recovery systems (Outdoor unit side branching pipe – Indoor unit side first branching pipe)

If the longest distance (measured between the outdoor unit and the farthest indoor unit) is 90m or longer (actual length), change the main pipe size according to the table below.

※ Even if the longest distance exceeds 90m (actual length), you do not need to change the size of discharge gas pipes.

Outdoor unit capacity	Main pipe size (normal)			Pipe size for an actual length of 90m or longer			mm	inch
	Suction gas pipe	Discharge gas pipe	Liquid pipe	Suction gas pipe	Discharge gas pipe	Liquid pipe		
224	ø19.05 × t1.0	ø15.88 × t1.0	ø9.52 × t0.8	ø22.22 × t1.0	ø15.88 × t1.0	ø12.7 × t0.8	ø9.52	3/8"
280	ø22.22 × t1.0	ø19.05 × t1.0		ø25.4 (ø22.22) × t1.0	ø19.05 × t1.0		ø22.22 × t1.0	ø12.7
335	ø25.4 (ø22.22) × t1.0		ø28.58 × t1.0					ø31.8 × t1.1 (ø28.58 × t1.0)
400	ø25.4 (ø28.58) × t1.0	ø25.4 (ø22.22) × t1.0		ø25.4 (ø22.22) × t1.0	ø25.4 (ø22.22) × t1.0	ø19.05 × t1.0	ø19.05	
450	ø28.58 × t1.0		ø22.22 × t1.0				ø12.7 × t0.8	ø22.22 × t1.0
475		ø25.4 (ø22.22) × t1.0		ø25.4 (ø22.22) × t1.0	ø31.8 × t1.1 (ø28.58 × t1.0)	ø22.22 × t1.0		
500			ø31.8 × t1.1 (ø34.92 × t1.2)				ø28.58 (ø25.4) × t1.0	ø15.88 × t1.0
560		ø38.1 × t1.35 (ø34.92 × t1.2)		ø31.8 × t1.1 (ø28.58 × t1.0)	ø19.05 × t1.0	ø31.8 × t1.1 (ø28.58 × t1.0)		
615			ø38.1 × t1.35 (ø34.92 × t1.2)				ø31.8 × t1.1 (ø28.58 × t1.0)	ø19.05 × t1.0
670		ø38.1 × t1.35 (ø34.92 × t1.2)		ø31.8 × t1.1 (ø28.58 × t1.0)	ø19.05 × t1.0	ø31.8 × t1.1 (ø28.58 × t1.0)		
735	ø38.1 × t1.35 (ø34.92 × t1.2)		ø31.8 × t1.1 (ø28.58 × t1.0)				ø19.05 × t1.0	ø31.8 × t1.1 (ø28.58 × t1.0)
800								
850								
900								
950								
1000								
1060								
1120								
1200								
1350								
1425								
1450								
1500								
1560								
1620								
1680								

Please use C1220T-1/2H for ø19.05 or larger pipes.  
Pipe sizes applicable to European installations are shown in parentheses.

## Single outdoor unit piping examples:

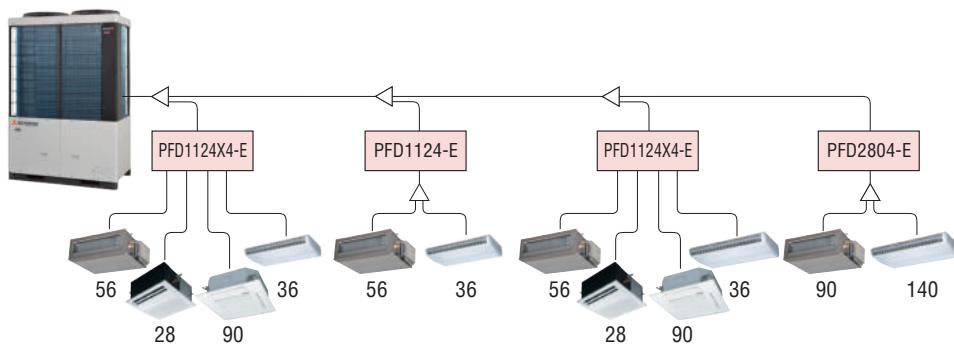
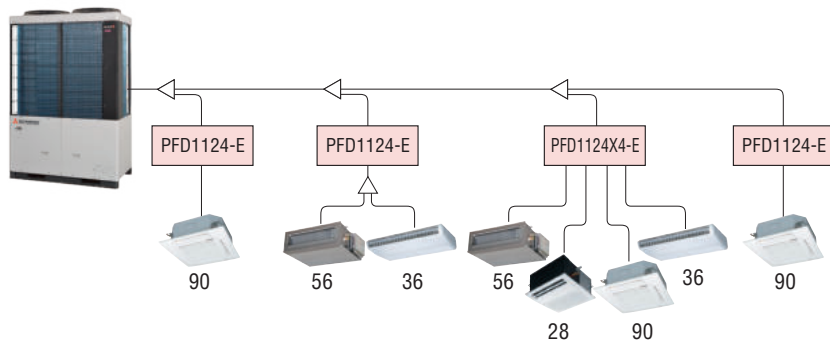

Branch pipes

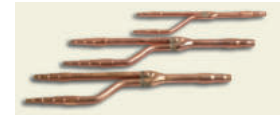

DIS-22-1-RG/DIS-180-1-RG

Combination outdoor unit manifold



DOS-2A-3-R  
DOS-3A-3-R

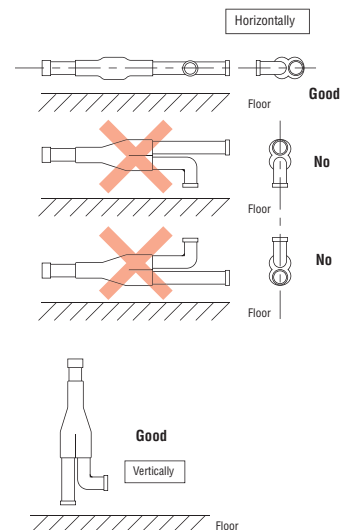

## Combination outdoor unit piping examples:

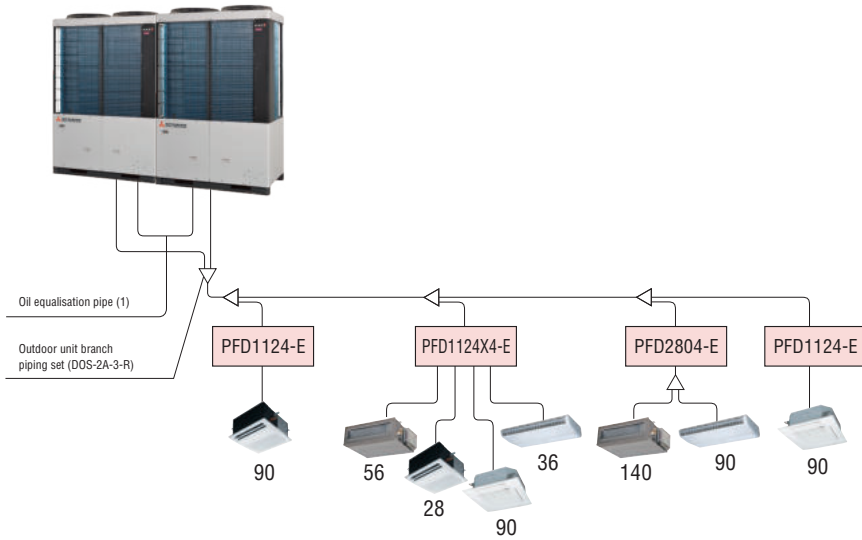

Outdoor unit's branch piping set

Outdoor unit	Branch piping set
2 units	DOS-2A-3-R
3 units	DOS-3A-3-R

Indoor unit's first branch piping set

Total capacity of indoor units	Branch piping set
Less than 180	DIS-22-1-RG
180 or more but less than 371	DIS-180-1-RG
371 or more but less than 540	DIS-371-2-RG
540 or more	DIS-540-2-RG

In the Down Stream of branching control

Total capacity of indoor units	Branch piping set
Less than 180	DIS-22-1-G
180 or more but less than 371	DIS-180-1-G
371 or more but less than 540	DIS-371-1-G
540 or more	DIS-540-3

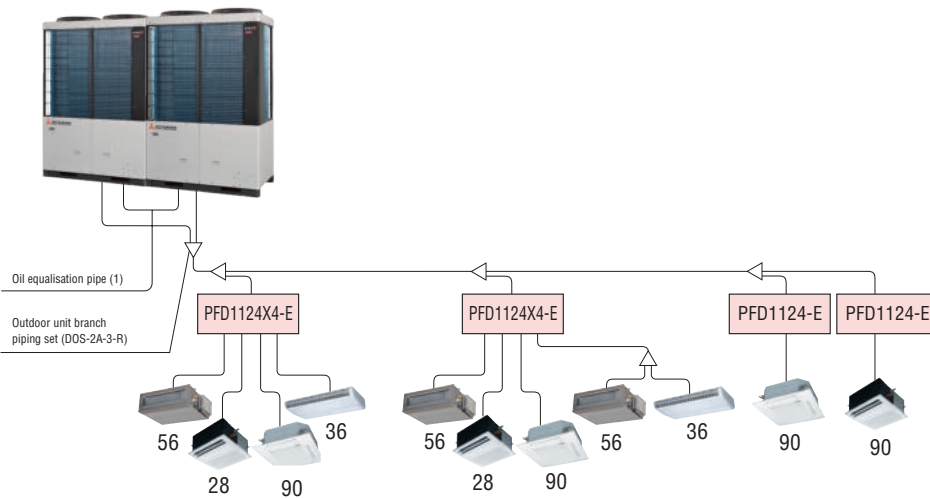

# KXZ series product Line up

## Indoor units



18 types of exposed or concealed indoor units available in a wide range of capacities. The best solution of indoor units for all applications is available from our full lineup.

			1.5kW	2.2kW	2.8kW	3.6kW	4.5kW	
			0.5HP	0.8HP	1HP	1.25HP	1.6HP	
Ceiling Cassette	4way <b>FDT</b>				● ●	● ●	● ●	
	4way Compact <b>FDTC</b>		● ●	● ●	● ●	● ●	● ●	
	2way <b>FDTW</b>				● ●		● ●	
	1way <b>FDTS</b>						● ●	
	1way Compact <b>FDTQ</b>			● ●	● ●	● ●		
Duct Connected	High Static Pressure <b>FDU</b>						● ●	
	Low/Middle Static Pressure <b>FDUM</b>			● ●	● ●	● ●	● ●	
	Low Static Pressure(thin) <b>FDUT</b>		● ●	● ●	● ●	● ●	● ●	
	Compact & Flexible <b>FDUH</b>			● ●	● ●	● ●		
Wall Mounted <b>FDK</b>		● ●	● ●	● ●	● ●	● ●		
Ceiling Suspended <b>FDE</b>					● ●	● ●		
Floor Standing	2way <b>FDFW</b>				● ●		● ●	
	With Casing <b>FDFL</b>							
	Without Casing <b>FDFU</b>				● ●		● ●	
OA Processing unit <b>FDU-F *</b>								
Hydro module unit <b>HMU</b>								
<b>Air flow m³/h</b>			<b>150</b>	<b>250</b>	<b>350</b>	<b>500</b>		
Fresh Air Ventillation & Heat Exchange unit <b>SAF</b>			●	●	●	●		
Fresh Air Assembly <b>SAF-DX</b>				●	●	●		































































































\* Can not be connected to the Micro model(4-6HP), KXZ Lite.

Combination for KXZ outdoor units

Refrigerant	 : R32 <b>KXZ3</b> <i>Micro KXZ</i>	 : R410A <b>KXZ2</b> <i>Micro KXZ</i>
-------------	--	--



For the R32 Micro KXZ series the safety system of MHI has not been prepared.

	5.6kW	7.1kW	9.0kW	11.2kW	14.0kW	16.0kW	22.4kW	28.0kW
	2HP	2.5HP	3.2HP	4HP	5HP	6HP	8HP	10HP
	 	 	 	 	 	 		
	 							
	 	 	 	 	 			
		 						
	 	 	 	 	 	 	  *	  *
	 	 	 	 	 	 		
	 	 						
	 	 	 					
	 	 		 	 			
	 							
		 						
	 	 						
			 		 		 	 
								
	800	1000						
								
								

# New Generation FDT



## New *Automatic anti-draft control*

A corner-mounted motion sensors detects human presence and activity in a room, enhancing comfort.

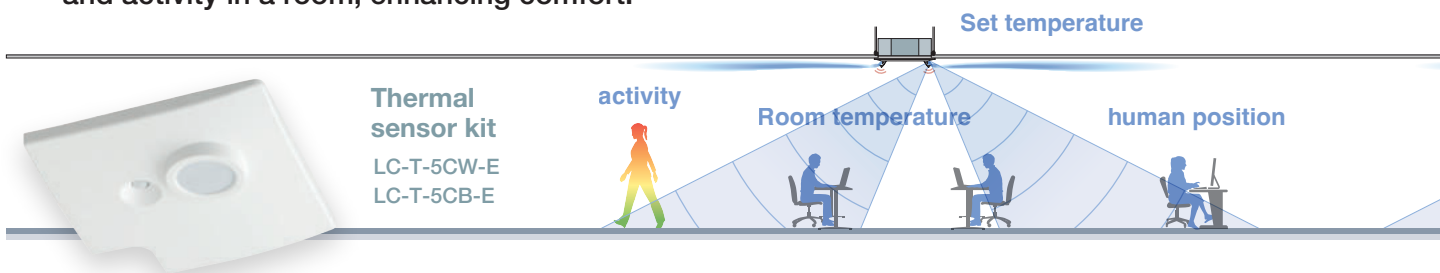

### 1. Air flow based on human position

### 2. Anti-draft control for all directions

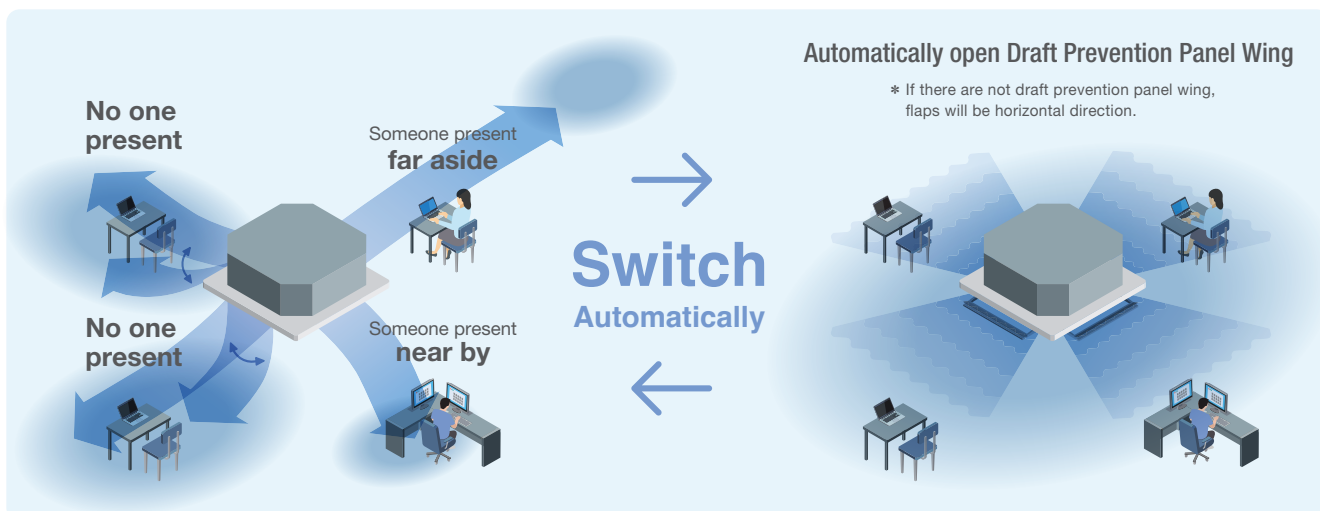

**New**

## Thermal sensing soothing comfort

A Sensor to optimize the air flow

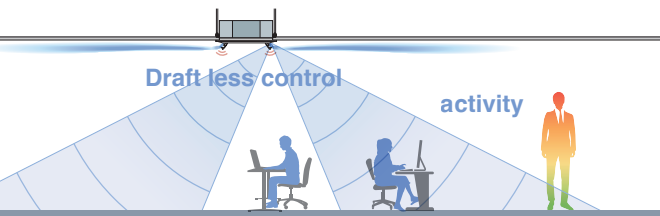

### Direct flow control

The louvers are controlled to blow towards human position.

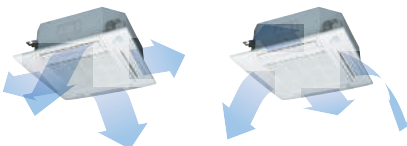

### Draft less control

Draft prevention panel is activated based on human position.



## **New** Improved performance

Power consumption decreased by:

1. Adopting new designed impeller and flow path

improves the aerodynamic performance of the unit.



2.  $\Phi 5.0$  heat exchanger tube is adopted to improve the performance

Slimmer heat exchanger and a dense copper piping.

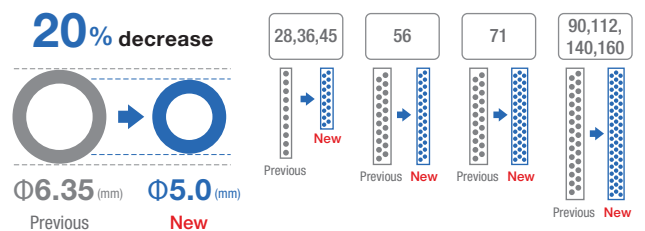

# Draft Prevention Panel (Option)

Keep maximum comfort with minimal draft : FDT & FDTC control flaps with more flexibility.

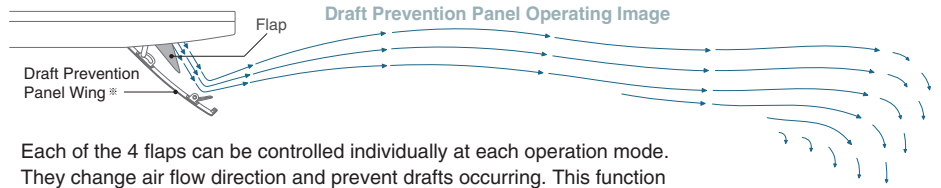

Each of the 4 flaps can be controlled individually at each operation mode. They change air flow direction and prevent drafts occurring. This function also provides flexible control for air flow direction. User can position Draft Prevention Panel panels by using only the remote controller (RC-EX3D, Wireless kit).

- It can also prevent user from being directly blown by hot drafts in heating mode.



Draft Prevention Panel provides a comfortable air flow without any draft feeling. Whether cooling or heating a room, the remote control can be used to instantly suppress any warm or cool drafts. This accurately assists how air flow is directed out of the indoor unit.

# Motion sensor (Option)



## Three Steps Control

### 1 Power Control

Motion sensor (option) detects human activity. Energy saving control is achieved by shifting set temperature according to detected amount of activity.

### 2 Stand by

Unit will go on stand-by mode when no activity is detected. When the motion sensor detects activity again, the unit will automatically re-start operation.

### 3 Auto Off

Unit will go off automatically when no activity is detected for 12 hours.

Operation mode and Control of Motion sensor

		eco operation		comfort operation		
		Operation mode				
Power Control <sup>*1</sup>	Human activity	Auto	Cool	Heat	Dry	Fan
		Low	Cooling +3°C	+3°C	+3°C	-
	Heating +3°C					
	High	Cooling -3°C	-3°C	-3°C	-	-
		Heating -3°C				
	None	Cooling -3°C	+3°C	-3°C	-	-
Heating -3°C						
Auto Off <sup>*2</sup>		●	●	●	●	●

\*1 Set temperature is controlled maximum ±3°C in 0.5°C increments against remote control set temperature by detecting human activity.

\*2 Absence for 1hour ⇒ Operation stops by stand-by mode, then 12hours (can be changed between 1 to 50 hours) absence ⇒ Operation stops completely.

# Wireless Control System Now available in our FDT series

Control your air-conditioner from anywhere, anytime.

If you turn on the air-conditioner when you're on the go, you'll be comfortable when you get to the office. Even if you forget to turn it off, you can turn it off when you are out.



**WF-PAC-E**



You can control the air-conditioner at home or on the go by installing App (Smart M-Air) on your smartphone or tablet.



Search for "Smart M-Air" from the Google Play™ store for Android™ and App Store for iPhone.



Application compatible model:

Please check the app stores for the latest supported OS version information.

App Store and iPhone are registered trademarks of Apple Inc. Google Play and the Google Play logo are trademarks of Google LLC.

### Functions

- 1 Turn ON/OFF
- 2 Change operation mode (Auto, Cool, Heat, Fan, Dry)
- 3 Control temperature
- 4 Set Timers
- 5 Favourite setting

### Notification Function

- 1 Shut-off reminder alert
- 2 Accidentally left running  
It will be sent to your smart device if the air-conditioner is accidentally left running
- 3 Watching function

### Weekly Timer

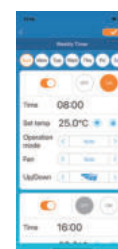

Timers can be set for different days of the week. They can also be set from the calendar.

### System configuration

Smartphone / Tablet



Internet



Router

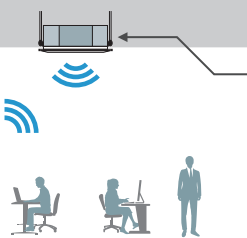

**WF-PAC-E**



\* For the units that does not include wireless LAN the function could be used by adopting an option (WF-PAC-E)

# Indoor unit

# Serviceability & workability

## Easy and quick installation and maintenance

Quick positioning!

### Indoor unit is easily positioned and installed

**1** Adjustable easier positioning of unit by new slits **FDT**

New shape of slit is suitable to install the unit with more flexibility, compatible with many kinds of suspending bolt pitch on site. Any rectangular or squared pitch of suspending bolts are available with this slit.

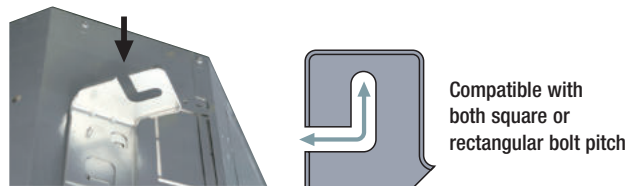

**2** New slit in panel allows easier installation on site **FDT** **FDTC**

Flexible positioning is available, which helps adjusting the direction of panel accordingly to lines or pattern on the ceiling.

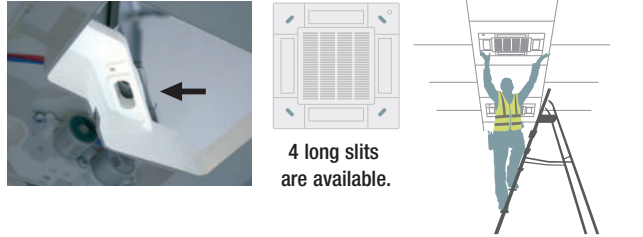

### Quick installation and maintenance

**1** Easy access to component part for easy maintenance **FDT**

1. The control box and bell mouth can be removed together.
2. Easy access to impeller and fan motor.

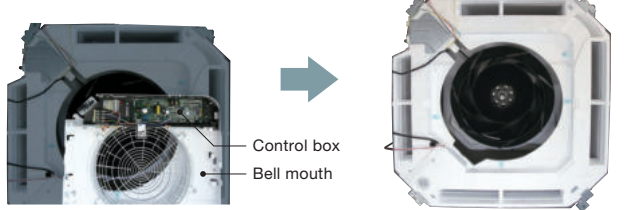

**2** New shape of path of wiring **FDT**

New shape of path gives easy wiring work for installation.

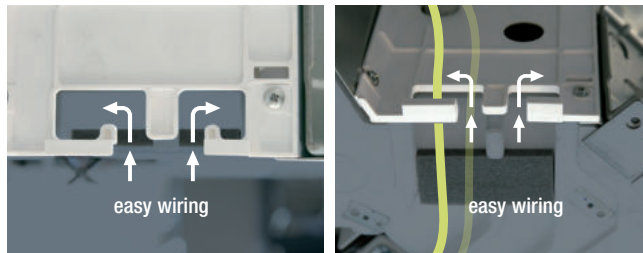

**3** No need to remove screws to open the controller cover **FDT**

It is possible to loose and slide open the cover without removing the screws. This prevents the cover from falling and causing damage on site.

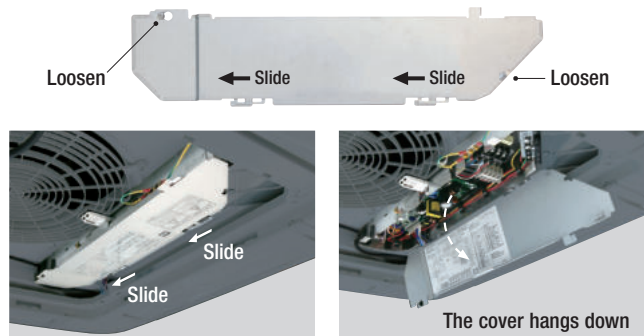

**4** More safe installation by stopper of washer **FDT** **FDTC**

When unit is installed with hook between washers, this stopper helps to install the unit safely, without adjusting washer.

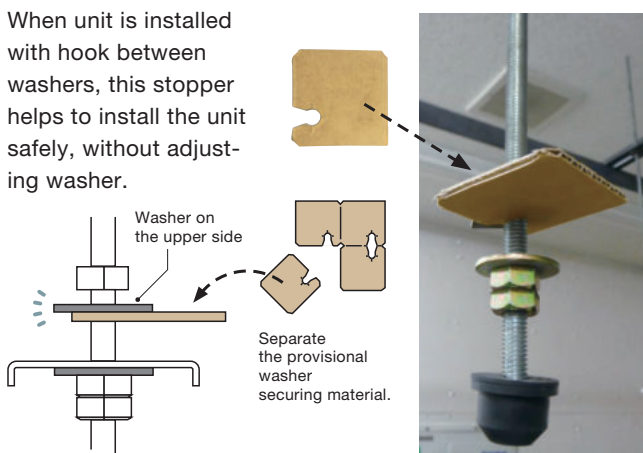

## Easy installation and maintenance

For smooth and easy working

### 1 Easy and flexible hook to remove the filter FDT FDTC

Hook of soft material helps to remove the filter without dust spreading.

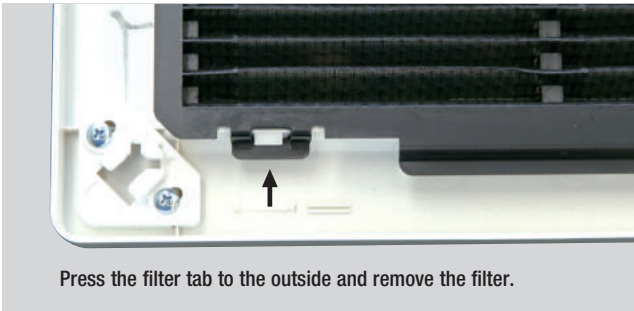

### 2 Securely fix the corner lid by strap FDT

The direction of the strap hook part has been changed from longitudinal to lateral. Furthermore, a barb has been added to the hook pin to prevent the strap from coming off.



### 3 Drain-up-lift increases up to 850 mm FDT FDTC

The drain can be lifted up to 850 mm from the ceiling surface.

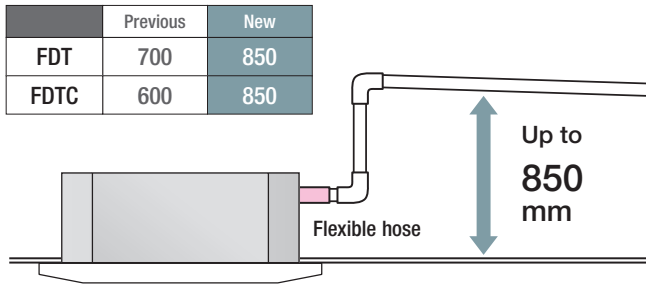

### 4 New port to check drain water flow FDT

A water supply port has been provided in the piping lid for easier testing of the drain water flow. (The port is usually sealed with a rubber cap.)

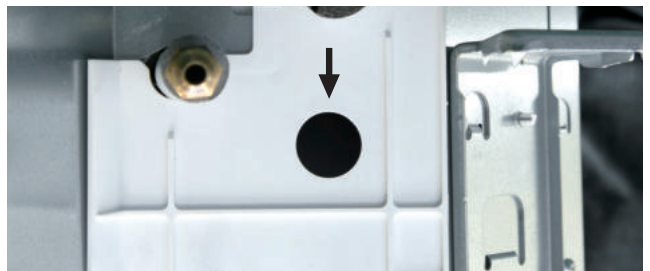

### 5 Re-use of packages during construction work FDT FDTC

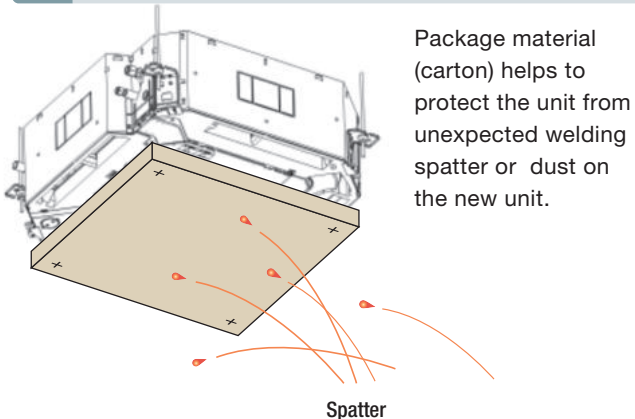

### 6 More flexible outlet for ducting FDT FDTC

Both  $\Phi 125$  and  $\Phi 200$  (oval shaped) are available.

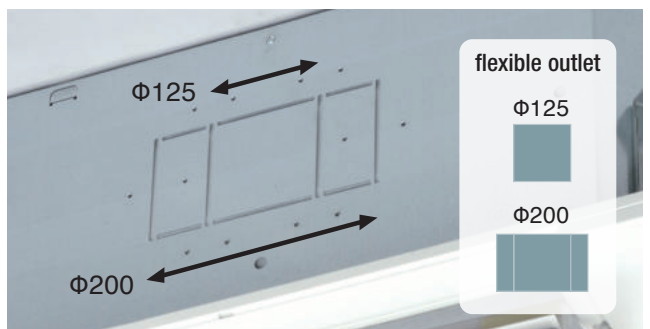

# Remote Control

Simple use with advanced settings REMOTE CONTROL

## RC-EX3D

Intuitive touch controller with Liquid Crystal Display

### Function Switch

The function switch allows you to select and set two functions of your choice among the seven available functions shown. These functions can be used by simply pressing the button after they are set, allowing you to use your preferable functions immediately.



#### 1. Draft prevention ON/OFF



Anti draft can be turned ON/OFF with a single tap of the button.

#### 2. High Power Mode



High Power Mode achieve excessive cooling / heating capacity in 15 minutes to quickly adjust the room temperature to a comfortable level.

#### 3. Energy Saving Mode



Temperature is set to be optimized to save energy without losing comfort.

#### 4. Quiet Mode



Outdoor unit starts to operate quietly by activating this mode. The time of this mode can be set in conjunction with Indoor Silent Timer.

#### 5. Home Leave Mode



Home leave mode maintains the room temperature at a moderate level.

#### 6. Favourite Mode



Operation mode, set temperature, fan speed and air flow direction will automatically be adjusted to the programmed favourite setting.

#### 7. Filter Sign



Announces the due time for cleaning the air filter.

### Favourite Mode

Operation mode, set temperature, fan speed and air flow direction are memorized and allocated to two buttons that can be operated by one touch.

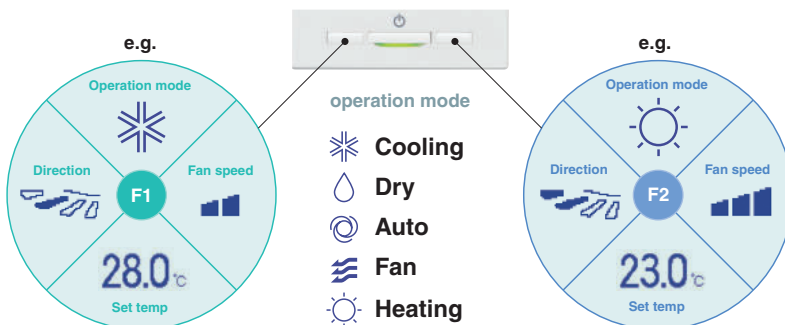

### Adjustable Brightness of the Operation Lamp

The brightness of the operation lamp behind Run/Stop switch can be adjusted by 10 stages.



## Draft Prevention Setting (only for FDT•FDTC series)

User can enable/disable the motion of Draft prevention panel for each blow outlet for each operation mode. This function can be set while operating.

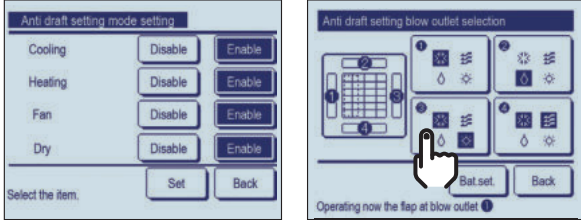

## Easy Adjustment of the Air Flow

User can visually confirm and set the direction of flaps using the visual display on the remote controller.

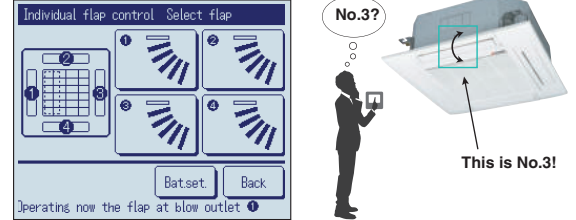

## Motion Sensor Control

Presence of humans and activity are detected by a motion sensor to perform various controls.

### 1 Select Enable / Disable Motion sensor control



Enable/Disable

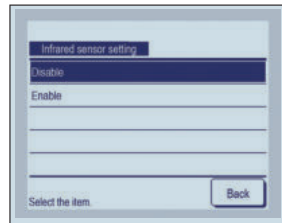

Select **Enable**/**Disable** for the motion sensor of the indoor unit connected to the R/C.

### 2 Select Enable / Disable per control

- Power control
- Auto-off

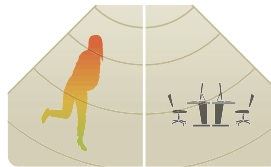

Enable/Disable

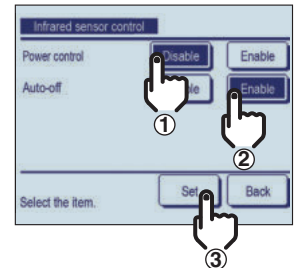

## Backup Control

Control restricted to two indoor units (two groups)



### Fault backup control

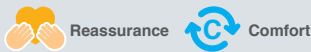

#### Keep back up all the time!

If one of the two indoor units malfunctions and stops its operation, the other starts backup operation so that users' comfort will not be compromised.

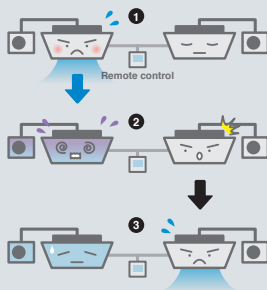

### Capacity backup control



#### Maintains users' comfort!

When the control system detects either of its two units operating with overload, the other unit cover the capacity.

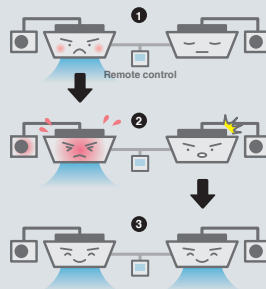

### Rotational operation control



#### Energy saving and longer life!

By operating two indoor units alternately, their chronological changes are equalized. (The alternate operation cycle can be specified in a range from 1 to 999 hours in increments of 1 hours.)

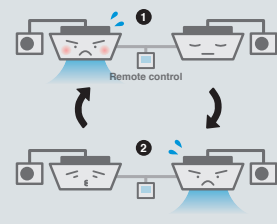

New

# Stylish Remote Control

## 2025 Design Award



reddot winner 2025

The RC-ES1 Series has been honored with the prestigious Red Dot Design Award 2025 in the Product Design Category.



The RC-ES1 Series has been honored with the prestigious Gold A' Design Award in the Repair, Restoration, and Maintenance Products Design Category.



## RC-ES1

- Stylish and sophisticated design
- Compact size (86×86mm)
- Remote control with Bluetooth® wireless technology



## Optimized User Interface



The functions available on the remote have been minimized to focus on users' core needs, simplifying operation and avoiding overly complex settings. A wide range of functions, including service settings, remains accessible through the app.



You can control the air-conditioner by installing App on your smart phone



Search for "M-Air PRO" from the Google Play™ store for Android™ and App Store for iPhone.

Please check the app stores for the latest supported OS version information. App Store and iPhone are registered trademarks of Apple Inc. Google Play and the Google Play logo are trademarks of Google LLC.

## Wireless connection

- Remote control with Bluetooth® wireless technology
- Easy set-up of indoor units
- Notifications of abnormal conditions or operational data from the remote control will be sent to your smartphone.



## Information screen

By looking at the information screen, you can check the current operating conditions at a glance.



## Central management by smart phone

You can select and change the settings of multiple rooms with only one action on your smartphone.\*

Easy setup and management of up to 20 units via smartphone and tablets, up to 10 settings could be saved in the app.

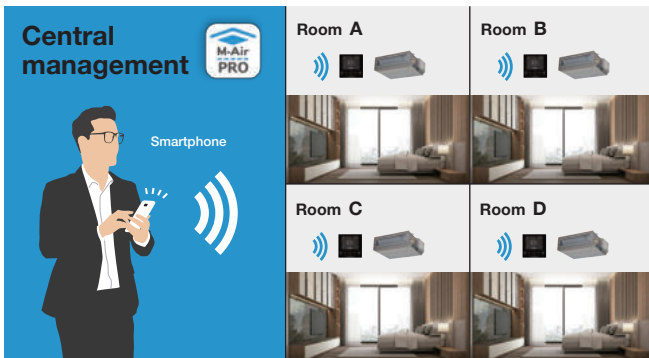

\*The function would be available when the smartphone is connected to the remote control with Bluetooth® wireless technology.

## Easy installation with the new casing structure

The casing is separated into the lower and the upper case.

By inserting the upper case into the lower case embedded to the wall, the remote could be easily installed.

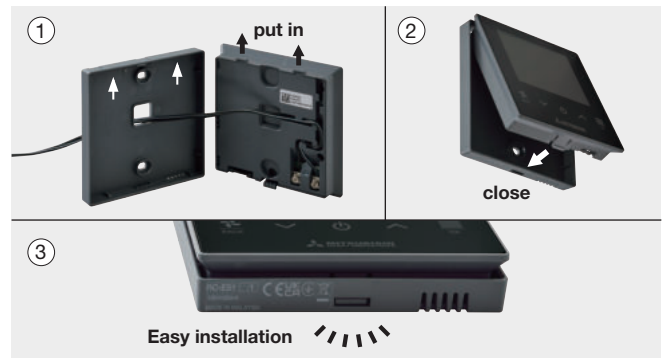

## Easy to instinctively operate with simplified icons

Operation settings	Common settings	Display & sound settings
<p><b>MODE</b> <b>Operation mode</b> Heating / Cooling / Fan / Dry / Auto</p> <p><b>High power</b> ON / OFF</p> <p><b>Ventilation</b> ON / OFF</p> <p><b>Timer</b> Set ON / OFF timer by hour Set ON / OFF timer by clock</p> <p><b>Air direction</b> Upper / lower flap, Flap direction</p>	<p><b>Bluetooth</b> ON / OFF</p> <p><b>Pairing mode</b> Make a new Bluetooth pairing</p> <p><b>App QR code</b> QR code for the app</p>	<p><b>Brightness</b> 1-10</p> <p><b>Lighting time</b> 1-10</p> <p><b>Operation sound</b> Sound On / Sound Off</p>
Information screen		
<p><b>Temporary stop</b></p> <p><b>Thermo-off</b></p> <p><b>Fan operation</b></p> <p><b>Cooling test run</b></p> <p><b>Static pressure adjustment</b></p> <p><b>Dew drop prevention control</b></p> <p><b>Home leave operation</b></p>	<p><b>High power operation</b></p> <p><b>Eco operation</b></p> <p><b>Set temp. shift</b></p> <p><b>Warm up operation</b></p> <p><b>Heating preparation</b></p> <p><b>Defrost operation</b></p> <p><b>Outdoor silent operation</b></p>	<p><b>Motion sensor control</b></p> <p><b>Anti draft control</b></p> <p><b>Demand control</b></p> <p><b>Filter cleaning time</b></p> <p><b>Back-up control in operation</b></p> <p><b>Fault back-up control in operation</b></p> <p><b>Periodical check indication</b></p> <p><b>On timer setting</b></p> <p><b>OFF timer setting</b></p> <p><b>Weekly timer setting</b></p> <p><b>Sleep timer setting</b></p>

The Bluetooth® word mark and logos are registered trademarks owned by Bluetooth SIG, Inc. and any use of such marks by MITSUBISHI HEAVY INDUSTRIES THERMAL SYSTEMS, LTD. is under license.

Other trademarks and trade names are those of their respective owners.

"QR Code" is a registered trademark of DENSO WAVE INCORPORATED.





# Indoor unit benefits Summary

## Benefits Series



When using RC-EX3D (Remote control), functions with symbol ● are available.

However, for RC-E5 (Remote control), functions with ★ are not available.

<b>Energy Saving</b> 	<b>Inverter technology</b>	Inverter control technology delivers high efficiency and a smooth operation from high speed to low speed. A smooth sine voltage wave is attained.	
	<b>Energy-saving</b> ★	Since the capacity is controlled automatically based on the outdoor temperature, energy can be saved without losing comfort.	
	<b>Motion sensor</b> ★	This sensor detects human activity and shifts the temperature setting according to the amount of activity in the room.	
	<b>Home leave operation</b> ★	This function ensures that when the room is unoccupied for long periods of time, the unit will maintain a moderate indoor temperature, avoiding extremely hot or cool temperatures.	
	<b>Set temperature auto return</b> ★	This function allows the user to program a preferred set temperature that the unit will return to each time it is operated.	
<b>Comfort</b> 	<b>Automatic operation</b>	This function automatically selects the required heating or cooling function based on the current room conditions.	
	<b>Silent operation</b>	This function allows the user to program periods where the unit will operate with reduced noise levels, perfect for night time and an uninterrupted sleep.	
	<b>Hi power operation</b> ★	Use the high power function to quickly reach your optimum temperature level when you first turn on the unit. This function will operate for a maximum of 15 minutes before returning to normal operation.	
<b>Air flow</b> 	<b>Flap control system</b>	This function allows the user to set the upper and lower limit positions of the flap at each air outlet individually, providing you with complete control over interior air flow.	
	<b>Vertical auto swing</b>	The vertical louvers on your unit will move up and down continuously during operation. This function allows you to set the up/down swing position of the louver to the preferred operation angle.	
	<b>Draft prevention setting</b> ★	Draft Prevention setting provides a comfortable air flow without any draft feeling. Whether cooling or heating a room, the remote control can be used to instantly suppress any warm or cool drafts. This accurately assists how air flow is directed out of the indoor unit.	
	<b>Automatic fan speed</b>	The unit's on-board microcomputer continuously monitors the room's air temperature and adjusts the air flow automatically.	
<b>Timer</b> 	<b>Sleep timer</b>	This function allows the user to set a pre-determined amount of time between 30 and 240 minutes that your unit will operate for before switching off.	
	<b>Peak-cut timer</b> ★	This function lets the user to preset the capacity limit during certain periods of the day, minimising energy consumption during peak billing times, thus reducing operation costs.	
	<b>Weekly timer</b>	Set the unit to turn on and off automatically on a weekly basis to suit your usual room usage on each day.	
<b>Convenient</b> 	<b>Function Switch</b> ★	From the eight available functions on the unit, this function allows the user to set two functions to operate automatically.	
	<b>Favourite setting</b> ★	Operation mode, set temperature, fan speed and air flow direction automatically adjust to the programmed favourite setting.	
	<b>Static pressure adjustment</b>	This is operable when connecting duct type indoor units equipped with the external static pressure adjustment function. It will adjust the air flow accordingly based on the connected duct static pressure.	
	<b>Select the language</b> ★	Set the language to be displayed on the remote control.	
	<b>Air filter</b>	The air filter in the unit traps and removes airborne dust particles and other allergens to provide you clean air.	
	<b>Filter sign</b>	This warning alerts when the filter needs to be cleaned.	
	<b>Outside air intake</b>	This function provides clean fresh air into the room through the external air intake, avoiding the constant recycling of internal air.	
<b>Others</b>	<b>Self diagnostics</b>	The internal microcomputer automatically runs a diagnostic of the system in the event of a malfunction. This enables authorised dealers to isolate and repair any issues.	
	<b>Built in drain pump</b>	The built-in drain pump, allows greater flexibility with installation, offering a great solution for applications with limited space.	
	<b>Improved serviceability</b>	The fan unit (comprised of impeller and motor) is easily accessible from either the side or bottom of the unit and can be slid out for easy maintenance.	



# Ceiling Cassette -4way- FDT **New**



FDT28-160



Black Panel



Draft Prevention Panel  
(Option)

## Remote control (Option)

Wired



RC-EX3D



RC-E5



RC-ES1

Wireless



RCN-T-5BW-E2(White)



RCN-T-5BB-E2(Black)



## R32 Leak detector and shut-off valve available as an option

Refrigerant leak detector  
RLD-KIT-E

Shut-off valve  
SV-KIT-S1N-E  
SV-KIT-L1N-E



\*R32 indoor unit are not compatible with R410A outdoor unit and vice versa.

Panel select pattern			(Option)			
		Receiver	Sensor		Receiver	Interface
			Thermal sensor kit LC-T-5CW(B)-E	Motion sensor kit LB-T-5BW(B)-E	Wireless receiver kit RCN-T-5BW(B)-E2	Wireless LAN interface WF-PAC-E
KXZE3-W	Standard Panel	T-PSA-5CW(B)-E	●	●	●	●
	Draft Prevention Panel	T-PSAE-5CW(B)-E	●	●	●	●
KXZE1	Standard Panel	T-PSA-5BW(B)-E	—	●	●	—
	Draft Prevention Panel	T-PSAE-5BW(B)-E	—	●	●	—

## Automatic anti-draft control

(Option)

### Thermal sensor kit

LC-T-5CW-E  
LC-T-5CB-E

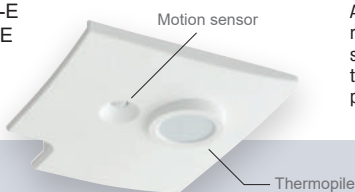

### 1. Automatic anti-draft control

Automatically activates the louvers when the room temperature is hotter or colder than the set temperature. After detecting the room temperature at the set temperature, the draft prevention panel is activated.

### 2. Direct flow control

The louvers are controlled to blow towards human position.

### 3. Draft less control

Draft prevention panel is activated based on human position

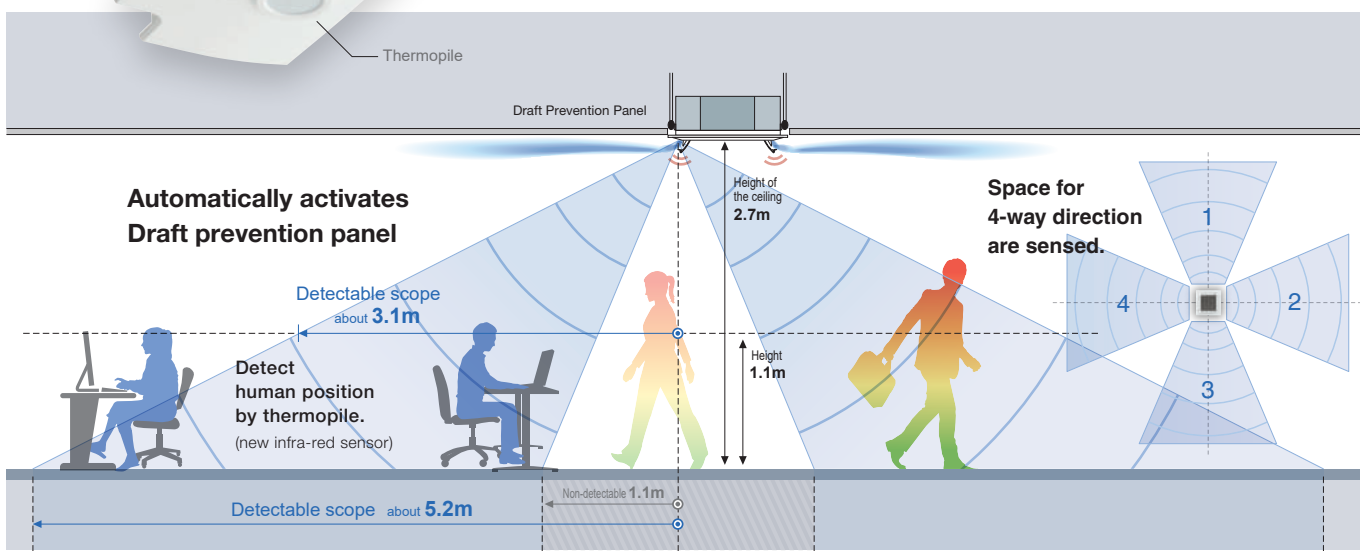

### Draft Prevention Panel

(Option)



This prevents cold/hot draft being blown directly on the user. It is possible to set Draft Prevention Panel for each air outlet.

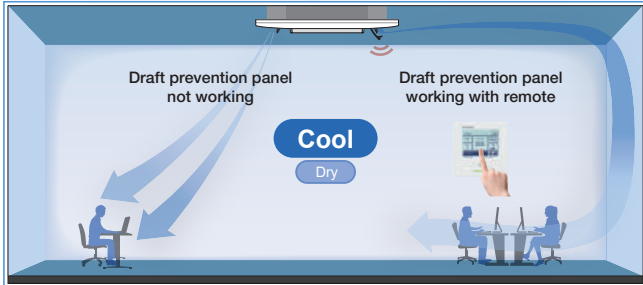

User can position panels by using the remote controller (RC-EX3D, Wireless kit) only when Draft Prevention Panel is available.

### Motion Sensor

(Option)

Motion sensor is equipped in the corner of the panel and detects the presence/absence and activity of humans in a room to improve the comfort and energy saving performance of the unit.

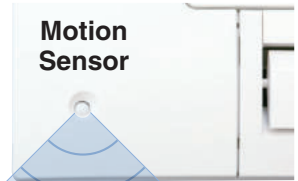

LB-T-5BW-E(White)  
LB-T-5BB-E(Black)

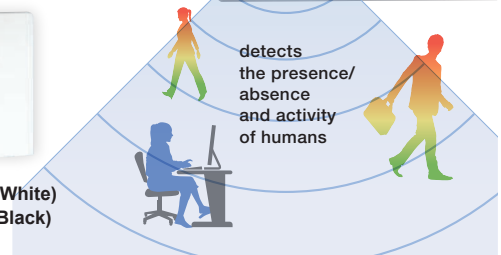

### Individual flap control system

According to room conditions, four directions of air flow can be controlled individually by utilizing the flap control system. Individual flap control is available even after installation.

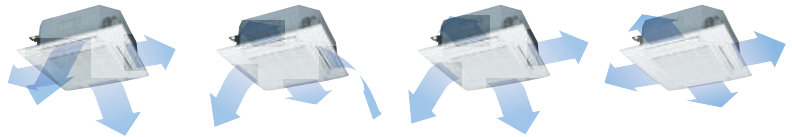

Flap can swing within an upper and lower flap range that can be selected with a wired remote control.

\* The wireless remote control is not applicable to the Individual flap control system.

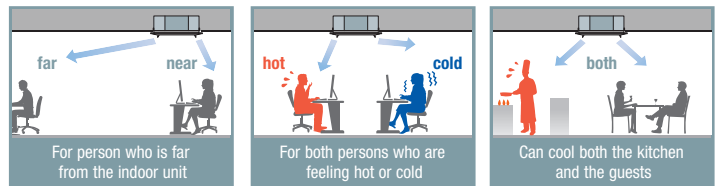
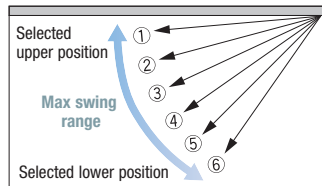

### Power consumption decreased by new technologies

1. Adopting new impeller and flow path.

#### New designed impeller

improves the aerodynamic performance of the unit.

New designed component has better aerodynamic performance and achieve lower noise.



2.  $\Phi 5.0$  heat exchanger tubes is adopted to improve the performance.

#### Slimmer heat exchanger and a dense copper piping.

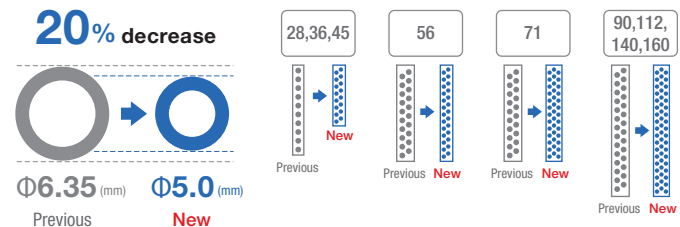

### Wireless Control System Now available in our FDT series

Control your air-conditioner from anywhere, anytime. If you turn on the air-conditioner when you're on the go, you'll be comfortable when you get to the office. Even if you forget to turn it off, you can turn it off when you are out.



### 850mm Drain Pump

Drain can be discharged upwards up to 850mm from the ceiling surface, allowing a piping layout with a high degree of freedom. Thanks to the 185mm flexible hose, equipment supports easy workability.

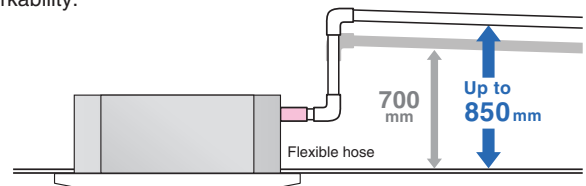

## ■ SPECIFICATIONS

Indoor unit	FDT		28KXZE3-W	36KXZE3-W	45KXZE3-W	56KXZE3-W	71KXZE3-W	90KXZE3-W	112KXZE3-W	140KXZE3-W	160KXZE3-W	
Power source	1 Phase 220-240V, 50Hz											
Nominal capacity	Cooling	kW	2.8	3.6	4.5	5.6	7.1	9.0	11.2	14.0	16.0	
	Heating		3.2	4.0	5.0	6.3	8.0	10.0	12.5	16.0	18.0	
Power consumption	Cooling	W	40-40			70-70	80-80	130-130				
	Heating											
Sound power level <sup>1</sup>	Cooling	dB(A)	55			60	62	65				
	Heating											
Sound pressure level <sup>1</sup> (P-Hi/Hi/Me/Lo)	Cooling	dB(A)	40/31/30/28	40/34/30/28	40/34/31/28	45/34/31/29	47/35/32/28	49/38/36/31	49/39/37/31	49/42/39/32	49/42/40/33	
	Heating		40/31/26/23	40/33/26/23	40/33/30/23							
Exterior dimensions (H × W × D)	Unit	mm	236 × 840 × 840					298 × 840 × 840				
	Panel		35 × 950 × 950					35 × 950 × 950				
Net weight	Unit	kg	21		22	24	28					
	Panel		Standard panel : 5, Draft prevention panel : 6									
Air flow (P-Hi/Hi/Me/Lo)	Cooling	m <sup>3</sup> / min	19/12/10/9	19/14/10/9	19/14/12/9	25/15/13/11	28/16/14/12	37/24/21/16	37/24/22/16	37/27/24/17	37/28/25/18	
	Heating											
Outside air intake	Possible											
Refrigerant Type	R32											
Refrigerant piping size (Flare)	Liquid	mm (in)	ø6.35(1/4")				ø9.52(3/8")					
	Gas		ø9.52(3/8")	ø12.7(1/2")			ø15.88(5/8")					
Panel (Option)	White : T-PSA-5CW-E, T-PSAE-5CW-E Black : T-PSA-5CB-E, T-PSAE-5CB-E											
Air filter, Q'ty	Pocket plastic net × 1(Washable)											

Indoor unit	FDT		28KXZE1	36KXZE1	45KXZE1	56KXZE1	71KXZE1	90KXZE1	112KXZE1	140KXZE1	160KXZE1	
Power source	1 Phase 220-240V, 50Hz											
Nominal capacity	Cooling	kW	2.8	3.6	4.5	5.6	7.1	9.0	11.2	14.0	16.0	
	Heating		3.2	4.0	5.0	6.3	8.0	10.0	12.5	16.0	18.0	
Power consumption	Cooling	W	40-40			70-70	80-80	130-130	140-140			
	Heating											
Sound power level <sup>1</sup>	Cooling	dB(A)	55			60	62	65	66			
	Heating											
Sound pressure level <sup>1</sup> (P-Hi/Hi/Me/Lo)	Cooling	dB(A)	38/33/30/28		38/33/31/29	44/33/31/29	47/35/32/28	49/38/36/31	49/39/37/31	49/42/39/32	49/42/39/33	
	Heating											
Exterior dimensions (H × W × D)	Unit	mm	236 × 840 × 840					298 × 840 × 840				
	Panel		35 × 950 × 950					35 × 950 × 950				
Net weight	Unit	kg	20		21.5			25				
	Panel		Standard panel : 5, Draft prevention panel : 6									
Air flow (P-Hi/Hi/Me/Lo)	Cooling	m <sup>3</sup> / min	20/14/12/10	20/14/12/10	20/15/13/10	26/16/13/11	28/17/14/12	37/25/22/15	38/26/23/17	38/28/25/18	38/29/26/19	
	Heating											
Outside air intake	Possible											
Refrigerant Type	R410A											
Refrigerant piping size (Flare)	Liquid	mm (in)	ø6.35(1/4")				ø9.52(3/8")					
	Gas		ø9.52(3/8")	ø12.7(1/2")			ø15.88(5/8")					
Panel (Option)	White : T-PSA-5BW-E, T-PSAE-5BW-E Black : T-PSA-5BB-E, T-PSAE-5BB-E											
Air filter, Q'ty	Pocket plastic net × 1(Washable)											

1. The data are measured under the following conditions(ISO-T1). Cooling: Indoor temp. of 27°CDB, 19°CWB, and outdoor temp. of 35°CDB. Heating: Indoor temp. of 20°CDB, and outdoor temp. of 7°CDB, 6°CWB.  
2. Sound pressure level indicates the value in an anechoic chamber. During operation these values are somewhat higher due to ambient conditions



# Ceiling Cassette - 4way Compact FDTC



**New**



FDTC15-56

Honeycomb type



Draft Prevention  
Panel (Option)



Grid type

## Remote control (Option)

Wired



RC-EX3D



RC-E5



RC-ES1

Wireless



RCN-TC-5AW-E3

## R32 Leak detector and shut-off valve available as an option

Refrigerant  
leak detector  
RLD-KIT-E



Shut-off valve  
SV-KIT-S1N-E  
SV-KIT-L1N-E



\*R32 indoor unit are not compatible with R410A outdoor unit and vice versa.

## Panel select pattern

(Option)

		Motion sensor	Wireless receiver	Motion sensor & Wireless receiver	
		 LB-TC-5W-E	 RCN-TC-5AW-E3	 LB-TC-5W-E	 RCN-TC-5AW-E3
 Honeycomb type	Standard Panel	TC-PSA-5AW-E	●	●	●
	Draft Prevention Panel	TC-PSAE-5AW-E	●	●	●
 Grid type	Standard Panel	TC-PSAG-5AW-E	●	●	●
	Draft Prevention Panel	TC-PSAGE-5AW-E	●	●	●

## European design & Flat panel

### Unique Grille Design

A grille designed with a unique structure and a clean white panel that blends with the room.

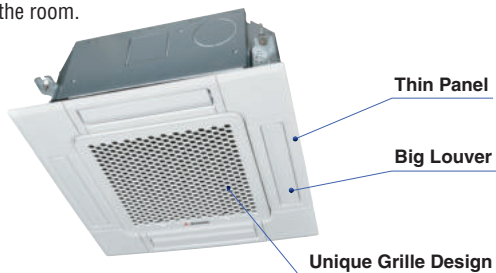

### Integrated ceiling system design 600x600

The weight is 14kg Height of thin panel and main body is 248mm allowing adequate spacing for installation.



## Draft Prevention Panel

This prevents cold/hot draft being blown directly on the user. It is possible to set Draft Prevention Panel for each air outlet.

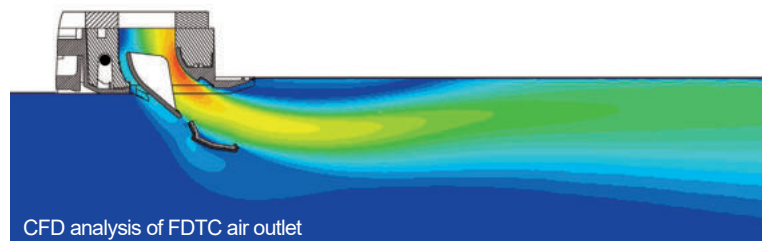
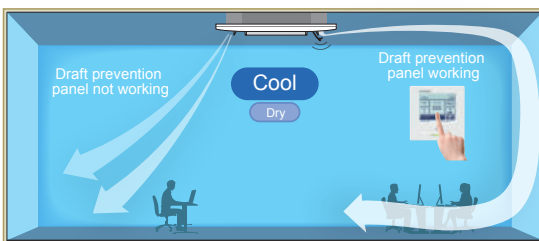

User can position panels by using the remote controller (RC-EX3D, Wireless kit) only when Draft Prevention Panel is available.

### Individual flap control system

According to room temperature conditions, four directions of air flow can be controlled individually by following Flap control system. Individual flap control is available even after installation.



The flap can swing within the range of upper and lower flap position selected with wired remote control.

\*The wireless remote control is not applicable to the Individual flap control system.

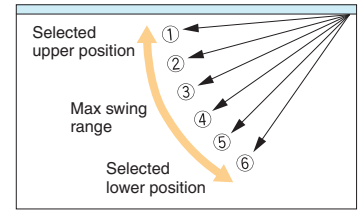

### Motion Sensor

(Option)

Motion sensor is equipped in the corner of the panel and detects the presence/absence and activity of humans in a room to improve the comfort and energy saving performance of the unit.



LB-TC-5W-E

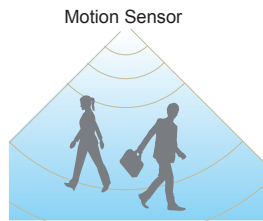

### Suitable for High ceilings

The Powerful blowout carries comfortable air flow to the floor even in high ceiling applications. It is ideal for high ceiling offices, stores, etc., with a wide, uniform air flow throughout the room.

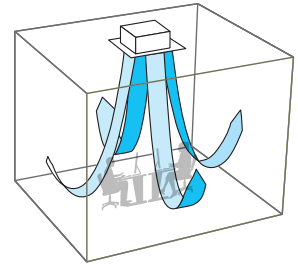

### 850mm Drain Pump

Drain can be discharged upward by 850 mm from the ceiling surface close to the indoor unit. It allows a piping layout with a high degree of freedom depending on the installation location.

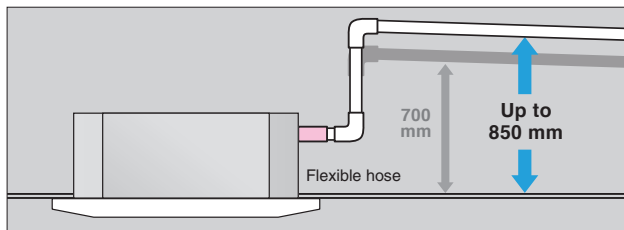

### Taking OA (Outside Air) into inside

Fresh air can be taken in without optional parts. When the fresh air is insufficient, optional parts can be used.

OA Spacer TC-OAS-E2 (Option)  
Joint Duct TC-OAD-E (Option)

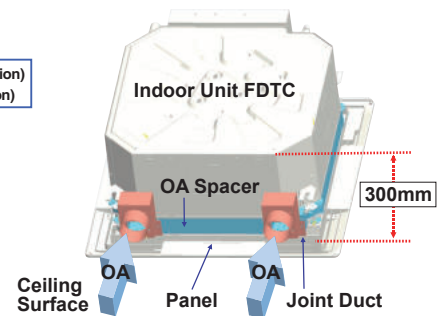

## SPECIFICATIONS

Indoor unit	FDTC		15KXZE3-W	22KXZE3-W	28KXZE3-W	36KXZE3-W	45KXZE3-W	56KXZE3-W
Power source	1 Phase 220-240V, 50Hz							
Nominal capacity	Cooling	kW	1.5	2.2	2.8	3.6	4.5	5.6
	Heating		1.7	2.5	3.2	4.0	5.0	6.3
Power consumption	Cooling	W	30-30			40-40	50-50	60-60
	Heating		30-30			40-40	50-50	60-60
Sound power level <sup>1</sup>	Cooling	dB(A)	47	49		54	58	60
	Heating		46	49		53	57	
Sound pressure level <sup>1</sup> (P-Hi/Hi/Me/Lo)	Cooling	dB(A)	33/30/28/25	35/32/29/25		39/36/31/26	43/39/36/28	47/43/39/31
	Heating		33/30/26/22	35/32/29/25		39/36/31/26	43/39/36/28	
Exterior dimensions (H × W × D)	Unit	mm	248 × 570 × 570					
	Panel		10 × 620 × 620					
Net weight	Unit	kg	12.5	13		14		
	Panel		Standard panel : 2.5, Draft prevention panel : 3					
Air flow (P-Hi/Hi/Me/Lo)	Cooling	m <sup>3</sup> / min	8/7/6/5	9/8/7/6		10/9/8/6	12/10/9/7	14/12/10/8
	Heating		8/7/6/5	9/8/7/6		10/9/8/6	12/10/9/7	14/12/10/8
Outside air intake	Possible							
Refrigerant Type	R32							
Refrigerant piping size (Flare)	Liquid	mm (in)	ø6.35(1/4")					
	Gas		ø9.52(3/8")			ø12.7(1/2")		
Panel (Option)	Honeycomb : TC-PSA-5AW-E, TC-PSAE-5AW-E Grid : TC-PSAG-5AW-E, TC-PSAGE-5AW-E							
Air filter, Q'ty	Pocket plastic net × 1(Washable)							

Indoor unit	FDTC		15KXZE1	22KXZE1	28KXZE1	36KXZE1	45KXZE1	56KXZE1
Power source	1 Phase 220-240V, 50Hz							
Nominal capacity	Cooling	kW	1.5	2.2	2.8	3.6	4.5	5.6
	Heating		1.7	2.5	3.2	4.0	5.0	6.3
Power consumption	Cooling	W	30-30			40-40	50-50	60-60
	Heating		30-30			40-40	50-50	60-60
Sound power level <sup>1</sup>	Cooling	dB(A)	47	49		54	58	60
	Heating		46	49		53	57	
Sound pressure level <sup>1</sup> (P-Hi/Hi/Me/Lo)	Cooling	dB(A)	33/30/28/25	35/32/29/25		39/36/31/26	43/39/36/28	47/43/39/31
	Heating		33/30/26/22	35/32/29/25		39/36/31/26	43/39/36/28	
Exterior dimensions (H × W × D)	Unit	mm	248 × 570 × 570					
	Panel		10 × 620 × 620					
Net weight	Unit	kg	12.5	13		14		
	Panel		Standard panel : 2.5, Draft prevention panel : 3					
Air flow (P-Hi/Hi/Me/Lo)	Cooling	m <sup>3</sup> / min	8/7/6/5	9/8/7/6		10/9/8/6	12/10/9/7	14/12/10/8
	Heating		8/7/6/5	9/8/7/6		10/9/8/6	12/10/9/7	14/12/10/8
Outside air intake	Possible							
Refrigerant Type	R410A							
Refrigerant piping size (Flare)	Liquid	mm (in)	ø6.35(1/4")					
	Gas		ø9.52(3/8")			ø12.7(1/2")		
Panel (Option)	Honeycomb : TC-PSA-5AW-E, TC-PSAE-5AW-E Grid : TC-PSAG-5AW-E, TC-PSAGE-5AW-E							
Air filter, Q'ty	Pocket plastic net × 1(Washable)							

- The data are measured under the following conditions(ISO-T1). Cooling: Indoor temp. of 27°CDB, 19°CWB, and outdoor temp. of 35°CDB. Heating: Indoor temp. of 20°CDB, and outdoor temp. of 7°CDB, 6°CWB.
- Sound pressure level indicates the value in an anechoic chamber. During operation these values are somewhat higher due to ambient conditions.



# Ceiling Cassette -2way- FDTW



FDTW28-71

New



FDTW90-140

\*R32 indoor unit are not compatible with R410A outdoor unit and vice versa.

## Remote control (Option)

Wired



RC-EX3D



RC-E5



RC-ES1

Wireless



RCN-TW-E2

## R32 Leak detector and shut-off valve available as an option

Refrigerant leak detector  
RLD-KIT-E



Shut-off valve  
SV-KIT-S1N-E  
SV-KIT-L1N-E



### Individual flap control system

We've optimised our outlet design with advanced technology to allow you to control up to four directions of air flow. Allowing you to control air direction via the flap systems and room temperature.

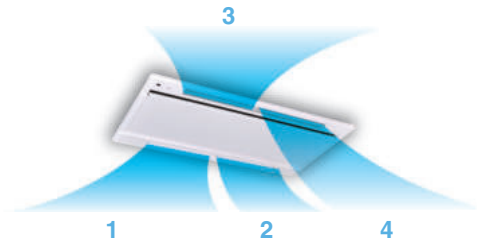

The flap can swing within the range of upper and lower flap position selected with wired control.

\*The wireless remote control is not applicable with the individual flap control system.

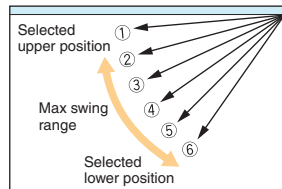

### Motion Sensor

(Option)

Motion sensor is equipped in the corner of the panel and detects the presence/absence and activity of humans in a room to improve the comfort and energy saving performance of the unit.

LB-TW-6W

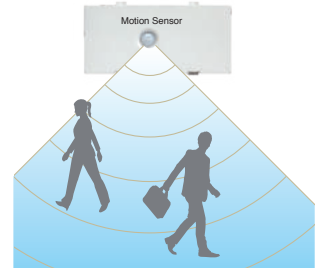

### Installation workability

Drainage flow test can be done easily by use of this drainage spout.

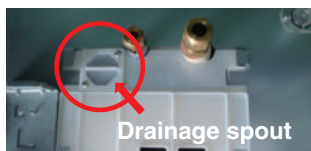

Condition of the bottom of a drain pan can be checked through this transparent access hole without removing drain pan.

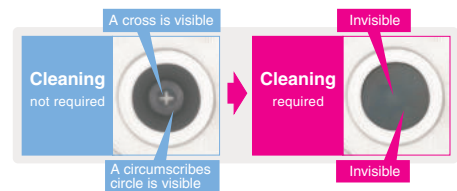

### Transparent access hole to drain pan

### 850mm Drain Pump

The drain discharge system allows for a piping layout with a high degree of freedom (dependent on installation location). Discharge from above 850mm from a ceiling surface to the indoor unit.

## SPECIFICATIONS

Indoor unit	FDTW		28KXZE3-W	45KXZE3-W	56KXZE3-W	71KXZE3-W	90KXZE3-W	112KXZE3-W	140KXZE3-W	
Power source			1 Phase 220-240V, 50Hz							
Nominal capacity	Cooling	kW	2.8	4.5	5.6	7.1	9.0	11.2	14.0	
	Heating		3.2	5.0	6.3	8.0	10.0	12.5	16.0	
Power consumption	Cooling	W	90-90	100-100		140-140		190-190		
	Heating									
Sound power level <sup>1</sup>	Cooling	dB(A)	57	58			63			
	Heating									62
Sound pressure level <sup>1</sup> (P-Hi/Hi/Me/Lo)	Cooling	dB(A)	42/38/34/31				48/45/41/37			
	Heating									
Exterior dimensions (H × W × D)	Unit	mm	325 × 820 × 620				325 × 1535 × 620			
	Panel		20 × 1120 × 680				20×1835×680			
Net weight	Unit	kg	20	21		23		35		
	Panel		8.5	8.5		8.5		13		
Air flow (P-Hi/Hi/Me/Lo)	Cooling	m <sup>3</sup> / min	14.5/12/10/9				31/27/23/20			
	Heating									
Outside air intake			Possible							
Refrigerant Type			R32							
Refrigerant piping size (Flare)	Liquid	mm (in)	ø6.35(1/4")			ø9.52(3/8")				
	Gas		ø9.52(3/8")	ø12.7(1/2")		ø15.88(5/8")				
Panel (Option)			TW-PSA-26W-E				TW-PSA-46W-E			
Air filter, Q'ty			Pocket plastic net × 2 (Washable)				Pocket plastic net × 3 (Washable)			

Indoor unit	FDTW		28KXE6F	45KXE6F	56KXE6F	71KXE6F	90KXE6F	112KXE6F	140KXE6F	
Power source			1 Phase 220-240V, 50Hz							
Nominal capacity	Cooling	kW	2.8	4.5	5.6	7.1	9.0	11.2	14.0	
	Heating		3.2	5.0	6.3	8.0	10.0	12.5	16.0	
Power consumption	Cooling	W	90-90	100-100		140-140		190-190		
	Heating									
Sound power level <sup>1</sup>	Cooling	dB(A)	58			65				
	Heating									
Sound pressure level <sup>1</sup> (P-Hi/Hi/Me/Lo)	Cooling	dB(A)	42/38/34/31				48/45/41/37			
	Heating									
Exterior dimensions (H × W × D)	Unit	mm	325 × 820 × 620				325 × 1535 × 620			
	Panel		20 × 1120 × 680				20 × 1835 × 680			
Net weight	Unit	kg	20	21		23		35		
	Panel		8.5	8.5		8.5		13		
Air flow (P-Hi/Hi/Me/Lo)	Cooling	m <sup>3</sup> / min	14.5/12/10/9				31/27/23/20			
	Heating									
Outside air intake			Possible							
Refrigerant Type			R410A							
Refrigerant piping size (Flare)	Liquid	mm (in)	ø6.35(1/4")			ø9.52(3/8")				
	Gas		ø9.52(3/8")	ø12.7(1/2")		ø15.88(5/8")				
Panel (Option)			TW-PSA-26W-E				TW-PSA-46W-E			
Air filter, Q'ty			Pocket plastic net × 2(Washable)				Pocket plastic net × 3(Washable)			

- The data are measured under the following conditions(ISO-T1). Cooling: Indoor temp. of 27°CDB, 19°CWB, and outdoor temp. of 35°CDB. Heating: Indoor temp. of 20°CDB, and outdoor temp. of 7°CDB, 6°CWB.
- Sound pressure level indicates the value in an anechoic chamber. During operation these values are somewhat higher due to ambient conditions.

# Ceiling Cassette -1way- FDTS



**New**



**FDTS45 · 71**

\*R32 indoor unit are not compatible with R410A outdoor unit and vice versa.

## Individual flap control system

Two directions of air flow can be controlled individually by flap control system.



The flap can swing within the range of upper and lower flap position selected with wired control.

\*The wireless remote control is not applicable with the individual flap control system.

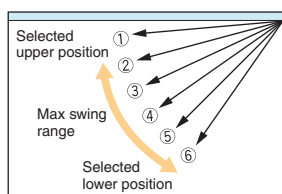

## Compact design

Indoor unit size (W:1150 x D:565) brings easy installation for 1200 x 600 ceiling and Panel size (1250 x 650) is suitable for 1200 x 600 ceiling. Height is the industry's lowest height level 220mm and weight is only 27, 28kg.

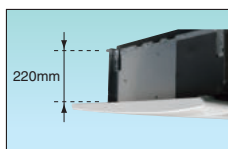

## Remote control (Option)

Wired



**RC-EX3D**



**RC-E5**

Wireless



**RC-ES1**



**RCN-TS-E2**

## R32 Leak detector and shut-off valve available as an option

Refrigerant leak detector  
RLD-KIT-E



Shut-off valve  
SV-KIT-S1N-E  
SV-KIT-L1N-E



## Motion Sensor

(Option)

Motion sensor is equipped in the ceiling plane or wall plane and detects the presence/absence and activity of humans in a room to improve the comfort and energy saving performance of the unit.



**LB-KIT2**

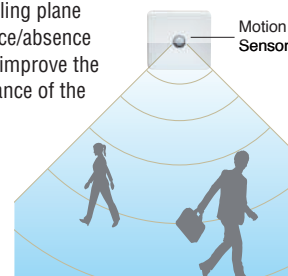

## 850mm Drain Pump

Drain can be discharged upward by 850mm from the ceiling surface close to the indoor unit. It allows a piping layout with a high degree of freedom depending on the installation location.

## SPECIFICATIONS

Indoor unit		FDTS	45KXZE3-W	71KXZE3-W	45KXE6F	71KXE6F
Power source			1 Phase 220-240V, 50Hz			
Nominal capacity	Cooling	kW	4.5	7.1	4.5	7.1
	Heating		5.0	8.0	5.0	8.0
Power consumption	Cooling	W	40-40	90-90	40-40	90-90
	Heating					
Sound power level <sup>1</sup>	Cooling	dB(A)	52	60	60	61
	Heating					
Sound pressure level <sup>1</sup> (P-Hi/Hi/Me/Lo)	Cooling	dB(A)	40/39/37/35	49/46/41/36	42/40/38/35	49/46/41/36
	Heating					
Exterior dimensions (H x W x D)	Unit	mm	220 x 1150 x 565			
	Panel		35 x 1250 x 650			
Net weight	Unit	kg	27	28	27	28
	Panel		5	5	5	5
Air flow (P-Hi/Hi/Me/Lo)	Cooling	m <sup>3</sup> /min	13/12/11/9.5	17/15/12/10	13/12/11/9.5	17/15/12/10
	Heating					
Outside air intake			Possible			
Refrigerant Type			R32		R410A	
Refrigerant piping size (Flare)	Liquid	mm (in)	ø6.35(1/4")	ø9.52(3/8")	ø6.35(1/4")	ø9.52(3/8")
	Gas		ø12.7(1/2")	ø15.88(5/8")	ø12.7(1/2")	ø15.88(5/8")
Panel (Option)			TS-PSA-3AW-E			
Air filter, Q'ty			Pocket plastic net x 2(Washable)			

1. The data are measured under the following conditions (ISO-T1). Cooling: Indoor temp. of 27°CDB, 19°CWB, and outdoor temp. of 35°CDB. Heating: Indoor temp. of 20°CDB, and outdoor temp. of 7°CDB, 6°CWB.  
2. Sound pressure level indicates the value in an anechoic chamber. During operation these values are somewhat higher due to ambient conditions.

# Ceiling Cassette -1way Compact-FDTQ

New

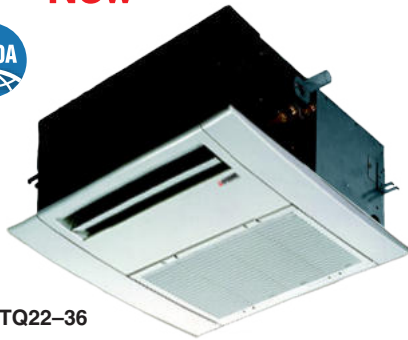

FDTQ22-36

R32 Leak detector and shut-off valve available as an option

Refrigerant leak detector  
RLD-KIT-E



Shut-off valve  
SV-KIT-S1N-E  
SV-KIT-L1N-E



For this model a relay kit (SV-RLY-E) is required to connect to the shut-off valve.

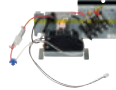

Remote control (Option)

Wired



RC-EX3D



RC-E5



RC-ES1

Wireless



RCN-KIT4-E2

\*R32 indoor unit are not compatible with R410A outdoor unit and vice versa.

## Compact design

- Comfortable effective cooling for small rooms, with low fan speed air flow at just 5.4m<sup>3</sup>/min.



Optional wide panel shown for solid ceiling

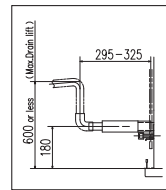

- Condensate drain pump included as standard

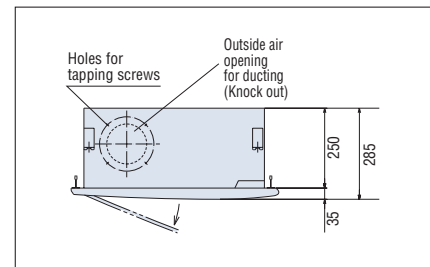

- Ultra slim design at just 250mm above the ceiling

## Motion Sensor

(Option)

Motion sensor is equipped in the ceiling plane or wall plane and detects the presence/absence and activity of humans in a room to improve the comfort and energy saving performance of the unit.



LB-KIT2

## SPECIFICATIONS

Indoor unit			FDTQ	22KXZE3-W	28KXZE3-W	36KXZE3-W	22KXE6F	28KXE6F	36KXE6F
Panel Name			Direct blow panel						
Panel (Option)			TQ-PSA-15W-E (Short Panel)						
			TQ-PSB-15W-E (Wide Panel)						
Power source			1 Phase 220-240V, 50Hz						
Nominal capacity	Cooling	kW	2.2	2.8	3.6	2.2	2.8	3.6	
	Heating		2.5	3.2	4.0	2.5	3.2	4.0	
Power consumption	Cooling	W	50-70						
	Heating		50-70						
Sound power level <sup>1</sup>	Cooling	dB(A)	56				60		
	Heating		56				60		
Sound pressure level <sup>1</sup> (P-Hi/Hi/Me/Lo)	Cooling	dB(A)	45/41/38/34				45/41/38/33		
	Heating		45/41/38/34				45/41/38/33		
Exterior dimensions (H × W × D)	Unit	mm	250 × 570 × 570						
	Panel		35 × 625 × 650 (TQ-PSA-15W-E), 35 × 780 × 650 (TQ-PSB-15W-E)						
Net weight	Unit	kg	19						
	Panel		2.5(TQ-PSA-15W-E), 3(TQ-PSB-15W-E)						
Air flow (P-Hi/Hi/Me/Lo)	Cooling	m <sup>3</sup> /min	8/7/6/5						
	Heating		8/7/6/5						
Outside air intake			Possible						
Refrigerant Type			R32				R410A		
Refrigerant piping size (Flare)	Liquid	mm (in)	ø6.35(1/4")						
	Gas		ø9.52(3/8")		ø12.7(1/2")		ø9.52(3/8")		ø12.7(1/2")
Air filter, Q'ty			Pocket plastic net × 1(Washable)						

1. The data are measured under the following conditions(ISO-T1). Cooling: Indoor temp. of 27°CDB, 19°CWB, and outdoor temp. of 35°CDB. Heating: Indoor temp. of 20°CDB, and outdoor temp. of 7°CDB, 6°CWB.  
2. Sound pressure level indicates the value in an anechoic chamber. During operation these values are somewhat higher due to ambient conditions.

# Duct Connected -High Static Pressure- FDU



**New**



FDU45-160



FDU224 · 280

\*R32 indoor unit are not compatible with R410A outdoor unit and vice versa.

## Remote control (Option)

Wired



RC-EX3D



RC-E5



RC-ES1

Wireless



RCN-KIT4-E2

## R32 Leak detector and shut-off valve available as an option

Refrigerant leak detector  
RLD-KIT-E

Shut-off valve  
SV-KIT-S1N-E  
SV-KIT-L1N-E



### Static pressure could be adjusted via the remote control



The static pressure of the air duct could simply be adjusted via the remote control thereby work above the ceiling to adjust is no longer required.

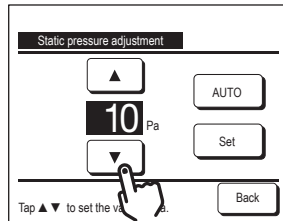
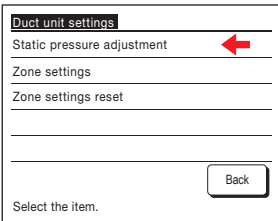

### Thin design

The height of FDU (45-160) models are only 280mm

280mm



### Transparent inspection window

Dirt condition of the bottom of the drain pan can be checked through this transparent inspection window without removing drain pan. (Please refer to P92)

### Improvement of the serviceability

Fan unit (impeller and motor) can be pulled out from the right side of the unit. Maintenance can be carried out from the right side or the bottom side of the unit.

### Reduction of sound pressure level

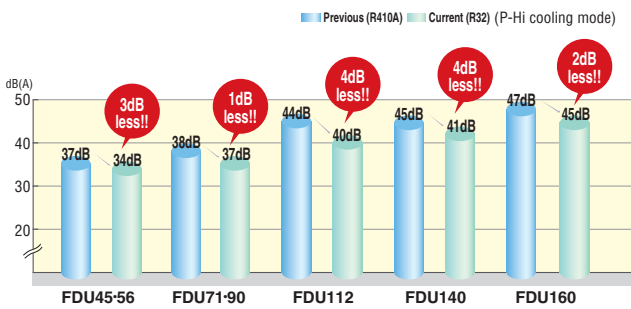

### Motion Sensor

(Option)

Motion sensor is equipped in the ceiling plane and detects the presence/absence and activity of humans in a room to improve the comfort and energy saving performance of the unit.



LB-KIT2

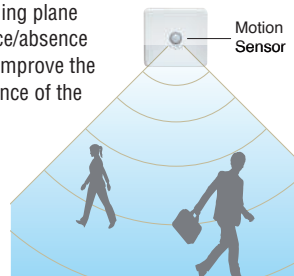

### Unit image

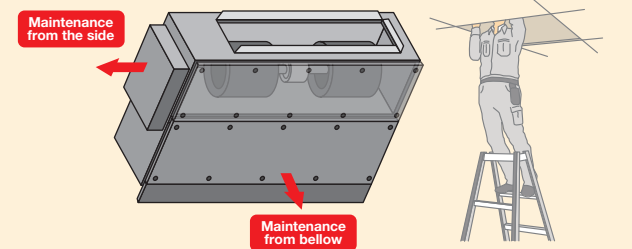

### Opening from the side

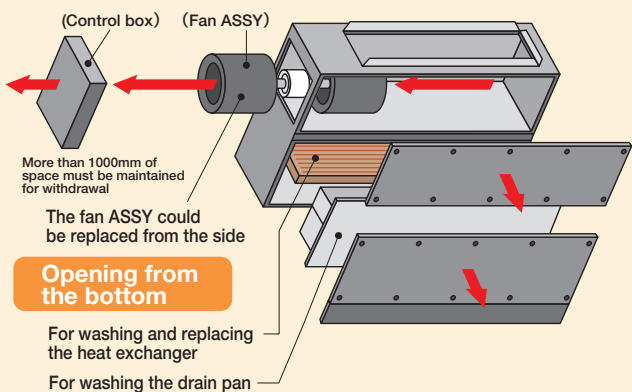

### Opening from the bottom

For washing and replacing the heat exchanger  
For washing the drain pan

## SPECIFICATIONS

Indoor unit	FDU		45KXE3-W	56KXE3-W	71KXE3-W	90KXE3-W	112KXE3-W	140KXE3-W	160KXE3-W	224KXE3-W	280KXE3-W
Power source			1 Phase 220-240V, 50Hz								
Nominal capacity	Cooling	kW	4.5	5.6	7.1	9.0	11.2	14.0	16.0	22.4	28.0
	Heating		5.0	6.3	8.0	10.0	12.5	16.0	18.0	25.0	31.5
Power consumption	Cooling	W	100-100		240-250		310-320	350-360	420-430	1.160-1.200	
	Heating										
Sound power level <sup>1</sup>	Cooling	dB(A)	58		63		68		72	78	
	Heating		60		65		69				
Sound pressure level <sup>1</sup> (P-Hi/Hi/Me/Lo)	Cooling	dB(A)	34/29/27/25		37/31/27/22		40/36/34/28	41/37/34/28	45/38/34/29	52/50/47/44	
	Heating		35/30/29/25		39/33/28/23		41/36/34/28				
Exterior dimensions (H x W x D)		mm	280 x 750 x 635		280 x 950 x 635		280 x 1368 x 738			379 x 1600 x 893	
Net weight		kg	29		34		54			89	
Air flow (P-Hi/Hi/Me/Lo)	Cooling	m <sup>3</sup> /min	13/10/9/8		24/19/15/10		36/28/25/19	39/32/26/20	48/35/28/22	80/72/64/56	
	Heating										
Available static pressure		Pa	200								
Outside air intake			Possible								
Refrigerant Type			R32								
Refrigerant piping size	Liquid	mm (in)	ø6.35(1/4") (Flare)		ø9.52(3/8") (Flare)			ø9.52(3/8") (Brazing)			
	Gas		ø12.7(1/2") (Flare)		ø15.88(5/8") (Flare)			ø19.05(3/4") (Brazing)	ø22.22(7/8") (Brazing)		
Air filter, Q'ty			Procure locally								

Indoor unit	FDU		45KXE6F	56KXE6F	71KXE6F	90KXE6F	112KXE6F	140KXE6F	160KXE6F	224KXE1	280KXE1
Power source			1 Phase 220-240V, 50Hz								
Nominal capacity	Cooling	kW	4.5	5.6	7.1	9.0	11.2	14.0	16.0	22.4	28.0
	Heating		5.0	6.3	8.0	10.0	12.5	16.0	18.0	25.0	31.5
Power consumption	Cooling	W	100-100		240-250		310-320	350-360	420-430	1.160-1.200	
	Heating										
Sound power level <sup>1</sup>	Cooling	dB(A)	60		65		71	72	74	75	
	Heating										
Sound pressure level <sup>1</sup> (P-Hi/Hi/Me/Lo)	Cooling	dB(A)	37/32/29/26		38/33/29/25		44/38/36/30	45/40/34/29	47/40/35/30	52/50/47/45	
	Heating										
Exterior dimensions (H x W x D)		mm	280 x 750 x 635		280 x 950 x 635		280 x 1368 x 740			379 x 1600 x 893	
Net weight		kg	29		34		54			89	
Air flow (P-Hi/Hi/Me/Lo)	Cooling	m <sup>3</sup> /min	13/10/9/8		24/19/15/10		36/28/25/19	39/32/26/20	48/35/28/22	80/72/64/56	
	Heating										
Available static pressure		Pa	200								
Outside air intake			Possible								
Refrigerant Type			R410A								
Refrigerant piping size	Liquid	mm (in)	ø6.35(1/4") (Flare)		ø9.52(3/8") (Flare)			ø9.52(3/8") (Brazing)			
	Gas		ø12.7(1/2") (Flare)		ø15.88(5/8") (Flare)			ø19.05(3/4") (Brazing)	ø22.22(7/8") (Brazing)		
Air filter, Q'ty			Procure locally								

1. The data are measured under the following conditions (ISO-T1). Cooling: Indoor temp. of 27°CDB, 19°CWB, and outdoor temp. of 35°CDB. Heating: Indoor temp. of 20°CDB, and outdoor temp. of 7°CDB, 6°CWB.  
2. Sound pressure level indicates the value in an anechoic chamber. During operation these values are somewhat higher due to ambient conditions.

## Round duct adapter (Available for FDU 45–160, FDUM 22–160)

Company: AIRZONE  
URL: <http://www.airzone.es>

All-in-one solution: the whole zoning system in a plug&play device perfectly adapted to the indoor DX unit



### Main components

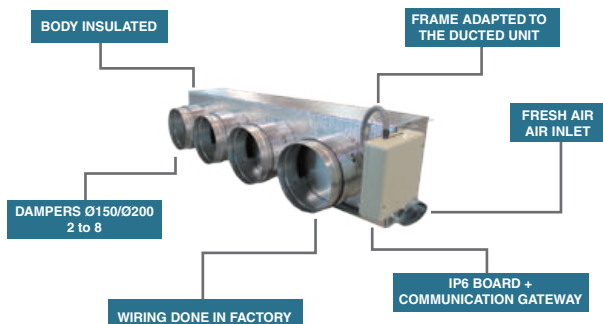
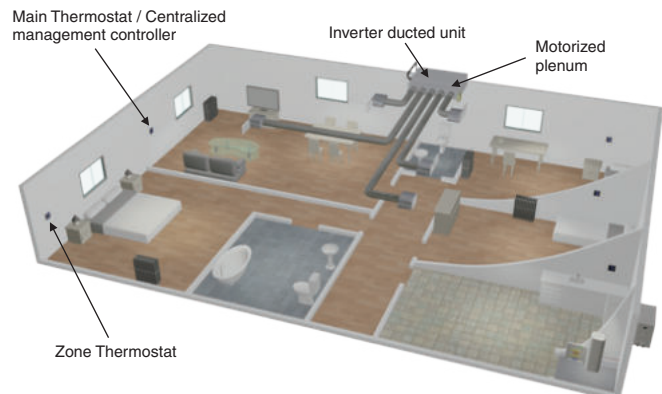

# Duct Connected -Low/Middle Static Pressure- FDUM



**New**



FDUM22-160



\*Filter pressure loss:5Pa

### Filter kit (Option)

- UM-FL1EF : for 22-56
- UM-FL2EF : for 71, 90
- UM-FL3EF : for 112, 140, 160

### Remote control (Option)

Wired



RC-EX3D



RC-E5



RC-ES1

Wireless



RCN-KIT4-E2

### R32 Leak detector and shut-off valve available as an option

Refrigerant leak detector  
RLD-KIT-E



Shut-off valve  
SV-KIT-S1N-E  
SV-KIT-L1N-E



\*R32 indoor unit are not compatible with R410A outdoor unit and vice versa.

### Static pressure could be adjusted via the remote control

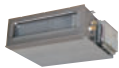

The static pressure of the air duct could simply be adjusted via the remote control thereby work above the ceiling to adjust is no longer required.

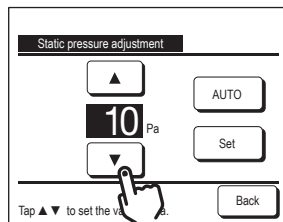
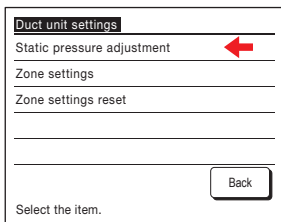

### Thin design

The height of all FDUM models only 280mm



### Transparent inspection window

Dirt condition of the bottom of the drain pan can be checked through this transparent inspection window without removing drain pan. (Please refer to P92)

### Motion Sensor

(Option)

Motion sensor is equipped in the ceiling plane or wall plane and detects the presence/absence and activity of humans in a room to improve the comfort and energy saving performance of the unit.

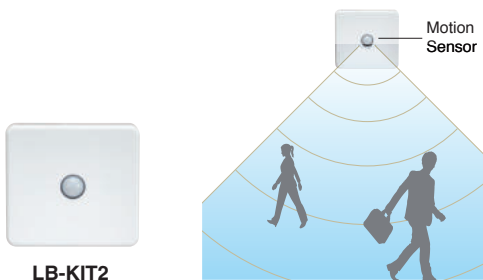

LB-KIT2

### Improvement of the serviceability

Fan unit (impeller and motor) can be pulled out from the right side of the unit. Maintenance can be carried out from the right side or the bottom side of the unit.

### Round duct adapter

In case of requirements of round duct adapter, please refer to P97.

Company AIRZONE  
URL <http://www.airzone.es>

### Unit image

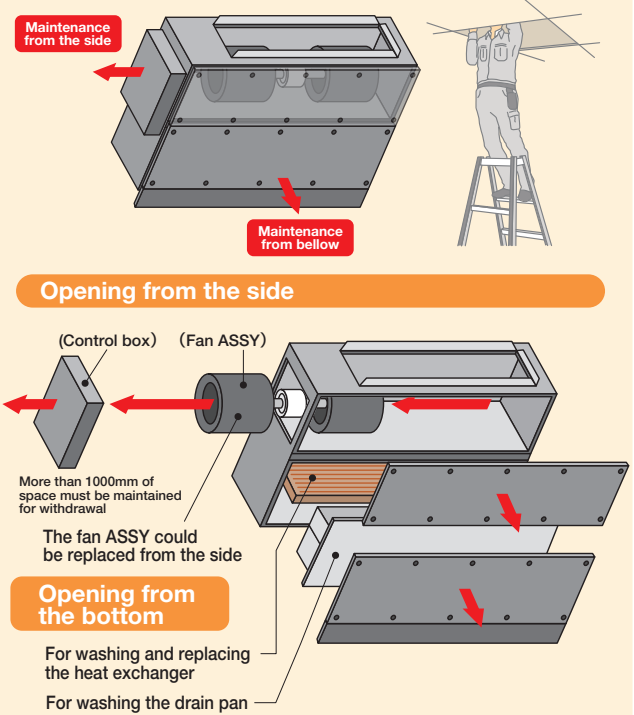

## SPECIFICATIONS

Indoor unit	FDUM		22KXZE3-W	28KXZE3-W	36KXZE3-W	45KXZE3-W	56KXZE3-W	71KXZE3-W	90KXZE3-W	112KXZE3-W	140KXZE3-W	160KXZE3-W	
Power source			1 Phase 220-240V, 50Hz										
Nominal capacity	Cooling	kW	2.2	2.8	3.6	4.5	5.6	7.1	9.0	11.2	14.0	16.0	
	Heating		2.5	3.2	4.0	5.0	6.3	8.0	10.0	12.5	16.0	18.0	
Power consumption	Cooling	W	80-80				160-160			250-250	260-260	380-380	
	Heating		80-80				160-160			250-250	260-260	380-380	
Sound power level <sup>1</sup>	Cooling	dB(A)	57			58			63		68		72
	Heating		60			60			65		69		
Sound pressure level <sup>1</sup> (P-Hi/Hi/Me/Lo)	Cooling	dB(A)	33/27/25/23		34/29/27/25			37/31/27/22		40/36/34/28		41/37/34/28	45/38/34/29
	Heating		36/30/29/25		35/30/29/25			39/33/28/23		41/36/34/28			
Exterior dimensions (H × W × D)		mm	280 × 750 × 635				280 × 950 × 635			280 × 1368 × 738			
Net weight		kg	29				34			54			
Air flow (P-Hi/Hi/Me/Lo)	Cooling	m <sup>3</sup> / min	13/10/9/8				24/19/15/10			36/28/25/19	39/32/26/20	48/35/28/22	
	Heating		13/10/9/8				24/19/15/10			36/28/25/19	39/32/26/20	48/35/28/22	
Available static pressure		Pa	100										
Outside air intake			Possible										
Refrigerant Type			R32										
Refrigerant piping size (Flare)	Liquid	mm (in)	ø6.35(1/4")				ø9.52(3/8")			ø15.88(5/8")			
	Gas		ø9.52(3/8")		ø12.7(1/2")			ø15.88(5/8")					
Air filter (Option)			UM-FL1EF				UM-FL2EF			UM-FL3EF			

Indoor unit	FDUM		22KXE6F	28KXE6F	36KXE6F	45KXE6F	56KXE6F	71KXE6F	90KXE6F	112KXE6F	140KXE6F	160KXE6F	
Power source			1 Phase 220-240V, 50Hz										
Nominal capacity	Cooling	kW	2.2	2.8	3.6	4.5	5.6	7.1	9.0	11.2	14.0	16.0	
	Heating		2.5	3.2	4.0	5.0	6.3	8.0	10.0	12.5	16.0	18.0	
Power consumption	Cooling	W	100-100				200-200			290-290	330-330	450-450	
	Heating		100-100				200-200			290-290	330-330	450-450	
Sound power level <sup>1</sup>	Cooling	dB(A)	60				65			71	72	74	
	Heating		60				65			71	72	74	
Sound pressure level <sup>1</sup> (P-Hi/Hi/Me/Lo)	Cooling	dB(A)	37/32/29/26				38/33/29/25			44/38/36/30	45/40/34/29	47/40/35/30	
	Heating		37/32/29/26				38/33/29/25			44/38/36/30	45/40/34/29	47/40/35/30	
Exterior dimensions (H × W × D)		mm	280 × 750 × 635				280 × 950 × 635			280 × 1368 × 740			
Net weight		kg	29				34			54			
Air flow (P-Hi/Hi/Me/Lo)	Cooling	m <sup>3</sup> / min	13/10/9/8				24/19/15/10			36/28/25/19	39/32/26/20	48/35/28/22	
	Heating		13/10/9/8				24/19/15/10			36/28/25/19	39/32/26/20	48/35/28/22	
Available static pressure		Pa	100										
Outside air intake			Possible										
Refrigerant Type			R410A										
Refrigerant piping size (Flare)	Liquid	mm (in)	ø6.35(1/4")				ø9.52(3/8")			ø15.88(5/8")			
	Gas		ø9.52(3/8")		ø12.7(1/2")			ø15.88(5/8")					
Air filter (Option)			UM-FL1EF				UM-FL2EF			UM-FL3EF			

1. The data are measured under the following conditions (ISO-T1). Cooling: Indoor temp. of 27°CDB, 19°CWB, and outdoor temp. of 35°CDB. Heating: Indoor temp. of 20°CDB, and outdoor temp. of 7°CDB, 6°CWB.  
2. Sound pressure level indicates the value in an anechoic chamber. During operation these values are somewhat higher due to ambient conditions.

# Duct Connected (thin) -Low Static Pressure- FDUT



**New**

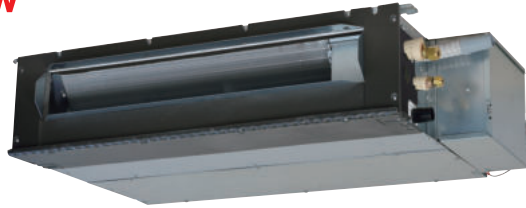

FDUT15-71

## Remote control (Option)

Wired



RC-EX3D



RC-E5



RC-ES1

Wireless



RCN-KIT4-E2

## R32 Leak detector and shut-off valve available as an option

Refrigerant leak detector  
RLD-KIT-E



Shut-off valve  
SV-KIT-S1N-E  
SV-KIT-L1N-E



For this model a relay kit (SV-RLY-E) is required to connect to the shut-off valve.  
\*Excluding FDUT71KXZE3-W

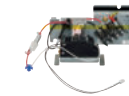

\*R32 indoor unit are not compatible with R410A outdoor unit and vice versa.

## Motion Sensor (Option)

Motion sensor is equipped in the ceiling plane or wall plane and detects the presence/absence and activity of humans in a room to improve the comfort and energy saving performance of the unit.

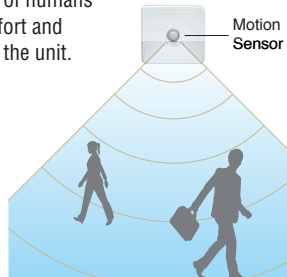

LB-KIT2

## Filter kit (Option)

Item	Contents	for FDUT15/22/28/36	for FDUT45/56	for FDUT71
Outlet duct plate	①	UT-SAT1EF	UT-SAT2EF	UT-SAT3EF
Filter set	②+③	UT-FL1EF	UT-FL2EF	UT-FL3EF

Filter pressure loss : 5 Pa

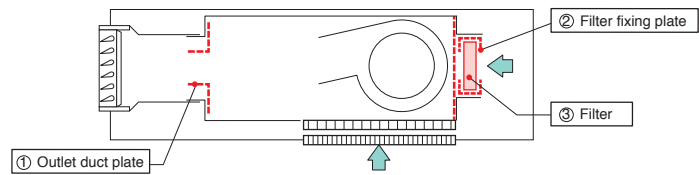

## SPECIFICATIONS

Indoor unit		FDUT	15KXZE3-W	22KXZE3-W	28KXZE3-W	36KXZE3-W	45KXZE3-W	56KXZE3-W	71KXZE3-W	
Power source			1 Phase 220-240V, 50Hz							
Nominal capacity	Cooling	kW	1.5	2.2	2.8	3.6	4.5	5.6	7.1	
	Heating		1.7	2.5	3.2	4.0	5.0	6.0	8.0	
Power consumption	Cooling	W	57-58	63-66		67-70	75-78	76-80	80-80	
	Heating			65-67		70-72	72-76	73-78	70-70	
Sound power level <sup>1</sup>	Cooling	dB(A)	52	52		54	54	55	56	
	Heating		51			55			57	
Sound pressure level <sup>1</sup> (Hi/Me/Lo)	Cooling	dB(A)	28/26/21	28/26/22		30/28/24	30/26/24	31/27/24	32/28/27	
	Heating		28/25/20			31/29/25	30/27/25	31/28/26	32/28/26	
Sound pressure level <sup>2</sup> (Hi/Me/Lo)	Cooling	dB(A)	32/29/25	32/29/25		37/34/28	36/33/27	38/33/29	41/37/32	
	Heating									
Exterior dimensions (H × W × D)		mm	200 × 750 × 500				200 × 950 × 500		220 × 1150 × 565	
Net weight		kg	22	21		22	25		31	
Air flow (Hi/Me/Lo)	Cooling	m <sup>3</sup> /min	6/5/4	7.5/6/5		8.5/7/5.5	11.5/9/7	12.5/9/7.2	16/13/9.5	
	Heating									
External static pressure		Pa	Standard : 10 Max : 35				Standard : 10 Max : 50			
Outside air intake			Possible							
Refrigerant Type			R32							
Refrigerant piping size (Flare)	Liquid	mm (in)	ø6.35(1/4")						ø9.52(3/8")	
	Gas		ø9.52(3/8")			ø12.7(1/2")			ø15.88(5/8")	
Air filter (Option)			UT-FL1EF			UT-FL2EF		UT-FL3EF		

- The data are measured under the following conditions (ISO-T1). Cooling: Indoor temp. of 27°CDB, 19°CWB, and outdoor temp. of 35°CDB. Heating: Indoor temp. of 20°CDB, and outdoor temp. of 7°CDB, 6°CWB.
- The data of nominal cooling and heating capacity and sound pressure level are measured with 10Pa of external static pressure.
- The sound level indicates the value of rear-intake type with duct in anechoic chamber. During operation these values are somewhat higher due to ambient conditions.
- Sound Pressure Level shows the value when the supply duct of 2m and the return duct of 1m (except the Bottom air return) are connected to the unit. Sound pressure level \*1: Mike position is 1.5m below the unit, \*2: Mike position is 1m in front and 1m below the air supply duct.

Indoor unit	FDUT		15KXE6F-E	22KXE6F-E	28KXE6F-E	36KXE6F-E	45KXE6F-E	56KXE6F-E	71KXE6F-E	
Power source			1 Phase 220-240V, 50Hz							
Nominal capacity	Cooling	kW	1.5	2.2	2.8	3.6	4.5	5.6	7.1	
	Heating		1.7	2.5	3.2	4.0	5.0	6.0	8.0	
Power consumption	Cooling	W	60-60	70-70			80-80		80-80	
	Heating								70-70	
Sound power level <sup>1</sup>	Cooling	dB(A)	52			57	58	59		
	Heating		52			57	58	59		
Sound pressure level <sup>1</sup> (Hi/Me/Lo)	Cooling	dB(A)	28/26/22			33/30/26	34/32/28	35/33/30	35/31/28	
	Heating		28/26/22			33/30/26	34/32/28	35/33/30	35/31/28	
Sound pressure level <sup>2</sup> (Hi/Me/Lo)	Cooling	dB(A)	32/29/25			37/34/28	36/33/27	38/33/29	41/37/32	
	Heating		32/29/25			37/34/28	36/33/27	38/33/29	41/37/32	
Exterior dimensions (H × W × D)		mm	200 × 750 × 500				200 × 950 × 500		220 × 1150 × 565	
Net weight		kg	22	21		22	25		31	
Air flow (Hi/Me/Lo)	Cooling	m <sup>3</sup> /min	6/5/4	7.5/6/5		8.5/7/5.5	11.5/9/7	12.5/9/7.2	16/13/9.5	
	Heating									
External static pressure		Pa	Standard : 10 Max : 35				Standard : 10 Max : 50			
Outside air intake			Possible							
Refrigerant Type			R410A							
Refrigerant piping size (Flare)	Liquid	mm (in)	ø6.35(1/4")						ø9.52(3/8")	
	Gas		ø9.52(3/8")			ø12.7(1/2")			ø15.88(5/8")	
Air filter (Option)			UT-FL1EF			UT-FL2EF		UT-FL3EF		

1. The data are measured under the following conditions(ISO-T1). Cooling: Indoor temp. of 27°CDB, 19°CWB, and outdoor temp. of 35°CDB. Heating: Indoor temp. of 20°CDB, and outdoor temp. of 7°CDB, 6°CWB.
  2. The data of nominal cooling and heating capacity and sound pressure level are measured with 10Pa of external static pressure.
  3. The sound level indicates the value of rear-intake type with duct in anechoic chamber. During operation these values are somewhat higher due to ambient conditions.
  4. Sound Pressure Level shows the value when the supply duct of 2m and the return duct of 1m (except the Bottom air return) are connected the unit.
- Sound pressure level \*1:Mike position is 1.5m below the unit, \*2:Mike position is 1m in front and 1m below od the air supply duct.

# Duct Connected (Compact & Flexible)

## FDUH

**New**



FDUH22-36

### Filter kit (Option) UH-FL1E



\*Filter pressure loss:5Pa

### Drain up kit (Option) (600mm) UH-DU-E

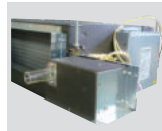

### R32 Leak detector and shut-off valve available as an option

Refrigerant leak detector  
RLD-KIT-E



Shut-off valve  
SV-KIT-S1N-E  
SV-KIT-L1N-E



### Remote control (Option)

Wired



RC-EX3D



RC-E5



RC-ES1

Wireless



RCN-KIT4-E2

For this model a relay kit (SV-RLY-E) is required to connect to the shut-off valve.

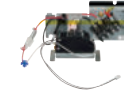

\*R32 indoor unit are not compatible with R410A outdoor unit and vice versa.

### Compact and thin size, light weight

Our leading high technology has created the best solution for air-conditioning in hotels. The compact and thin sized units don't compromise on high energy efficiency all while weighing in at only 20kg. The lowest sound level in the industry can ensure comfortable stay and rest in hotels.

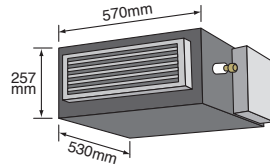

### Motion Sensor (Option)

Motion sensor is equipped in the ceiling plane or wall plane and detects the presence/absence and activity of humans in a room to improve the comfort and energy saving performance of the unit.



LB-KIT2

### Installation Flexibility

Control box and drain piping can be installed on both side of the unit and air intake to the unit is available from bottom or back side. Our highest technology can satisfy diverse installation requirements.

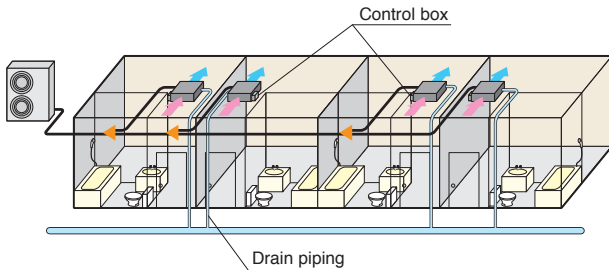

## SPECIFICATIONS

Indoor unit		FDUH	22KXZE3-W	28KXZE3-W	36KXZE3-W	22KXE6F	28KXE6F	36KXE6F
Power source			1 Phase 220-240V, 50Hz					
Nominal capacity	Cooling	kW	2.2	2.8	3.6	2.2	2.8	3.6
	Heating	kW	2.5	3.2	4.0	2.5	3.2	4.0
Power consumption	Cooling	W	50-70					
	Heating	W	50-70					
Sound power level <sup>1</sup>	Cooling	dB(A)	58			60		
	Heating	dB(A)	58			60		
Sound pressure level <sup>1</sup> (P-Hi/Hi/Me/Lo)	Cooling	dB(A)	36/33/30/27			39/33/30/27		
	Heating	dB(A)	36/33/30/27			39/33/30/27		
Exterior dimensions (H × W × D)		mm	256 × 550 × 525			257 × 570 × 530		
Net weight		kg	19			20		
Air flow (P-Hi/Hi/Me/Lo)	Cooling	m <sup>3</sup> /min	8.5/7/6.5/6					
	Heating	m <sup>3</sup> /min	8.5/7/6.5/6					
Static pressure		Pa	30					
Outside air intake			Not possible					
Refrigerant Type			R32			R410A		
Refrigerant piping size (Flare)	Liquid	mm	ø6.35(1/4")					
	Gas	(in)	ø9.52(3/8")		ø12.7(1/2")		ø9.52(3/8")	
Air filter (Option)			UH-FL1E					

1. The data are measured under the following conditions(SO-T1). Cooling: Indoor temp. of 27°CDB, 19°CWB, and outdoor temp. of 35°CDB. Heating: Indoor temp. of 20°CDB, and outdoor temp. of 7°CDB, 6°CWB.  
2. Sound pressure level indicates the value in an anechoic chamber. During operation these values are somewhat higher due to ambient conditions.

# Wall Mounted FDK



**New**



FDK15-56



FDK71-90

## Remote control (Option)

Wired



RC-EX3D



RC-E5



RC-ES1

Wireless



RCN-K-E2:  
FDK15-56



RCN-K71-E2:  
FDK71-90

## R32 Leak detector and shut-off valve available as an option

Refrigerant leak detector  
RLD-KIT-E



Shut-off valve  
SV-KIT-S1N-E  
SV-KIT-L1N-E



\*R32 indoor unit are not compatible with R410A outdoor unit and vice versa.

### Elegant Timeless Design

The FDK series air-conditioners are innovatively designed with rounded contours that beautifully fit into any of Europe's diverse interior settings. Created by an Italian industrial design studio based in Milan, Tensa srl, the design meets a broad range of requirements. (FDK15-56)

### Flap control system

Selection of flap position is possible. A flap can be set at different angles.

\*The wireless remote control is not applicable to the flap control system.

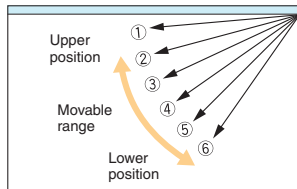

**Lateral Swing** ▶ flap swings from right to left automatically

**Up/Down Flap swing + Lateral swing**

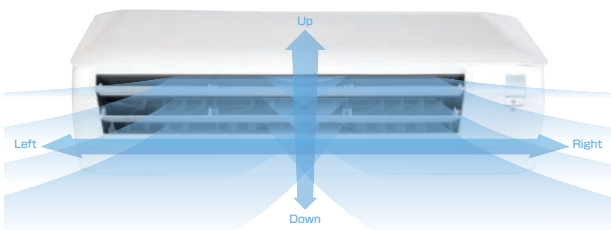

### Jet Technology

FDK models adopt the air flow design that's proven to minimise resistance in a CFD analysis to achieve uniform air-conditioning to the furthest corners of the room.

Fast ← → Slow  
Colours in the figure show the air speed.

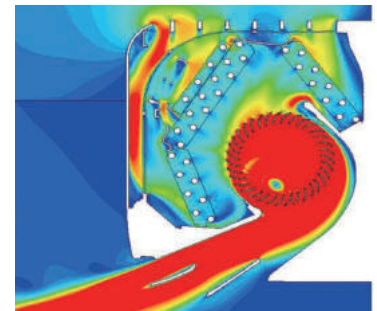

### Motion Sensor

(Option)

Motion sensor is equipped in the ceiling plane or wall plane and detects the presence/absence and activity of humans in a room to improve the comfort and energy saving performance of the unit.



LB-KIT2

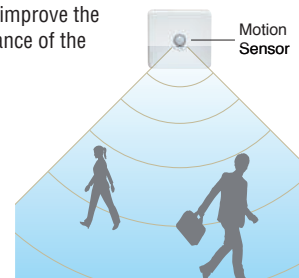

## ■ SPECIFICATIONS

Indoor unit		FDK	15KXZE3-W	22KXZE3-W	28KXZE3-W	36KXZE3-W	45KXZE3-W	56KXZE3-W	71KXZE3-W	90KXZE3-W
Power source		1 Phase 220-240V, 50Hz								
Nominal capacity	Cooling	kW	1.5	2.2	2.8	3.6	4.5	5.6	7.1	9.0
	Heating		1.7	2.5	3.2	4.0	5.0	6.3	8.0	10.0
Power consumption	Cooling	W	20-20			30-30			40-40	50-50
	Heating									
Sound power level <sup>†</sup>	Cooling	dB(A)	54	55		58		58	59	61
	Heating									
Sound pressure level <sup>†</sup> (P-Hi/Hi/Me/Lo)	Cooling	dB(A)	38/34/31/28	38/36/30/27		40/38/33/28	43/41/36/33	43/41/36/33	42/40/37/35	44/42/39/35
	Heating									
Exterior dimensions (H × W × D)		mm	290 × 870 × 230						339 × 1197 × 262	
Net weight		kg	11.5	11		11.5		17		
Air flow (P-Hi/Hi/Me/Lo)	Cooling	m <sup>3</sup> / min	5.7/5/4.5/3.6	8.5/8/6/5		11/10/8/7	12/11/9/8	12/11/9/8	21/19/16/14	23/21/19/16
	Heating									
Outside air intake		Not possible								
Refrigerant Type		R32								
Refrigerant piping size (Flare)	Liquid	mm (in)	ø6.35(1/4")						ø9.52(3/8")	
	Gas		ø9.52(3/8")		ø12.7(1/2")		ø15.88(5/8")			
Air filter, Q'ty		Polypropylene net × 2 (Washable)								

Indoor unit		FDK	15KXZE1	22KXZE1	28KXZE1	36KXZE1	45KXZE1	56KXZE1	71KXZE1	90KXZE1
Power source		1 Phase 220-240V, 50Hz								
Nominal capacity	Cooling	kW	1.5	2.2	2.8	3.6	4.5	5.6	7.1	9.0
	Heating		1.7	2.5	3.2	4.0	5.0	6.3	8.0	10.0
Power consumption	Cooling	W	20-20			30-30			40-40	50-50
	Heating									
Sound power level <sup>†</sup>	Cooling	dB(A)	54	55		58		58	59	61
	Heating									
Sound pressure level <sup>†</sup> (P-Hi/Hi/Me/Lo)	Cooling	dB(A)	38/34/31/28	38/36/32/28		40/38/33/28	43/41/36/33	43/41/36/33	42/40/37/35	44/42/39/35
	Heating									
Exterior dimensions (H × W × D)		mm	290 × 870 × 230						339 × 1197 × 262	
Net weight		kg	11.5	11		11.5		17		
Air flow (P-Hi/Hi/Me/Lo)	Cooling	m <sup>3</sup> / min	5.7/5/4.5/3.6	8.5/8/6/5		11/10/8/7	12/11/9/8	12/11/9/8	21/19/16/14	23/21/19/16
	Heating									
Outside air intake		Not possible								
Refrigerant Type		R410A								
Refrigerant piping size (Flare)	Liquid	mm (in)	ø6.35(1/4")						ø9.52(3/8")	
	Gas		ø9.52(3/8")		ø12.7(1/2")		ø15.88(5/8")			
Air filter, Q'ty		Polypropylene net × 2 (Washable)								

1. The data are measured under the following conditions (ISO-T1). Cooling: Indoor temp. of 27°CDB, 19°CWB, and outdoor temp. of 35°CDB. Heating: Indoor temp. of 20°CDB, and outdoor temp. of 7°CDB, 6°CWB.  
2. Sound pressure level indicates the value in an anechoic chamber. During operation these values are somewhat higher due to ambient conditions.

### External Expansion Valve Kit AP-EEV

External Expansion Valve Kit

ZZZ..

Gas Liquid

Outdoor Unit

The option is available for the following capacity.  
※The option is compatible with the other indoor unit besides the FDK series.

### Ideal for air conditioning applications requiring high quietness.

Reduces noise levels near idle  
indoor units by approximately 5 dB.

	R32	R410A
AP-EEV32-S	1.5kW	-
AP-EEV32-M	2.2-7.1kW	1.5kW
AP-EEV	9.0kW	2.2-7.1kW

# Ceiling Suspended FDE

New



FDE36-140

\*R32 indoor unit are not compatible with R410A outdoor unit and vice versa.

## Remote control (Option)

Wired



RC-EX3D



RC-E5



RC-ES1

Wireless



RCN-E-E3

## R32 Leak detector and shut-off valve available as an option

Refrigerant leak detector  
RLD-KIT-E

Shut-off valve  
SV-KIT-S1N-E  
SV-KIT-L1N-E



## Flap control system

Selection of flap position is possible.  
A flap can be set at different angles.

\*The wireless remote control is not applicable to the flap control system.

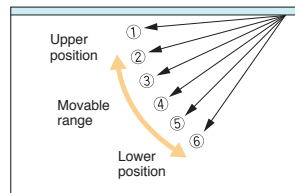

## Motion Sensor (Option)

By detecting presence or absence of human activity in a room, the motion sensor improves room comfort and unit energy saving performance.



LB-E

## SPECIFICATIONS

Indoor unit	FDE	36KXZE3-W	45KXZE3-W	56KXZE3-W	71KXZE3-W	112KXZE3-W	140KXZE3-W
Power source		1 Phase 220-240V, 50Hz					
Nominal capacity	Cooling	3.6	4.5	5.6	7.1	11.2	14.0
	Heating	4.0	5.0	6.3	8.0	12.5	16.0
Power consumption	Cooling	50-50			70-70	100-100	130-130
	Heating	50-50			70-70	100-100	130-130
Sound power level <sup>1</sup>	Cooling	59	59	59	61	61	64
	Heating	60	60	60	61	61	64
Sound pressure level <sup>1</sup> (P-Hi/Hi/Me/Lo)	Cooling	45/38/31/26	45/38/36/31		46/39/37/32	45/42/38/34	48/43/40/35
	Heating	45/38/31/26	45/38/36/31		46/39/37/32	45/42/38/34	48/43/40/35
Exterior dimensions (H × W × D)	mm	210 × 1070 × 690			210 × 1320 × 690	250 × 1620 × 690	
Net weight	kg	28			35	43	
Air flow (P-Hi/Hi/Me/Lo)	Cooling	13/10/7/5.5	13/10/9/7		20/15/13/10	28/25/21/16.5	32/26/23/17
	Heating	13/10/7/5.5	13/10/9/7		20/15/13/10	28/25/21/16.5	32/26/23/17
Outside air intake	Not possible						
Refrigerant Type	R32						
Refrigerant piping size (Flare)	Liquid	ø6.35(1/4")			ø9.52(3/8")		
	Gas	ø12.7(1/2")			ø15.88(5/8")		
Air filter, Q'ty	Pocket Plastic net × 2 (Washable)						

Indoor unit	FDE	36KXZE1	45KXZE1	56KXZE1	71KXZE1	112KXZE1	140KXZE1
Power source		1 Phase 220-240V, 50Hz					
Nominal capacity	Cooling	3.6	4.5	5.6	7.1	11.2	14.0
	Heating	4.0	5.0	6.3	8.0	12.5	16.0
Power consumption	Cooling	50-50			70-70	100-100	130-130
	Heating	50-50			70-70	100-100	130-130
Sound power level <sup>1</sup>	Cooling	60			62	61	64
	Heating	60			62	61	64
Sound pressure level <sup>1</sup> (P-Hi/Hi/Me/Lo)	Cooling	46/38/31/26	46/38/36/31		47/39/37/32	45/42/38/34	48/43/40/35
	Heating	46/38/31/26	46/38/36/31		47/39/37/32	45/42/38/34	48/43/40/35
Exterior dimensions (H × W × D)	mm	210 × 1070 × 690			210 × 1320 × 690	250 × 1620 × 690	
Net weight	kg	28			33	43	
Air flow (P-Hi/Hi/Me/Lo)	Cooling	13/10/7/5.5	13/10/9/7		20/15/13/10	28/25/21/16.5	32/26/23/17
	Heating	13/10/7/5.5	13/10/9/7		20/15/13/10	28/25/21/16.5	32/26/23/17
Outside air intake	Not possible						
Refrigerant Type	R410A						
Refrigerant piping size (Flare)	Liquid	ø6.35(1/4")			ø9.52(3/8")		
	Gas	ø12.7(1/2")			ø15.88(5/8")		
Air filter, Q'ty	Pocket Plastic net × 2 (Washable)						

1. The data are measured under the following conditions(ISO-T1). Cooling: Indoor temp. of 27°CDB, 19°CWB, and outdoor temp. of 35°CDB. Heating: Indoor temp. of 20°CDB, and outdoor temp. of 7°CDB, 6°CWB.  
2. Sound pressure level indicates the value in an anechoic chamber. During operation these values are somewhat higher due to ambient conditions.

# Floor Standing -2way- FDFW



**New**



**FDFW28-56**

\*R32 indoor unit are not compatible with R410A outdoor unit and vice versa.

## Remote control (Option)

Wired



RC-EX3D



RC-E5



RC-ES1

Wireless

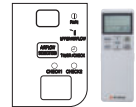

RCN-FW-E2

## Auto air outlet selection



### Flap control system

Selection of flap position is possible. A flap can be set at different angles.

\*The wireless remote control is not applicable to the flap control system.

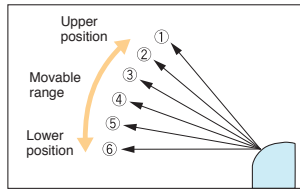

### Quiet Operation

Thanks to the optimum balance of air outlet direction and sufficient air flow volume, the sound level has been minimized. The level of FDFW28KXZE3-W in the cooling Lo mode is only 27dB(A).

### Convenient to use operation

Simultaneous lower and upper air outlets or upper outlet can be selected by air flow direction button. Further control can be arranged by a remote control.

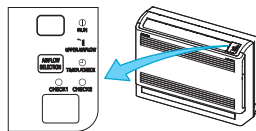

(In case of use of wireless remote control)

## R32 Leak detector and shut-off valve available as an option

Refrigerant leak detector RLD-KIT-E



Shut-off valve SV-KIT-S1N-E SV-KIT-L1N-E



For this model a relay kit (SV-RLY-E) is required to connect to the shut-off valve.

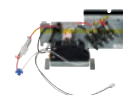

### Refrigerant leak detector Incorporated (Only for R32)



Refrigerant leak detector

The refrigerant leak sensor is built into the series. When a refrigerant leak is detected, it activates external safety devices such as shut-off valves or remote controllers.

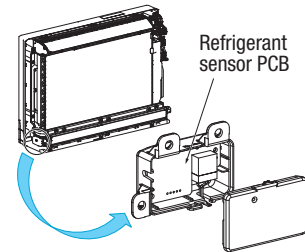

Refrigerant sensor PCB

## SPECIFICATIONS

Indoor unit	FDFW	28KXZE3-W	45KXZE3-W	56KXZE3-W	28KXE6F	45KXE6F	56KXE6F
Power source		1 Phase 220-240V, 50Hz					
Nominal capacity	Cooling	2.8	4.5	5.6	2.8	4.5	5.6
	Heating	3.2	5.0	6.3	3.2	5.0	6.3
Power consumption	Cooling	20-20		30-30	20-20		30-30
	Heating	20-20		30-30	20-20		30-30
Sound power level <sup>1</sup>	Cooling	48	51	57	55	57	60
	Heating	49	52	56			
Sound pressure level <sup>1</sup> (Hi/Me/Lo)	Cooling	35/33/27	38/36/31	44/37/31	36/34/30	38/36/33	44/37/33
	Heating	36/34/29	38/36/33	44/37/33			
Exterior dimensions (H × W × D)	mm	600 × 860 × 238					
Net weight	kg	18	19		19	20	
Air flow (Hi/Me/Lo)	Cooling	9/8/7		11/9/8	9/8/7		11/9/8
	Heating	9/8/7		11/9/8	9/8/7		11/9/8
Outside air intake		Not possible					
Refrigerant Type		R32			R410A		
Refrigerant piping size (Flare)	Liquid	ø6.35(1/4")			ø6.35(1/4")		
	Gas	ø9.52(3/8")	ø12.7(1/2")		ø9.52(3/8")	ø12.7(1/2")	
Air filter, Q'ty		Polypropylene net × 1 (Washable)					

1. The data are measured under the following conditions(SO-T1). Cooling: Indoor temp. of 27°CDB, 19°CWB, and outdoor temp. of 35°CDB. Heating: Indoor temp. of 20°CDB, and outdoor temp. of 7°CDB, 6°CWB.  
2. Sound pressure level indicates the value in an anechoic chamber. During operation these values are somewhat higher due to ambient conditions.

# Floor Standing (with casing) FDFL

# Floor Standing (without casing) FDFU



**New**



**FDFL71**

\*R32 indoor unit are not compatible with R410A outdoor unit and vice versa.

## Remote control (Option)

Wired



**RC-EX3D**



**RC-E5**



**RC-ES1**

Wireless



**RCN-KIT4-E2**



**FDFU28-71 (Concealed type)**

### Improved comfort with the air flow from a wide outlet

With the 60 degrees angle of the air flow from the front to the upper side the comfort has increased.

Piping could be taken from the side and the bottom leading to an improved serviceability and ease of installation.

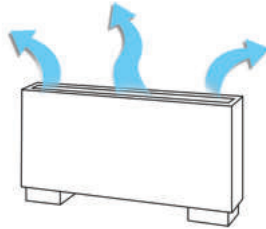

Wider air flow for optimum comfort

### Motion Sensor

(Option)

The optional motion sensor on our floor standing units saves energy by operations by detecting human movement. Our smart technology provides energy saving control by shifting set temperature by detecting human activity.



**LB-KIT2**

### R32 Leak detector and shut-off valve available as an option

Refrigerant leak detector  
RLD-KIT-E



Shut-off valve  
SV-KIT-S1N-E  
SV-KIT-L1N-E



For this model a relay kit (SV-RLY-E) is required to connect to the shut-off valve.

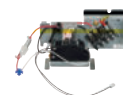

### Refrigerant leak detector incorporated (Only for R32)



Refrigerant leak detector

The refrigerant leak sensor is built into the series. When a refrigerant leak is detected, it activates external safety devices such as shut-off valves or remote controllers.

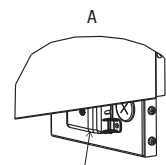
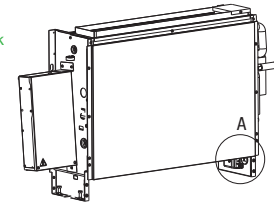

Refrigerant sensor

## SPECIFICATIONS

Indoor unit	FDL		71KXZE3-W	-	-	-	-	71KXE6F	-	-	-	-	
	FDFU		-	28KXZE3-W	45KXZE3-W	56KXZE3-W	71KXZE3-W	-	28KXE6F	45KXE6F	56KXE6F	71KXE6F	
Power source	1 Phase 220-240V, 50Hz												
Nominal capacity	Cooling	kW	7.1	2.8	4.5	5.6	7.1	7.1	2.8	4.5	5.6	7.1	
	Heating		8.0	3.2	5.0	6.3	8.0	8.0	3.2	5.0	6.3	8.0	
Power consumption	Cooling	W	90-100										
	Heating		90-100										
Sound power level <sup>1</sup> (Hi)	Cooling	dB(A)	61	60			61	62	58	60			
	Heating												
Sound pressure level <sup>1</sup> (Hi/Me/Lo)	Cooling	dB(A)	45/43/40	44/43/42	42/41/38		45/43/40	43/41/40	41/38/36	43/41/40			
	Heating		46/44/40										
Exterior dimensions (H x W x D)	mm		630 x 1481 x 225	630 x 1087 x 225			630 x 1372 x 225	630 x 1481 x 225	630 x 1087 x 225			630 x 1372 x 225	
Net weight	kg		46	27	29		35	46	27	29		35	
Air flow (Hi/Me/Lo)	Cooling	m <sup>3</sup> /min	18/15/12	12/11/10	14/12/10		18/15/12	18/15/12	12/11/10	14/12/10		18/15/12	
	Heating												
Outside air intake	Not possible												
Refrigerant Type	R32												
Refrigerant piping size (Flare)	Liquid	mm (in)	ø9.52(3/8")			ø6.35(1/4")			ø9.52(3/8")		ø6.35(1/4")		ø9.52(3/8")
	Gas		ø15.88(5/8")	ø9.52(3/8")	ø12.7(1/2")		ø15.88(5/8")	ø15.88(5/8")	ø9.52(3/8")	ø12.7(1/2")		ø15.88(5/8")	
Air filter, Q'ty	Polypropylene net x 1 (Washable)												

1. The data are measured under the following conditions(ISO-T1). Cooling: Indoor temp. of 27°CDB, 19°CWB, and outdoor temp. of 35°CDB. Heating: Indoor temp. of 20°CDB, and outdoor temp. of 7°CDB, 6°CWB.  
2. Sound pressure level indicates the value in an anechoic chamber. During operation these values are somewhat higher due to ambient conditions.

# Outdoor Air Processing unit FDU-F



**New**



**FDU650-2400F**

\*R32 indoor unit are not compatible with R410A outdoor unit and vice versa.

## Remote control (Option)

Wired



**RC-EX3D**



**RC-E5**



**RC-ES1**

Wireless



**RCN-KIT4-E2**

## R32 Leak detector and shut-off valve available as an option

Refrigerant leak detector  
**RLD-KIT-E**



Shut-off valve  
**SV-KIT-S1N-E**  
**SV-KIT-L1N-E**



For this model a relay kit (**SV-RLY-E**) is required to connect to the shut-off valve.

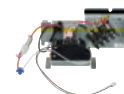

## Create a fresher environment with the Outdoor Air Processing feature

Connect your KXZ system to an Outdoor Air Processing unit with one streamlined system. This advanced technology allows you to enjoy a fresh and comfortable air supply.

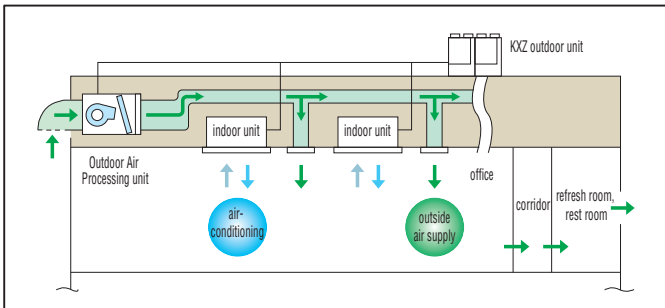

## Motion Sensor

(Option)

Built into the ceiling or wall plane, our motion sensor smart technology improves energy saving performance and overall room comfort.



**LB-KIT2**

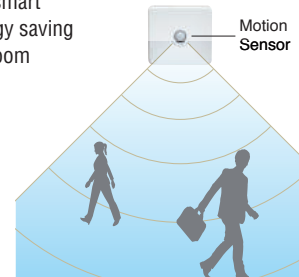

## Compact design

Compact design at just 280(650, 1100), 379(1800, 2400)mm in height, high static pressure of 200Pa and the industry's lowest noise level can meet various kind of installation locations for offices, refresh rooms, restrooms and kitchens of restaurants etc.

- (1) This unit is the specific unit for processing the outdoor air temperature closer to the room temperature. For conditioning the room temperature a dedicated air-conditioner is required additionally.
- (2) This unit monitors the outdoor air temperature and controls the thermostat's ON/OFF at the setting temperature by the remote controller, which indicates the outdoor air temperature for controlling the thermostat's ON/OFF. When the thermostat is turned OFF, the operation is changed to the fan mode so that unprocessed outdoor air will be blown into the room directly. Therefore place the air outlet port or orient the air outlet direction not to blow air directly to persons in the room, especially in small room such as a restroom and/or sanitary hot water supplying room.
- (3) It is strictly prohibited to monitor the room temperature by switching to the thermistor at the remote controller side and/or the optional remote thermistor. Otherwise dew formation at air outlet port and/or dew dripping may occur during cooling operation due to the lower outdoor air temperature. Therefore keep the remote controller of this unit in place closer to the administrator so as not to be touched freely by the end user.
- (4) Dehumidifying operation with this unit is prohibited.
- (5) When handing over this unit to the end user, make sure to explain sufficiently about the foregoing cautions, the installation place and usage of remote control for this unit and the location of the air outlet.

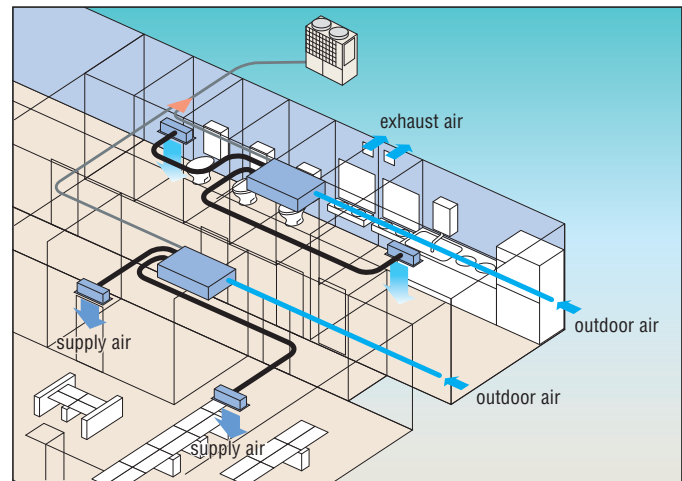

## Connectivity with Outdoor units

FDU-F series are connectable to 8-72HP KXZ3 8-60HP KXZ2 outdoor units, can not be connected to Micro model (4-6HP), KXZ Lite.

## Combination with Outdoor units

	case	Combination
A	Only OA processing units are connected with outdoor units.	The total capacity of FDU-F is 50-100% of outdoor capacity and max quantity of FDU-F is 2 units.
B	Both of OA processing units and dedicated air-conditioner are connected with outdoor units.	The total capacity of FDU-F and dedicated air-conditioners is 50-100% of outdoor capacity and max quantity of FDU-F should be below 30% of outdoor unit capacity.

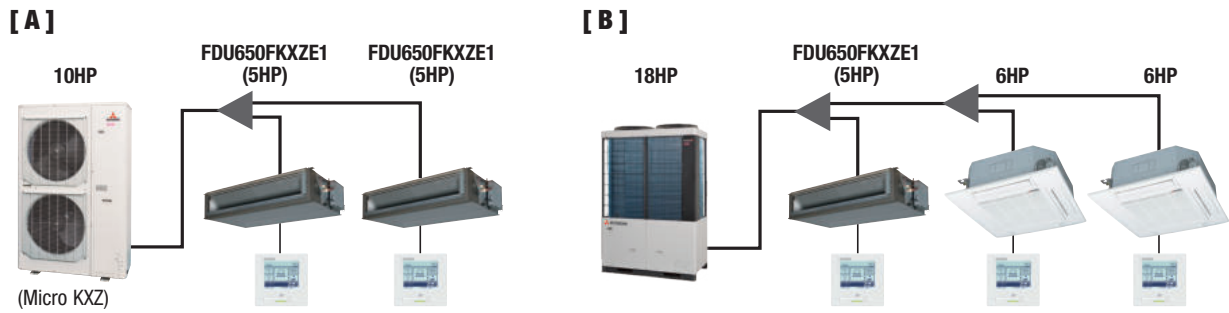

### Concept (Difference between FDU-F and SAF)

SAF is the energy recovery ventilation unit which can recover heat energy from exhaust air to supply air and "has no air processing function, but FDU-F is an air processing unit which can treat the supply air closer to room temperature by cooling or heating in connection with KXZ refrigerant system and exhaust air is discharged to outside of the room.

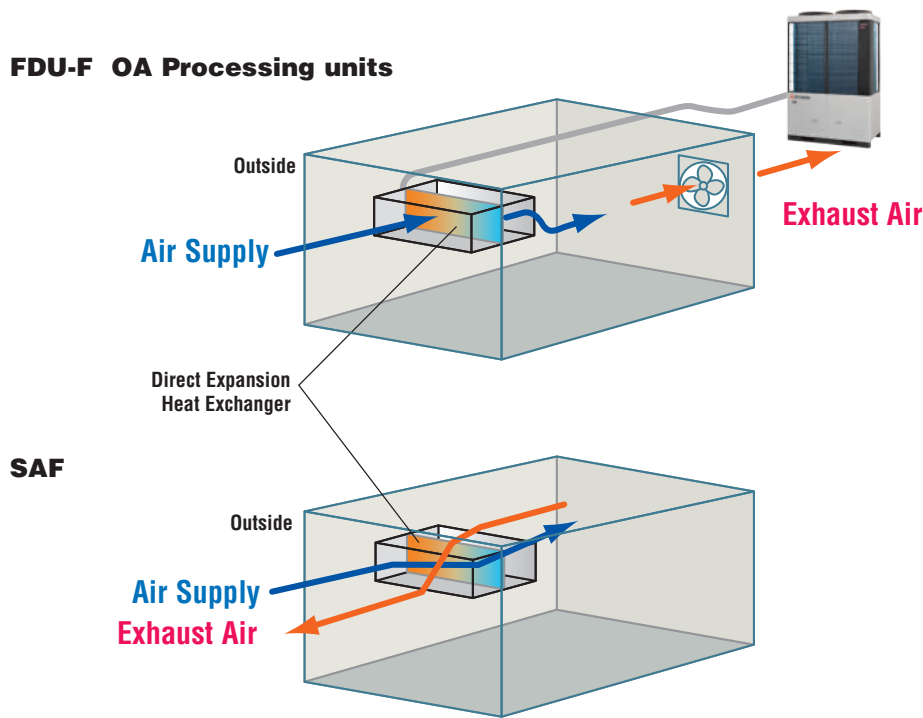

### SPECIFICATIONS

Indoor unit	FDU		650FKXZE3-W	1100FKXZE3-W	1800FKXZE3-W	2400FKXZE3-W	650FKXZE1	1100FKXZE1	1800FKXZE1	2400FKXZE1		
Power source	1 Phase 220-240V, 50Hz											
Nominal capacity	Cooling	kW	9.0	14.0	22.4	28.0	9.0	14.0	22.4	28.0		
	Heating		5.3	8.5	14.1	19.0	6.5	10.5	16.0	21.5		
Power consumption	Cooling	W	240-250	350-360	1160-1200		240-250	350-360	1160-1200			
	Heating											
Sound power level <sup>1</sup> (Hi)	Cooling	dB(A)	55	62	68	70	55	62	68	70		
	Heating											
Sound pressure level <sup>1</sup> (Hi)	Cooling	dB(A)	31	37	42	45	31	37	42	45		
	Heating											
Exterior dimensions (H × W × D)	mm		280 × 950 × 635	280 × 1368 × 740	379 × 1600 × 893		280 × 950 × 635	280 × 1368 × 740	379 × 1600 × 893			
Net weight	kg		34	54	89		34	54	89			
Air flow (Hi)	Cooling	m <sup>3</sup> /min	11	18	30	40	11	18	30	40		
	Heating											
Static pressure	Pa		200(at Hi Air flow)									
Outside air intake			Possible									
Refrigerant Type			R32				R410A					
Refrigerant piping size	Liquid	mm (in)	ø9.52(3/8")(Flare)		ø9.52(3/8")(Brazing)		ø9.52(3/8")(Flare)		ø9.52(3/8")(Brazing)			
	Gas		ø15.88(5/8")(Flare)		ø19.05(3/4")(Brazing)		ø22.22(7/8")(Brazing)		ø15.88(5/8")(Flare)		ø19.05(3/4")(Brazing)	
Refrigerant			R32				R410A					
Air filter			Procure locally									

- The data are measured at 33°CDB 28°CWB (68%RH) during cooling and 0°CDB -2.9°CWB (50%RH) during heating (no frost).
- Temperature range of outdoor air must be 20-43°CDB (32°CWB or less) during cooling and -10°C to 24°CDB during heating; for R32 refrigerant.
- Temperature range of outdoor air must be 20-40°CDB (32°CWB or less) during cooling and -10°C to 24°CDB during heating; for R410A refrigerant.
- Sound level indicates the value in an anechoic chamber. During operation these value are somewhat higher due to ambient conditions.
- The factory E.S.P. setting is set within the range of 10-120Pa. When SWB-4 is turned to "ON", E.S.P. setting range can be changed to 10-200Pa. (for RC-EX3D and RC-E5 only).

# Hydro Module unit HMU



HMU140 · 280

## Remote control (Option)

Wired



RC-EX3H

## What is the hydro module unit? (Hydro module unit : HMU)

This unit is an auxiliary device for use with the VRF type multi systems to control water temperatures.

It employs the plate heat exchanger in place of fin heat exchanger, and produces cold or hot water by exchanging heat between refrigerant and water. Since it can produce hot or cold water using the VRF type multi systems as the heat source, it allows to configure a chiller system in a simple way on the one hand. On the other, it can expand the range of applications of air-conditioner because it can be used mixed with the multiple indoor unit for building.

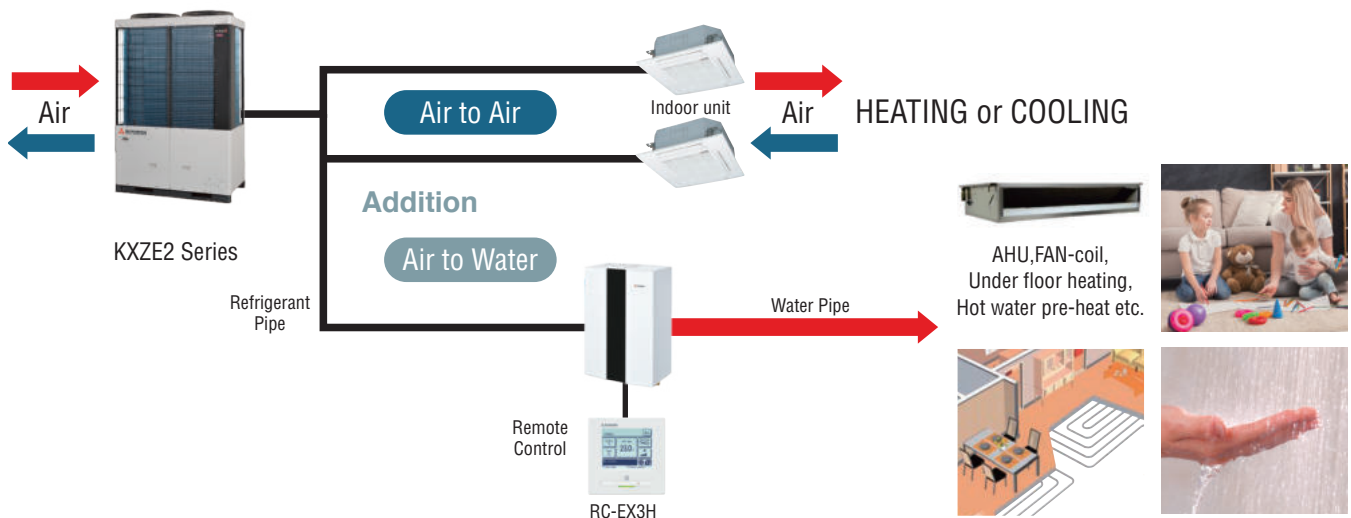

### Target outlet water temperature constant control

- This is achieved by controlling compressor frequency and control of EEVs.
- Controlling the capacity of HMUs in accordance with the load.
- The HMU is designed to achieve a hot water temperature of 55°C.

### Mixed operation

- Mixed operation is possible in the air to air indoor unit and HMU.
- During the operation only of HMU, it can accommodate a wide range of outlet water temperature controlled by a dedicated control.
- When the system is in mixed operation, the HMU or air-conditioner can be set as priority.

### Antifreeze control

- Anti-freeze protection of plate heat exchanger is enabled during defrost operation.

### External equipment linked

- External output of interlocking signal to an external heat source for the secondary heating.
- Possible target setting temperature change from the external input. (3 points)
- Water pump control (ON / OFF) possible.

\*HMU is designed for closed loop heat exchange applications. Connections to any other open loop systems (such as domestic water) should be handled via a secondary heat exchanger.

# Application example

Heating system using HMU and air-conditioner propose various solutions.



## SPECIFICATIONS

Indoor unit		HMU	140KXZE1	280KXZE1
Power source			1 Phase 220-240V, 50Hz	
Deviation, incoming supply			± 10%(Min.85% at starting)	
Operation range	Maximum capacity	Cooling	14	28
		Heating		
	Power consumption (Rated/Max.)	Cooling	220/360	316/360
		Heating		
	Current (Rated/Max.)	Cooling	1.00-0.92/1.54	1.44-1.32/1.54
		Heating		
	Outdoor temperature	Cooling	15-46	
		Heating	-20-32(Mixed Use*1 : -20-20)	
	Indoor temperature		0-32(Without freezing)	
	Indoor relative humidity		≤ 90	
	Inlet water temperature	Cooling	12-30(Mixed Use*1 : 19-24)	
		Heating <sup>*2</sup>	20-50(Mixed Use*1 : 20-35)	
		Heating <sup>*3</sup>	25-50(Mixed Use*1 : 25-35)	
	Outlet water temperature	Cooling	7-25(Mixed Use*1 : 14-19)	
		Heating <sup>*2</sup>	25-55(Mixed Use*1 : 25-40)	
		Heating <sup>*3</sup>	30-55(Mixed Use*1 : 30-40)	
Water flow (Rated/Min.-Max.)		40/20-40	80/24-80	
External water pressure @Rated flow		98	80	
Allowable operating pressure (water)			30-600	
Minimum suction head at 50°C			30	
Inlet water pressure			30-600	
Sound power level	Cooling <sup>*4,6</sup>		48	
	Heating <sup>*5,6</sup>	46	49	
Sound pressure level	Cooling <sup>*4</sup>		32	
	Heating <sup>*5</sup>	27	31	
Exterior dimensions (HxWxD)		860(110*7) x 550 x 400		
Weight (without water)		46	48	
Weight (Including water)		47.8	50.6	
Minimum amount of water in the water circuit		L	230	
Set pressure of safety valve			600	
Water pipe connection			R1-1/2	
Refrigerant Type			R410A	
Refrigerant piping size	Liquid	mm	ø9.52(3/8" ) (Flare)	
	Gas	(in)		ø22.22(7/8" ) <sup>*8</sup> (Brazing)

\*1 Mixed use means HMU and air to air indoor unit mixed operation. \*2 In case outdoor temperature more than 0°C.(0°C<Outdoor air temperature ) \*3 In case outdoor air temperature is 0°C or less. (Outdoor temperature ≤ 0°C) \*4 Sound test condition for cooling: Cooling condition 1. \*5 Sound test condition for heating: Heating condition 3. \*6 MIC position: 1m from the center of the HMU.

\*7 Outside piping length. \*8 Accessory pipe needs to be connected for gas pipe on site.

• The unit is compatible with the KXZ2 series and the previous KXZK1 series. For details, please refer to the technical documents.

## Performance data

Indoor unit		HMU280KXZE1	
Outdoor unit		FDC280KXZE2	
Heating nominal capacity	condition 1	kW	23.00
	condition 2		23.15
	condition 3		25.20
Heating power consumption	condition 1	kW	8.40
	condition 2		6.90
	condition 3		6.00
COP	condition 1	-	2.74
	condition 2		3.36
	condition 3		4.20
ηsh	condition 3 base		151
Cooling nominal capacity	condition 1	kW	25.80
	condition 2		18.80
Cooling power consumption	condition 1	kW	6.35
	condition 3		6.25
	condition 2		4.06
EER	condition 1	-	3.01
	condition 2		3.01

Note: Heating condition 1: Inlet/outlet water temp. 47°C/55°C, Outdoor temp. 7°CWB/6°CDB. Heating condition 2: Inlet/outlet water temp. 40°C/45°C, Outdoor temp. 7°CWB/6°CDB.

Heating condition 3: Inlet/outlet water temp. 30°C/35°C, Outdoor temp. 7°CWB/6°CDB.

Cooling condition 1: Inlet/outlet water temp. 23°C/18°C, Outdoor temp. 35°CWB/- . Cooling condition 2: Inlet/outlet water temp. 12°C/7°C, Outdoor temp. 35°CWB/- .

# Ventilation

## Fresh Air Ventilation and Heat Exchange unit

### SAF-E7



SAF smart technology recovers heat energy in the atmosphere which would have otherwise been lost. It then uses this energy to warm air entering the building. The reverse happens in warmer climates where the exhausted cool air is used to partially cool the incoming air.

Helping you to reduce energy consumption and carbon emissions by capturing waste energy.



Switch box (Option)

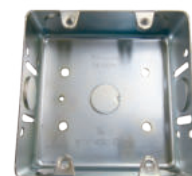

#### Remote control

The following functions are newly available.

- ON/OFF Timer – The hour and minute of timer on/off can be set.
- Filter Sign – Announces the due time for cleaning the air filter.

#### Increased external static pressure at UHi air flow

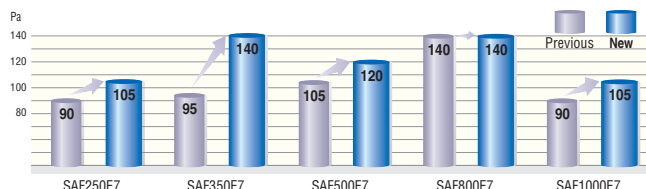

#### Principle of Operation

Principle of operation (simple ventilation)

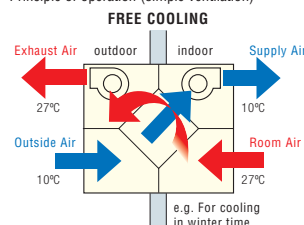

Principle of operation (heat exchanging)

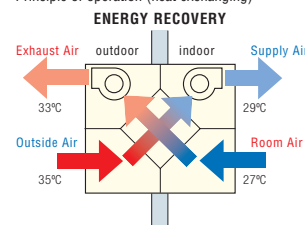

## SPECIFICATIONS

Indoor unit	SAF	150E7	250E7	350E7	500E7	800E7	1000E7		
Power source	1 Phase 220-240V, 50Hz								
Exterior dimensions (HxWxD)	mm	270x970x467	270x882x599	317x1050x804	317x1090x904	388x1322x884	388x1322x1134		
Exterior appearance	Galvanized steel sheet								
Power input	W	92-107	108-123	178-185	204-225	360-378	416-432		
Running current	A	0.42-0.45	0.49-0.51	0.81-0.77	0.93-0.94	1.64-1.58	1.89-1.80		
Capacity	UHi	Enthalpy exchange efficiency	Cooling	63				65	
			Heating	70				71	
		Temperature exchange efficiency	75						
	Hi	Enthalpy exchange efficiency	Cooling	63				65	
			Heating	70				71	
		Temperature exchange efficiency	75						
	Lo	Enthalpy exchange efficiency	Cooling	66	65	71	64	68	70
			Heating	73	72	73	69	74	76
		Temperature exchange efficiency	77		78	76		79	
Motor & Q'ty	W	10 × 2	20 × 2	40 × 2	70 × 2	180 × 2	180 × 2		
Air handling equipment Fan type & Q'ty	Sirocco fan x 2								
Air flow (UHi/Hi/Lo)	m <sup>3</sup> /h	150/150/120	250/250/190	350/350/240	500/500/440	800/800/630	1000/1000/700		
External static pressure (UHi/Hi/Lo)	Pa	80/70/25	105/95/45	140/60/45	120/60/35	140/110/55	105/80/75		
Net weight	kg	25	29	49	57	71	83		
Air filter	Supply air Exhaust air	Protection for element (Washable) PS400							

(1)The data are measured at the following conditions.

		Summer	Winter
Indoor side (Supply air)	DB	27°C	20°C
	WB	20°C	14°C
Outdoor side (Outside air)	DB	35°C	5°C
	WB	29°C	2°C
Unit around	DB	27°C	20°C

# Fresh Air DX Assembly SAF-DX



**Drain up kit (Option)**  
DXA-DU-E  
(Built-in type)

**Remote control (Option)**

Wired



**RC-E5**

Wireless



**RCN-KIT4-E2**

- SAF-DX is a heating or cooling coil incorporating KXZ series controls. It can be used in combination with our total heat exchanger. (SAF series)
- Combination of SAF-DX with other indoor units is possible. The capacity code index of each model is shown below and must be used when making the system selection. Total capacity code index must be within 100% of outdoor unit capacity code index.
- Remote control option is the same as other indoor units (see above). Connection to all Superlink controls is also possible.
- Optional condensate lift mechanism is also available (600mm height).
- Return air temp. control or supply air temp. control can be selected.

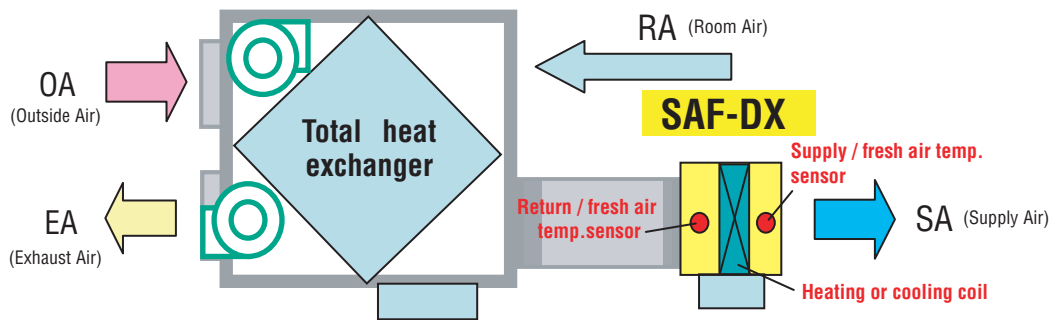

SAF-DX can provide heating or cooling to the fresh air supplied through a 3rd party air handling unit or total heat exchanger such as our SAF series.

## ■ SPECIFICATIONS

Indoor unit	SAF-DX	250E6	350E6	500E6	800E6	1000E6
Power source		1 Phase 220-240V, 50Hz				
Nominal capacity	Cooling	2.0	2.8	3.6	5.6	6.3
	Heating	1.8	2.2	2.8	4.5	5.6
Capacity code		22	28	36	56	71
Power consumption	Cooling	7.2-7.2				
	Heating	7.2-7.2				
Running current	Cooling	0.05-0.05				
	Heating	0.05-0.05				
Exterior dimensions (H × W × D)	mm	315 × 452 × 422		315 × 537 × 422	315 × 682 × 422	315 × 822 × 422
Net weight	kg	12.3		13.6	16.1	18.4
Air flow (Standard)	m <sup>3</sup> /h	250	350	500	800	1000
Internal resistance	Pa	38	66			
Refrigerant Type		R410A				
Refrigerant piping size (Flare)	Liquid	ø6.35(1/4")				ø9.52(3/8")
	Gas	ø9.52(3/8")		ø12.7(1/2")		ø15.88(5/8")

(1)The data are measured at the following conditions.

Item	Return/fresh air temperature		Outdoor air temperature		Standard
	DB	WB	DB	WB	
Cooling*1	27°C	19°C	35°C	24°C	ISO-T1
Heating*2	20°C		7°C	6°C	

(2)The air-conditioner is manufactured and tested in conformity with ISO-T1 "UNITARY AIR-CONDITIONERS".

# Electronic Expansion Valve Kit

## EEV-KIT



- EEV-KIT is the control kit for operating the locally provided AHU or FCU with direct expansion heat exchanger coils in connection with the KXZ system.  
(AHU : Air Handling Unit, FCU : Fan Coil Unit)
- EEV-KIT is composed of one EEV-Control ASSY and one EEV-Set.

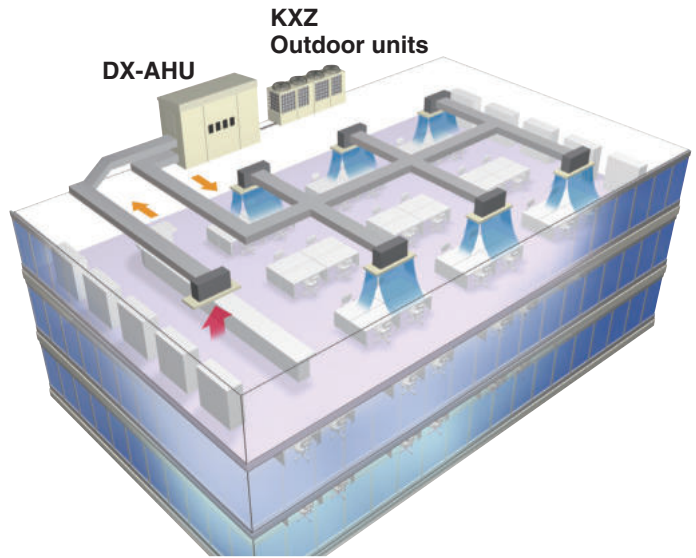
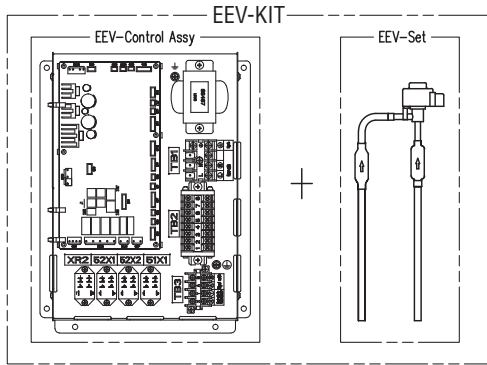

DX : Direct expansion coil

\* The unit is not compatible with heat recovery systems or R32 units. For details, please refer to the technical documents.

## Features

EEV-Control Assy has 2 types.

Refrigeration system	EEV-Control Assy	
	EEVKIT6-E-M	EEVKIT6-E-C
Single		1 box-Many boxes
Multiple	1 box (for master)	Many boxes(for slave)

EEV-Set Select from following 3 types according to the coil capacity.

Type	EEV6-71-E	EEV6-160-E	EEV6-280-E
Capacity	22-71	90-160	224-280

## System configuration

- Single refrigeration system EEVKIT6-E-C ... Possible with multiple refrigeration systems
- Multiple refrigeration system EEVKIT6-E-M (1) + EEVKIT6-E-C ... Possible with multiple refrigeration systems(Max32)
- EEVKIT6-E-C is common for both single and multiple refrigeration systems

## Single refrigerant system

- Single refrigeration system is the one that can have multiple outdoor units on one refrigerant pipe work circuit.
- There are 2 types of EEV-KIT systems that can be built into the single refrigeration system.
- System A : one EEV-KIT.
- System B : multiple EEV-KIT's.

### System A

- This system has only one set of EEV-KIT built into one indoor unit with only one heat exchanger. This system can be applied to an indoor unit whose capacity is up to 10HP.

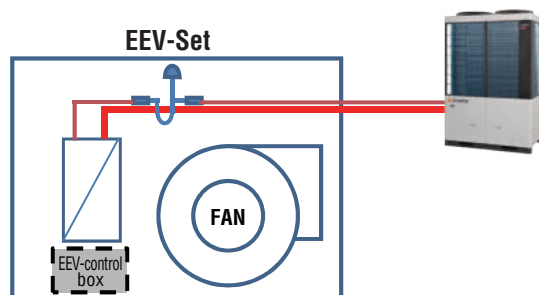

### System B

- System B is a system that has multiple EEV-KIT's built into one indoor unit with multiple heat exchangers on one refrigerant circuit.
- This system can be applied up to 60HP (for KXZ) AHU capacity.

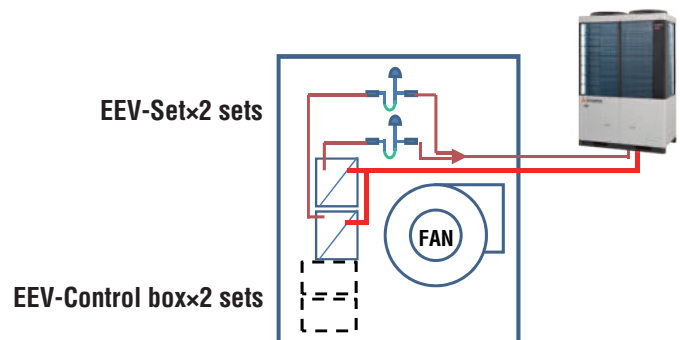

# Multiple refrigerant system

Multiple refrigeration system is an AHU system with multiple independent refrigerant circuits and one master control to control the whole system.

## Advantages

- Large systems are possible [max capacity 896kW ]
- External control
- Capacity step control
- Can connect to 32 units

## Additional parts over a single refrigeration system

- One master control
- The slave EEV control and EEV set are the same as a single refrigeration system.

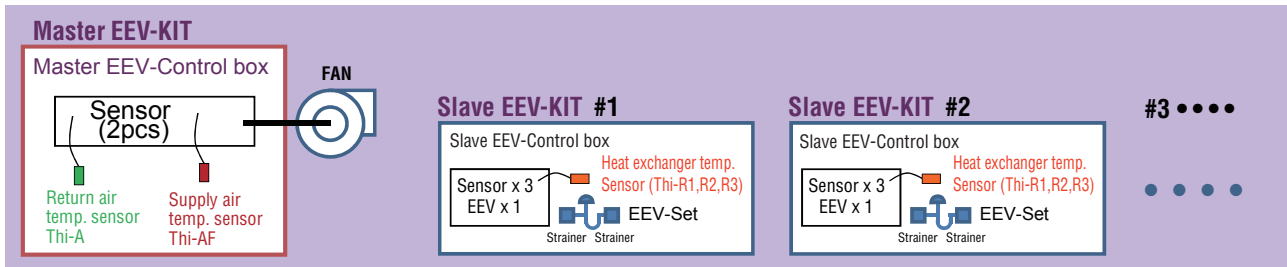
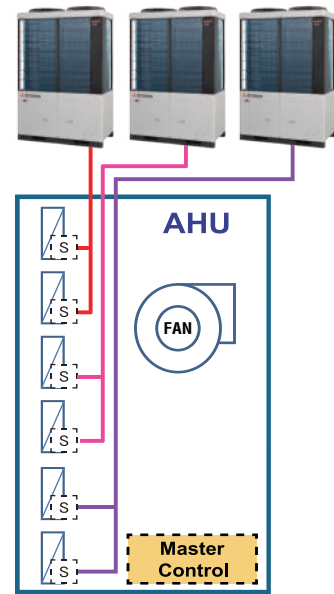

# Connection to SUPERLINK-II

## Single refrigeration system

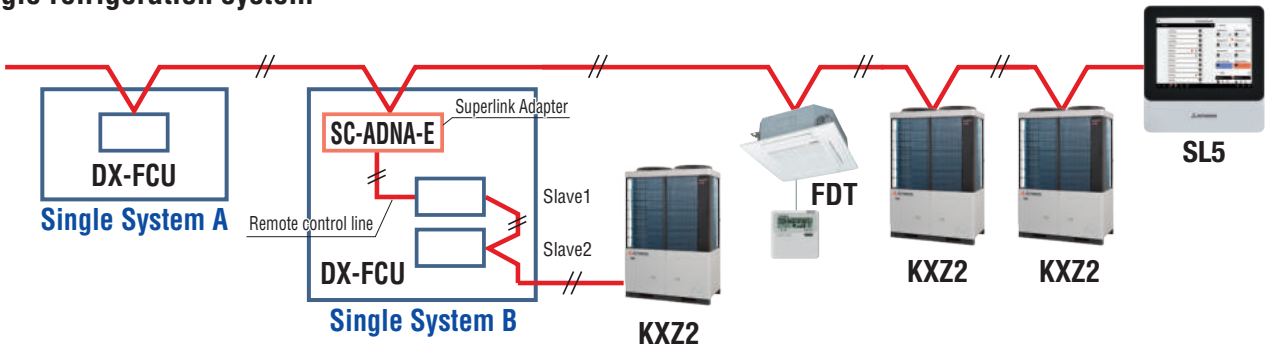

## Multiple refrigeration system

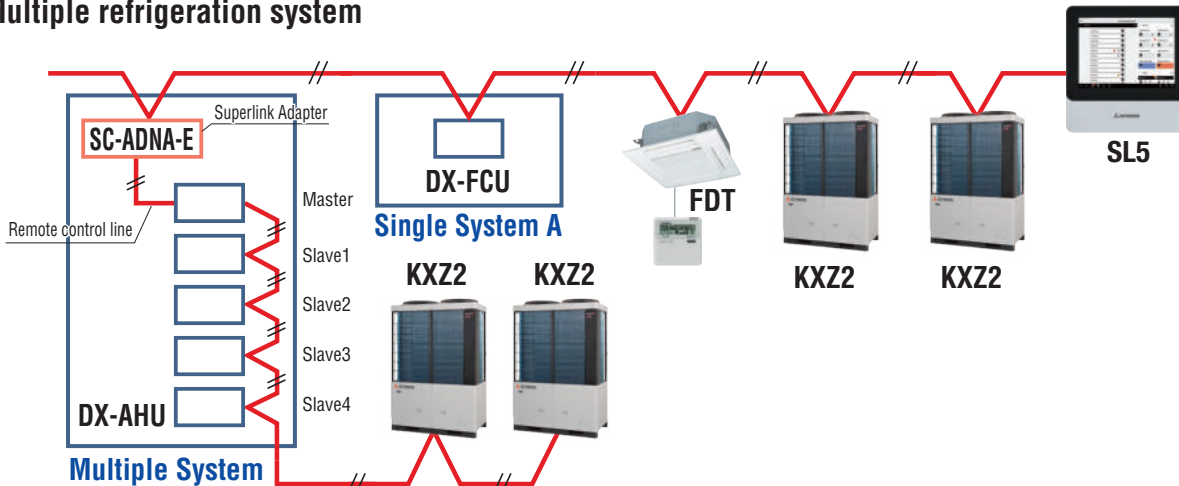

# Control Systems

## Individual control

### Remote Control line up

Wired	Indoor unit	Remote control	Wireless	Indoor unit	Remote control	Indoor unit	Remote control	Indoor unit	Remote control
	All models	RC-EX3D		RC-E5	FDT	RCN-T-5BW(-5BB)-E2	FDT5	RCN-TS-E2	FDE
		RC-E51	FDTC	RCN-TC-5AW-E3	FDK22-56	RCN-K-E2	FDWF	RCN-FW-E2	
			FDTW	RCN-TW-E2	FDK71	RCN-K71-E2	Others*	RCN-KIT4-E2	

\*FDTQ, FDU, FDUM, FDUT, FDUH, FDU-F

Wired remote control

(Option)

### RC-EX3D H120 × W120 × D19 mm

### Intuitive touch controller with Liquid Crystal Display

#### User friendly

- LCD panel with light tap operation introduced as the industry's first
- Simple interface with only three buttons

#### Easy view

- Big LCD with 3.8 inch full dot display
- Back light function
- Multi language display (9 languages)

**Operation mode**

- Cooling
- Fan
- Dry
- Heating
- Auto

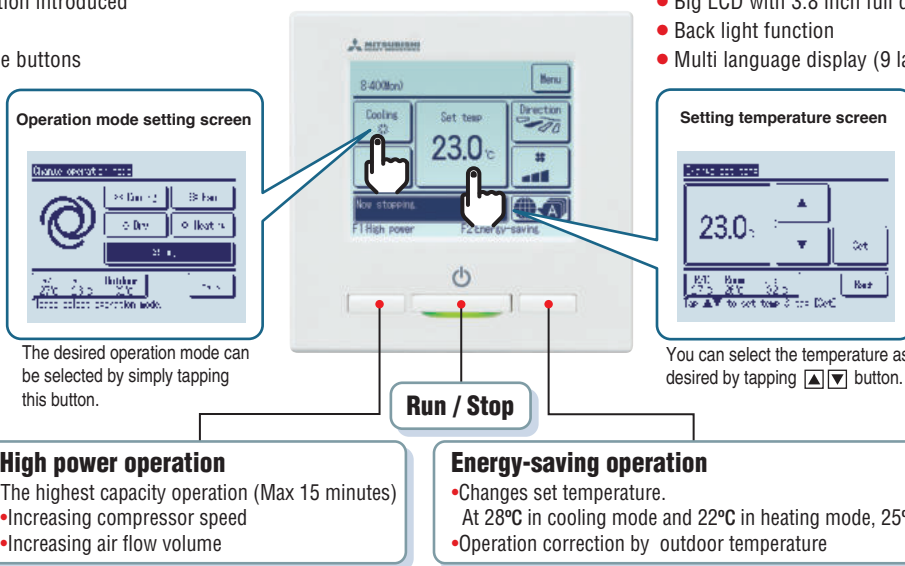

### Main functions

	Function name	Description
Economy & Timer	Energy-saving operation	Since the capacity is controlled automatically based on the outdoor temperature, energy can be saved without losing comfort.
	Sleep timer	Set the time period from start to stop of operation. The selectable range of setting time is from 30 to 240 minutes (at 10 minute intervals).
	Set temperature auto return	The temperature automatically returns to the previously set temperature.
	Set ON timer by hour	When the set time elapses, the air-conditioner starts.
	Set OFF timer by hour	When the set time elapses, the air-conditioner stops.
	Set ON timer by clock	The air-conditioner starts at the set time.
	Set OFF timer by clock	The air-conditioner stops at the set time.
	Weekly timer	On or Off timer can be set on a weekly basis.
	Peak-cut timer	Capacity control can be set by using peak cut function on RC-EX3D for better energy saving. Five-step capacity control is available.
	Home leave operation	When the unit is not used for a long period of time, the room temperature is maintained at a moderate level, avoiding extremely hot or cool temperatures.
Comfort	Big LCD & Touch screen panel	Large 3.8 inch screen has resulted in improved visibility and operability.
	Easy modification of Individual flap control	User can visually confirm and set the direction of flaps using the visual display on the remote controller.
	Automatic fan speed *1	The micro-computer automatically adjusts the air flow effectively to follow the changes of return air temperature.
	Temp increment setting	Temperature increment for the change of the set temp can be changed.
Convenience	Silent mode	Set the period of time to operate the Outdoor unit with prioritizing the quietness.
	Function switch	The function switch allows user to select and set two functions among available functions.
	Favourite setting	Operation mode, set temperature, fan speed and air flow direction automatically adjust to the programmed favourite setting.
	Adjusting Brightness of the background light	The brightness of the background light can be adjusted by 10 stages.
	LCD contrast setting	This function allows user to adjust LCD display contrast.
	High power operation	High Power Mode increases the unit operating ability for 15 minutes to quickly adjust the room temperature to a comfortable level.
	Back light setting	This convenient function allows user to see controls under low light conditions.
	Administrator settings	This function only allows specific individuals to operate the unit.
	Setting temp range	Limited range of setting temperature in the heating or the cooling operation can be selected.
	External Input/Output Function	The external input/output of indoor unit by remote controller can set input/output based on user needs.
Service	Select the language	Set the language to be displayed on the remote control.
	Error code display	This function allows user to check information displayed when abnormal function of the unit occurs.
	Operation data display	Displays various types of air-conditioner operation data in real time.
	Contact company display	Address of the service contact is displayed.
	Filter sign	Announces the due time for cleaning of the air filter.
	Static pressure adjustment	Allows user to adjust duct static pressure using the remote control.
Backup Control	Allows for rotation control, fault backup control, and capacity backup control.	

\*1 Cannot be used when a centralized control remote is connected.

**Wireless remote control**

**(Option)**

For wireless control simply insert the infra-red receiver kit on a corner of the panel

**RCN-T-5BW-E2**  
**RCN-T-5BB-E2**



**RCN-TC-5AW-E3**



**RCN-TW-E2**



**RCN-TS-E2**



**RCN-K-E2,**  
**RCN-K71-E2**

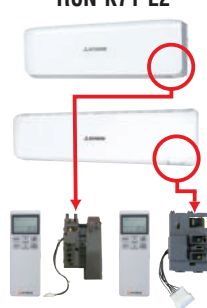

**RCN-E-E3**



**RCN-FW-E2**



**RCN-KIT4-E2**



\*The wireless remote control is not applicable to the Individual flap control system.

**Design remote control**

**(Option)**

**RC-ES1 (wired) New**

H86 × W86 × D17 mm

- Simple and sophisticated design
- Compact size (86 × 86 mm)
- Remote control with Bluetooth® wireless technology



**Wireless connection**



reddot winner 2025



A' DESIGN AWARD  
WINNER 2025  
GOLD

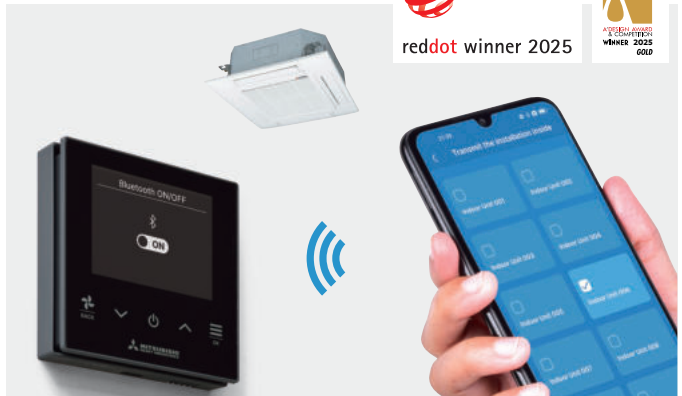

Remot control with Bluetooth® wireless technology. Easy set-up of indoor units.

Notifications of abnormal conditions or operational data from the remote control will be sent to your smartphone.

The Bluetooth® word mark and logos are registered trademarks owned by Bluetooth SIG, Inc. and any use of such marks by MITSUBISHI HEAVY INDUSTRIES THERMAL SYSTEMS, LTD. is under license.

**Wired remote control**

**(Option)**

**RC-E5** H120 x W120 x D19 mm



The RC-E5 controller enables extensive access to service and maintenance technical data combined with easy to use functions and a clear LCD display.

**Weekly timer function as standard**

RC-E5 provides (as a standard feature) a weekly timer, which allows one-week operation schedules to be registered. A user can specify up to four times a day to start/stop the air-conditioner. (Temperature setting is also possible with the timer).

**Run hour meters to facilitate maintenance checking**

RC-E5 stores operation data when an anomaly occurs and indicates the error on the LCD. It also displays cumulative operation hours of the air-conditioner and compressor since commissioning.

**Room temperature controlled by the remote control sensor**

The temperature sensor is housed in the top section of the remote control unit. This arrangement has improved the sensitivity of the remote control unit's sensor, which permits more finely controlled air-conditioning.



**Changeable set temperature ranges**

RC-E5 allows the upper and lower limits of a set temperature range to be specified separately. By adjusting a set temperature range, you can ensure energy saving air-conditioning by avoiding excessive cooling or heating.

**Thermistor**

**(Option)**

**SC-THB-E3**

In case the sensor integrated in the indoor unit or in the remote controller is unable to sense the room temperature correctly, or an individual controller in each room is not required but a temperature sensor is (as when a central control system is in place), install SC-THB-E3 in an adequate location in the room.



# Controls network overview

Our company offers simplicity in installation with the highly sophisticated SUPERLINK-II Control System

**This offers building owners and occupiers** a comprehensive control and management system while providing complete commissioning and service maintenance assistance for installers and service engineers. The SUPERLINK-II is an advanced high speed data transmission system which can connect up to 128 indoor units and 32 outdoor units onto one network. A wide range of control options are available for the SUPERLINK-II network to suit any application large or small, as well as connection to a new or existing Building Management System (BMS).

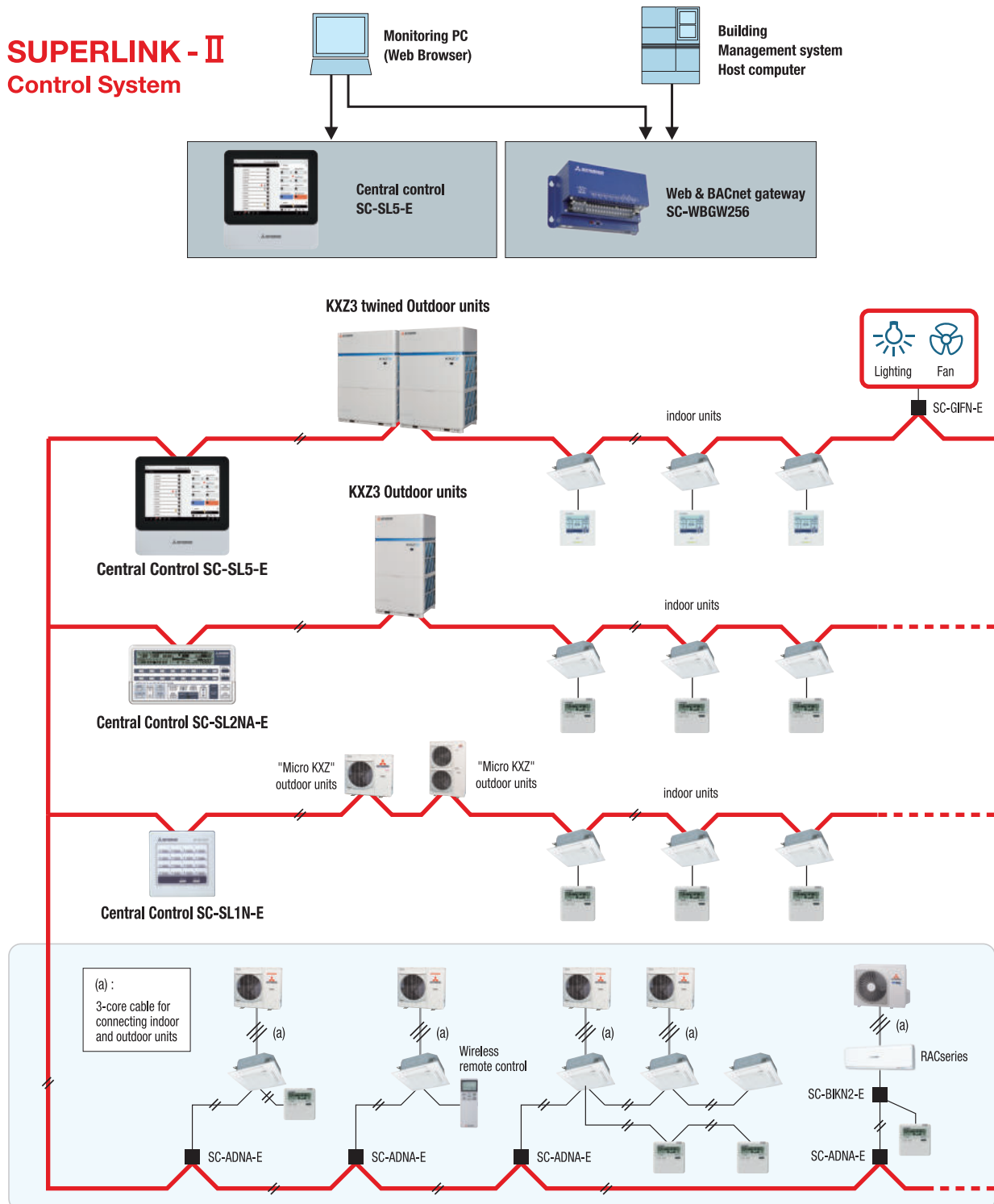

# Central Control

## SC-SL1N-E

Start/stop control of up to 16 indoor units either individually or collectively.  
Simple centralised control.

1. The SC-SL1N-E is connected to the Superlink- II network via 2-core, non-polar wires ('AB' connection).
2. It will monitor and control the start/stop function of up to 16 units, with the sixteen operation button.
3. The unit or group numbers in operation or in need of service are displayed with an LED.
4. Collective start/stop is also available through the simultaneous on/off button.
5. Up to 12 SC-SL1N-E units can be connected to a Superlink- II network (consisting of up to 128 indoor units).
6. If a power failure occurs, the SC-SL1N-E will resume the operation of the system according to a stored operation condition, once power is restored.



## SC-SL2NA-E

Central control of up to 64 indoor units including weekly timer function as standard.

1. The SC-SL2NA-E is connected to the Superlink- II network via 2-core, non-polar wires ('AB' connection).
2. It will monitor and control the start/stop function of up to 16 units, or 16 groups of units, with the sixteen operation buttons.
3. It also monitors and controls the following functions for individual units, groups of units or the complete network: operation mode, set point temperature, return air temperature, louver position, error code. Air flow and center lock function.
4. The unit or group numbers in operation or in need of service are displayed with an LCD.
5. Collective start/stop is also available through the simultaneous on/off button.
6. If a power failure occurs, the SC-SL2NA-E will resume the operation of the system according to a stored operation condition, once power is restored.
7. The SC-SL2NA-E can be connected to an external timer to facilitate timed on/off cycles.

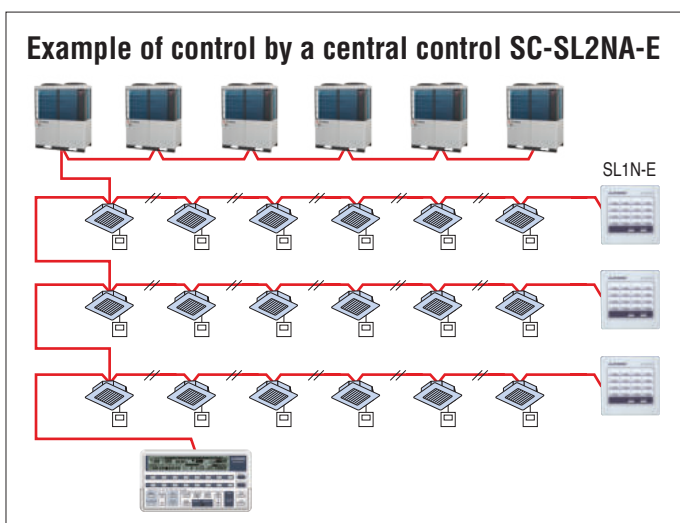
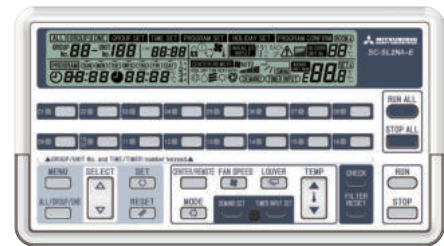

An SC-SL2NA-E performs the start/stop control, monitoring and mode setting of up to 64 units. It is a high quality air-conditioner control system that allows up to 64 indoor units to be freely grouped into 1 to 16 groups.

It allows not only the start/stop control but also the monitoring, display of operation statuses such as in operation or in need of service and mode setting such as switching of operation modes of connected units collectively, by group or individually.

- Outer dimensions: H120 x W215 x D25+35\* mm.
- 35\* is the measurement including the part contained in a recess.

### SC-GIFN-E Interface kit

- Applicable products  
Ventilation fan, Air purifier
- By using SC-GIFN-E together with central control such as SC-SL1N-E, SC-SL2NA-E and SC-SL5-E, you can start-stop, operate & monitor the operation of applicable products.

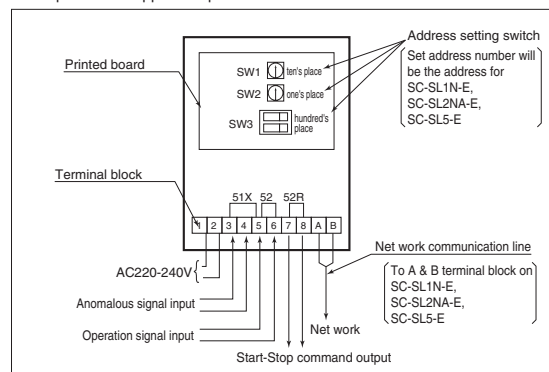

**Note:**Please consult dealer for combination of center controls and Building Management Systems interface units.

New

# Central Control SC-SL5-E

The easy-to-use, initiative interface and monochrome, modern appearance, along with the 10.4-inch Liquid Crystal Display, makes it the perfect solution for environments such as offices or hospitals.

For systems compatible with the SUPERLINK-II protocol, up to **256 units** can be connected.

\*For systems that support only the SUPERLINK protocol, a maximum of 96 units (48 units each SUPERLINK) can be connected.



## 10.4-inch Liquid Crystal Display

External dimensions (Height x Width x Depth)  
280mm x 264mm x 25/50 mm

Depth: (Wall-embedded / Wall-mounted)



## Specification

Item	SC-SL5-E	
Ambient temperature during use	0 – 40°C	
Power supply	1 Phase 100-240V 50/60Hz	
Power consumption	13W	
External dimensions (Height x Width x Depth)	280mm x 264mm x 25 (+25) mm	
Net weight	2.3kg	
Number of connectable units	Up to 256 units	
LCD touch panel	Colour LCD, 10.4 inches (264mm)	
Inputs	Signal	SUPERLINK (2 systems), SUPERLINK+ Modbus, and SUPERLINK+ RT Protocol
	Watt-hour meter pulse *	8-point, pulse width 80ms or more
	Emergency stop signal *	1 point, non-voltage a contact input continuous input (closed, forced stop)
	Demand signal *	2 point, non-voltage a contact input continuous input (closed, demand control)
Outputs	Operation	All units stop: Open / Any unit operating: Close
	Malfunction	Normal: Closed / Abnormal: Open
	Refrigeration leak detector	Normal: Closed Refrigerant leak: Open



\* Side power supply is DC 12V (10mA).

# System Diagram

- Two independent communication ports are provided (SL4 is equipped with a single port).
- Each port supports independent protocol selection (SUPERLINK / Modbus / RT), allowing up to nine possible combinations.

The SC-SL5-E is compatible with various types of MHI products, including the KX series, Q-ton, Hydrolution PRO and Hyozan.

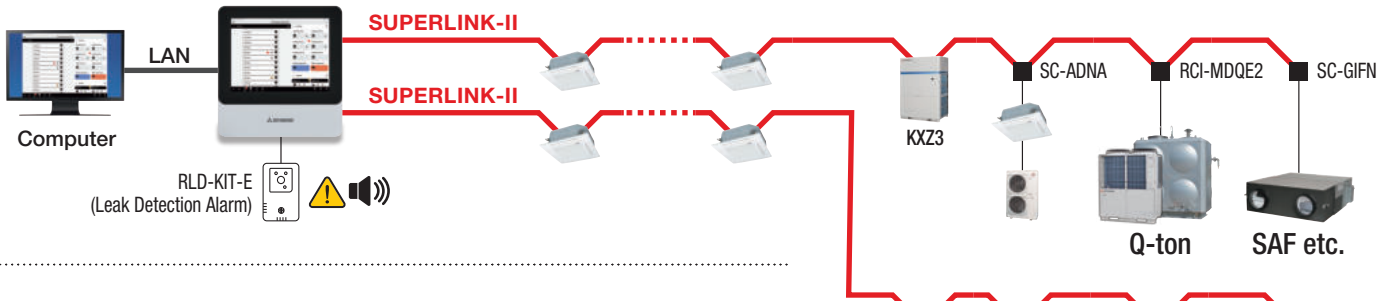

The SC-SL5-E or a computer connected LAN can now accurately monitor and control the Hydrolution PRO.

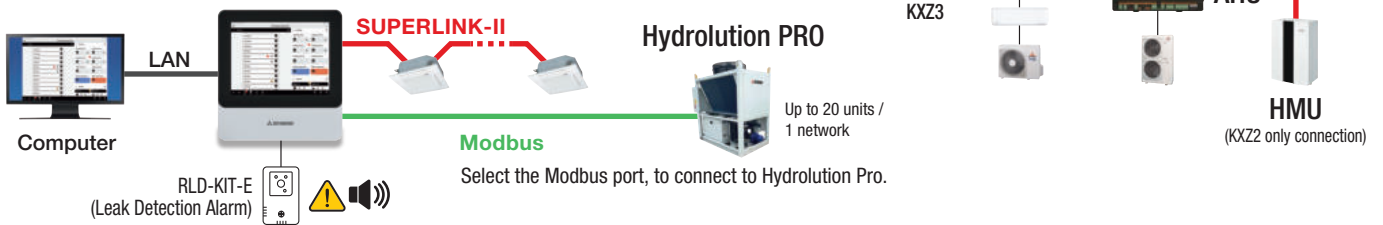

The SC-SL5-E or a computer connected LAN can accurately monitor Hyozan.

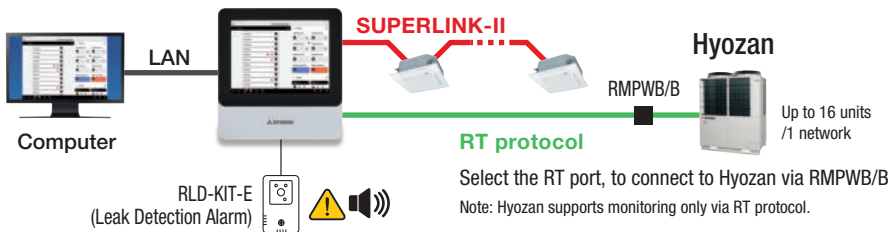

**SUPERLINK :**  
Max 48 units / 1 network

**SUPERLINK-II :**  
Max 128 units / 1 network

## Installation

Supports both wall-mounted and wall-embedded installation preferences. Both mounting brackets (flat metal plate and embedded frame) are included as standard, allowing for flexible on-site installation. The unit can be easily installed without removing the LCD panel.

### New Wall-mounted

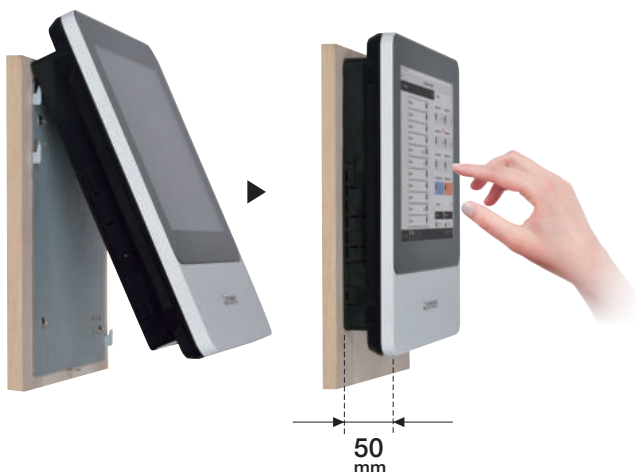

### Wall-embedded

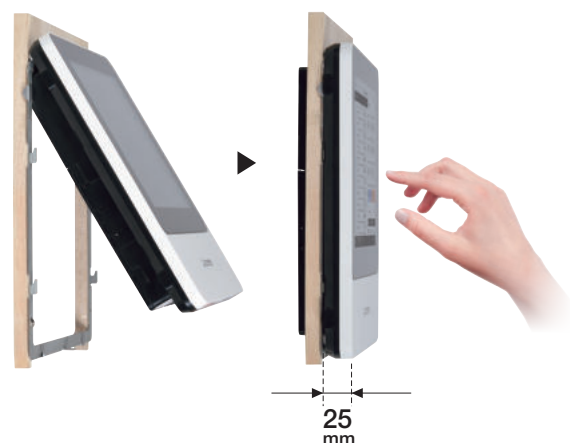

# New Screen Design & Usability

## Touch-Screen Technology

By adopting the same intuitive touch-screen technology as used in smartphones, fingertip operation is possible. For example, you can flick/swipe by touching screen. Additionally, the screen design allows for intuitive operation.



## Unified design across SC-SL5-E, PC web browser screen and M-ACCESS

The SL5 and PC web browser screen share the same dashboard, while M-ACCESS adopts a unified design concept with consistent fonts, colours, and icon styling - ensuring intuitive and seamless usability across the platforms.

## Seamless usability across the platforms



### Unified icon styling

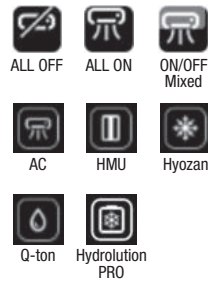

Note:

By setting the IP address, the controller interface can be displayed and operated on a PC.  
 Web browser requirements: Microsoft Edge, Google Chrome, Safari  
 Minimum monitor resolution: 1280x1024 or higher

## Scheduling

The RUN/STOP/AWAY time, operation mode, remote control Lock/Unlock setting, temperature setting, energy setting, and silent mode can be set up to 16 times per day.

In addition, the weekdays, holidays, special day 1, or special day 2\* can be selected and set. The system is also capable of automatically updating the annual schedule.

\*Special days refer to user-defined specific days.

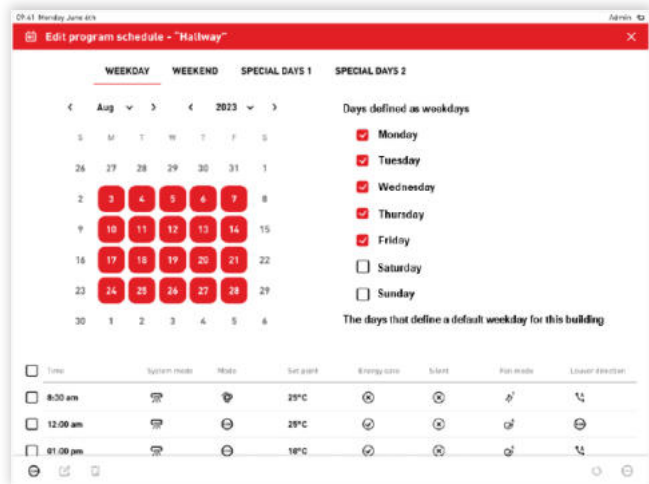

## Operational History

It is possible to review past operational usage for heating and cooling. Additionally, you can also check the usage of other modes such as the fan and dehumidification separately, allowing clear monitoring of power consumption and an easy breakdown by each operation mode.

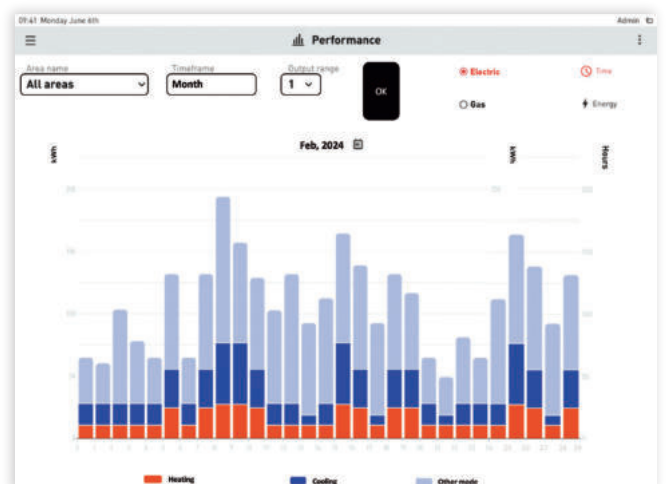

# Configuration of Block

Accurate control can be achieved by selecting various categories such as Block, Group or Floor.

Eg) If there are multiple businesses occupying separate floors, within one communal building, control can be managed separately for each business.

\*Note: Block allows ON/OFF operation only, while Group and Floor enable control of different device types.

## Unit icons and import floor layout

It is also possible to import your floor plan schematics in various formats (JPEG, PNG, BMP) and using the unit icon, position the units in the preferred locations. You may keep adjusting until you achieve your preferred installation layout.

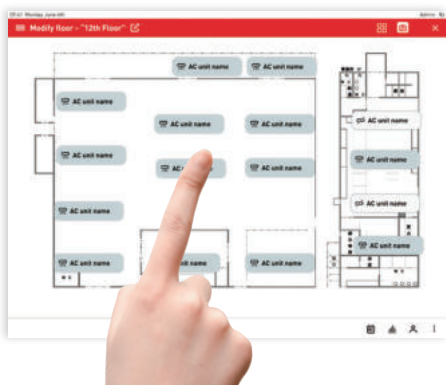

# New classification "Floor"

Units can be registered in both Group and Floor at the same time.

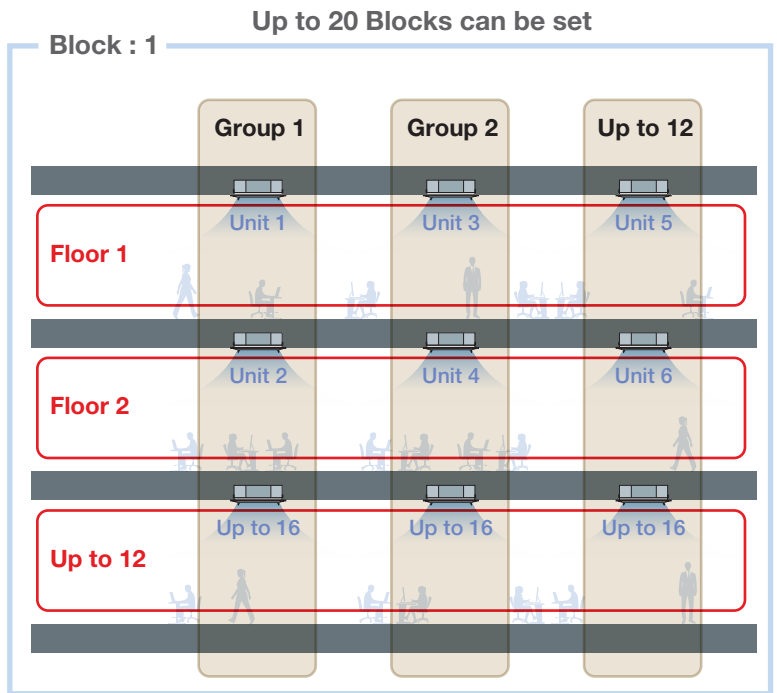

# Demand Control

## Temperature shift control

If the demand controller output sends a signal, the set temperature is automatically adjusted to save energy. The temperature shift value can be set in the setting screen.



## Peak cut control

If the demand controller output sends a signal, SL5 sends signal to the unit to adjust capacity. Capacity adjustments can be made via the setting menu.

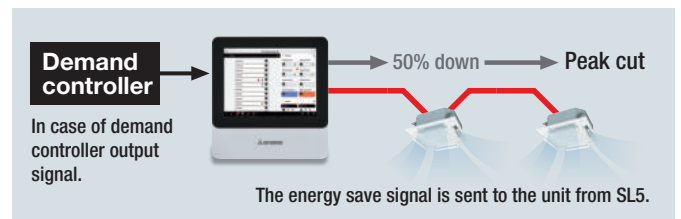

# Power Consumption & Billing Calculation

By connecting external watt-hour meters, SC-SL5-E collects power consumption data (kWh) for each indoor unit, each group, each SUPERLINK system and generates an automatic billing calculation\*. The unit includes standard billing functions, enabling the calculation of electricity rate tables and accounting time periods without the need for external software.

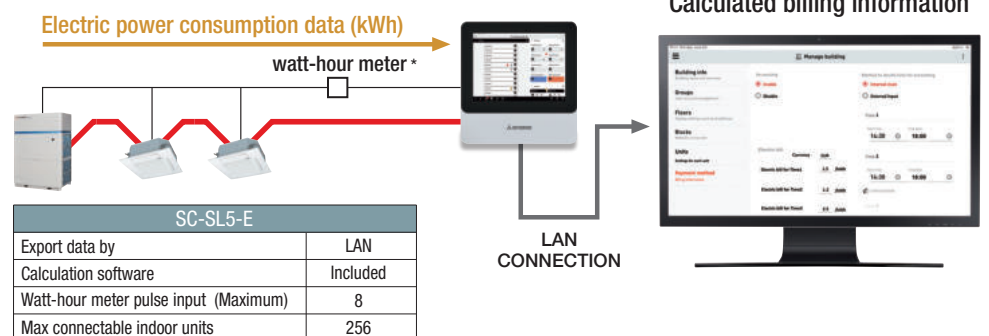

\* Relevant parameters must be set in advance.

\* The watt-hour meter is not included as a standard accessory and needs to be purchased separately, by the customer.

# IoT Remote monitoring system



**RM-CGW-E2** (H140 × W260 × D93mm)

The M-Access Cloud system is a remote monitoring solution for air-conditioning, leveraging IoT technology. The system supports the operation and management from both the software and hardware. The system could also be connected to products such as Q-ton / Hyozan / Hydrolyution PRO.

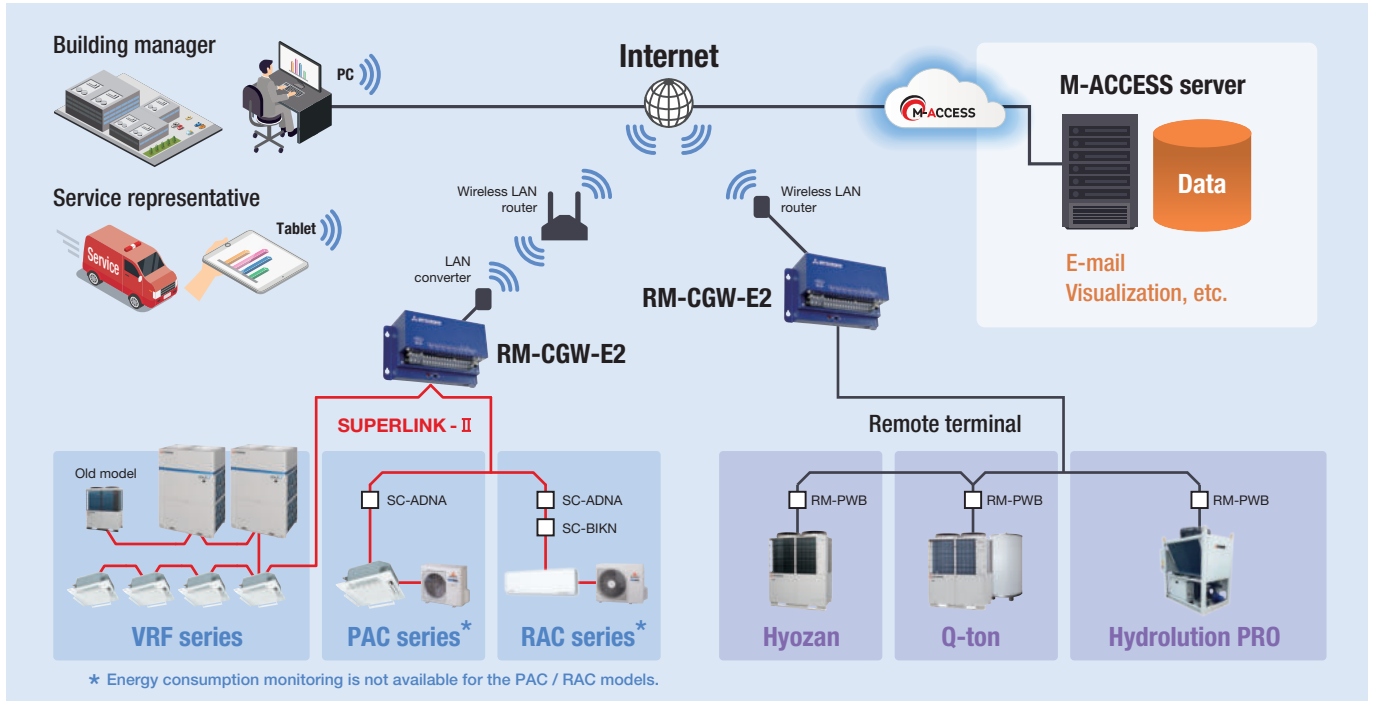

## Monitor and control units in various locations

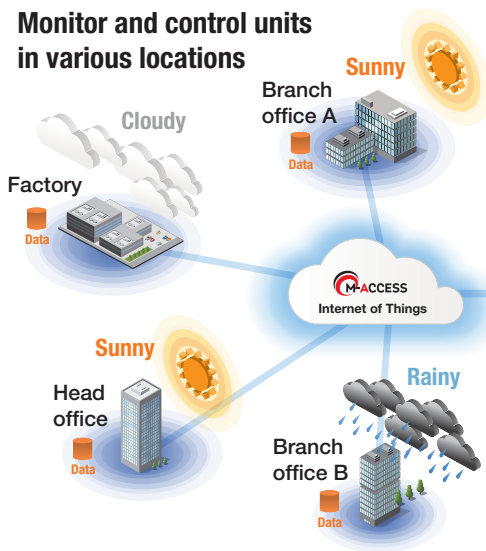

## From PC and tablets

Could monitor the conditions of the air-conditioning units in remote locations in real time.



The photos of the devices are an image

## The M-Access is a subscription-based service

The M-Access is a subscription-based service with an annual fee applicable only to specific areas. For details on pricing and payment methods, please consult your local installer. If the service is available in your area, the annual fee can be paid directly through the M-Access portal screen.

The screenshot shows a subscription payment form. On the left, there is a 'Subscribe to' section with a 'per year' dropdown, a 'billed annually' checkbox, a 'Subtotal' field, an 'Add promotion code' link, a 'WAT (5% inclusive)' field, and a 'Total due today' field. On the right, there is a 'Pay with card' section with an 'Email' field, a 'Card information' section with a VISA logo, a 'Cardholder name' field (TARO MITSUBISHI), a 'Country or region' dropdown (Japan), and a 'Subscribe' button.

# Energy Saving Control Function

Energy saving control function automatically controls air-conditioners to save energy based on the user's building profiles and power consumption target. Operation is automatically adjusted while maintaining comfort and taking into account weather conditions and past operations learnt by M-ACCESS's AI program.

### AI Demand Forecast

Predicts energy consumption based on operational data and weather forecasts

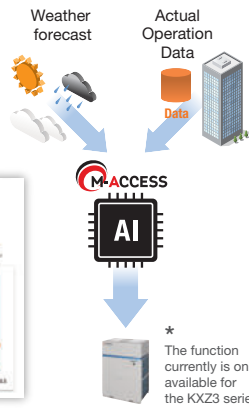

Energy saving control setting

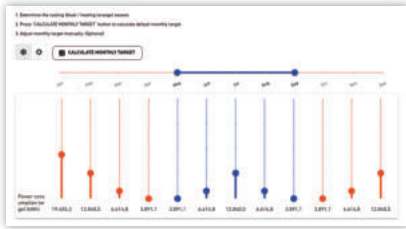

# Logic Control Function

Logic control function allows the user to preset actions that will be executed on targeted units and based on ambient or room temperatures. With the logic function, the air-conditioners automatically operate according to preset conditions set by the user.

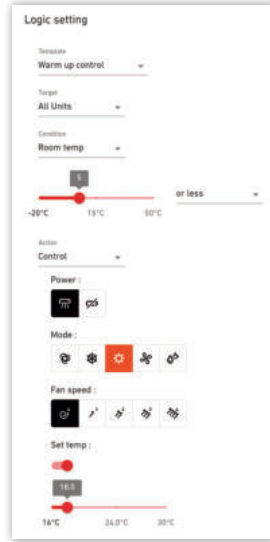
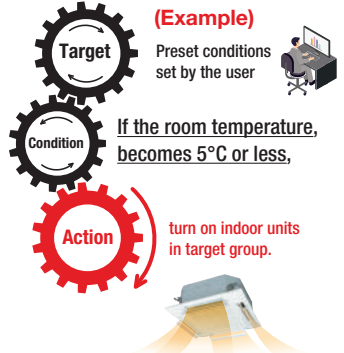

# Demand Control Function

The demand control function is a feature that controls the operation of air-conditioning units based on external input signals from a demand controller connected to the gateway. By connecting the gateway to the demand controller, the electricity demand of the indoor and outdoor units\* can be managed.

\* The function currently is only available for the KXZ3 series

# Various Scheduling Function

The M-access has various schedule function making central management of air-conditioners easier. The yearly calendar function provides wide flexibility to set up different operational schedules for weekday, holiday, and other specific occasions. Yearly calendar will be automatically updated according to your standard calendar settings.

Demand control



Demand control dialog (Indoor unit)



Yearly calendar

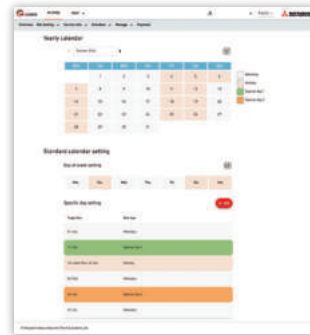

Schedule template



# Error Notifications

1. When detecting malfunction an alert is sent to the user by E-mail.
2. Could register multiple users as the sending address.
3. Could auto send the E-mail to the maintenance company.
4. For systems equipped with R32 safety devices, when a refrigerant leak is detected, an error notification is sent, and an alert is displayed on the screen to inform the user.

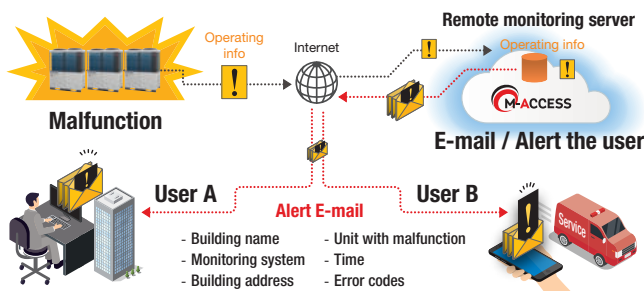

# History & Export Data Worth 10 years

From the Operation data history Screen 10 years worth of operation data history for all unit on the site could be downloaded. Other information including the error / caution code and service history for all unit on the site could be referred.

Error history



Operation data history



# Building Management Systems

**Our company offers** a wide range of control options for the KXZ system to suit any application, large or small, as well as connection to a new or existing BMS.



## SC-WBGW256 (Web & BACnet gateway)

SC-WBGW256 controls and monitors of up to 256 cells (some cells can have two or more indoor units and total number of indoor units can be up to 256 units) centralised to a network PC using the Superlink- II web gateway. Simple installation is assured with no special software requirements, operation is via Internet Explorer. A low power embedded CPU and compact flash ROM ensure a large storage capacity with high reliability (no moving parts such as a PC fan, etc). An IP address filter function combined with three-level user authentication check also ensures security. Also, SC-WBGW256 can be used as interface devices that convert Mitsubishi Heavy Industries Superlink- II communication data to BACnet code and are controlled centrally from a building management system.

Production by order



### [ In case of web gateway ]

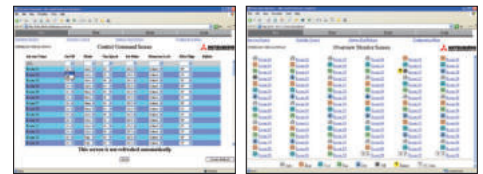
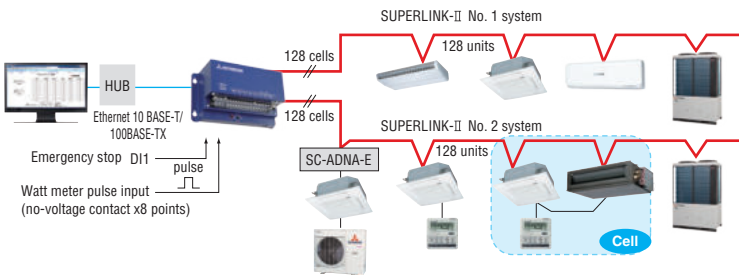

PC requirements: Windows7, Windows8.1, Windows10, Windows11.  
Monitor resolution 1366 x 768 or higher.

### [ In case of BACnet gateway ]

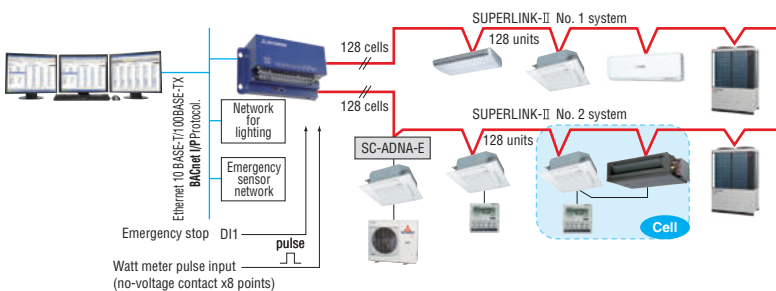

Users can manage up to 1024 units by connecting the four devices!!

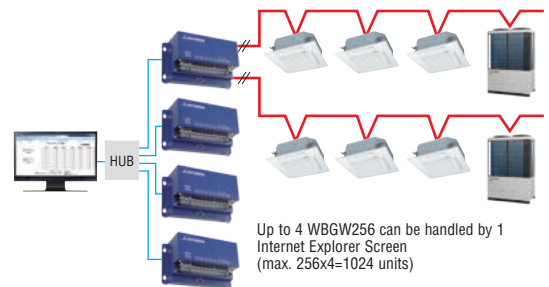

Up to 4 WBGW256 can be handled by 1 Internet Explorer Screen (max. 256x4=1024 units)

# INTESIS BMS Interface for Mitsubishi Heavy Industries Thermal Systems Air-Conditioners

All technical support, including specifying work, compatibility issues, product quality (repair and replacement issues), product liability issues and the required after sales service (including spare parts supply) will be provided by Intesis as it is an Intesis product.

Product sales and delivery will be conducted by Intesis as well.

For details concerning such matters please directly contact Intesis.

## Integration of Mitsubishi Heavy Industries Thermal Systems VRF in your KNX installation by Superlink

### Direct Connection to VRF outdoor units

The gateway is directly connected to the outdoor unit's communication bus and enables the control of all the indoor units connected to the system. This allows not only the control and monitoring of the main AC functions but the access to some internal variables of the outdoor units.

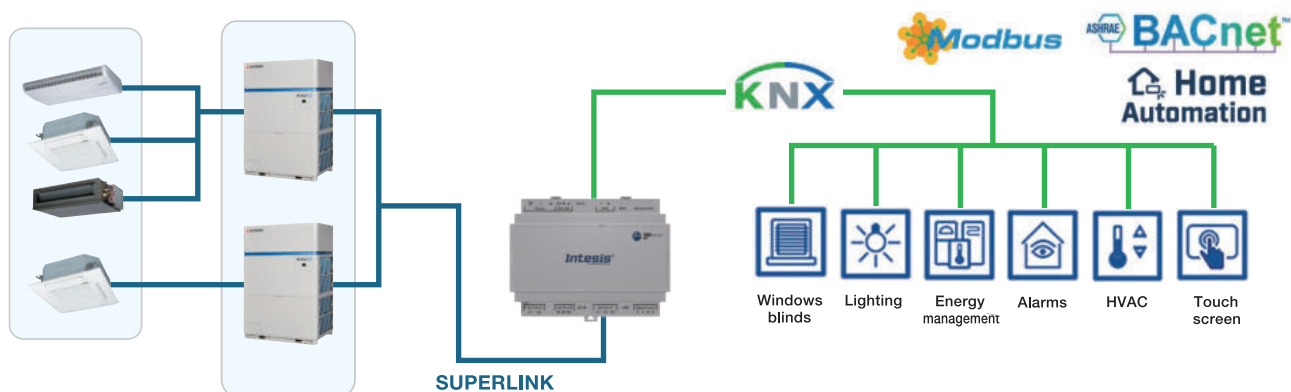

- Scan: Automatic identification of the units presents on the VRF system.
- Energy consumption signals from each indoor unit are available.
- Outdoor unit's signals available for the integration.
- Supports both BACnet/IP and BACnet MS/TP physical layers.
- Configuration through IP or USB (Console) port.
- Easy integration with Intesis MAPS.
- Automatic updates for both Intesis MAPS and interface's firmware.

## AC Cloud Control



PAC Model: INWMPMH1001R000

Please access the followings for details.

**Intesis**<sup>™</sup>  
BY HMS NETWORKS

URL | <http://www.intesis.com>  
email | [info@intesis.com](mailto:info@intesis.com)

# Support tools

## BIM (Building Information Modelling)

We can provide high quality Building Information Modelling (BIM) models in three formats:

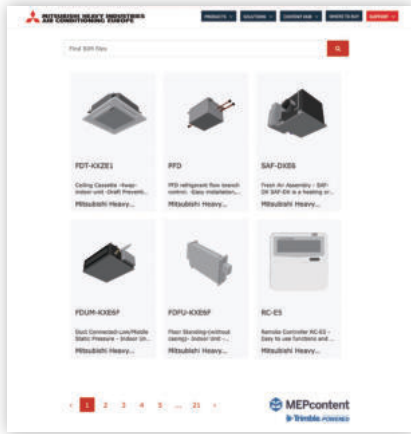

1. Revit
2. 3D Cad
3. IFC

(IFC provides an interoperability solution between different software applications. The format establishes international standards to import and export building objects and their properties)

### How and why BIM is used

BIM enables all disciplines of a project (Architects, engineers, quantity surveyors, contractors, clients etc..) to share a common model and data representing the project they are building.

- Better design visualization
- BIM reduces conflicts and changes during construction
- Increases overall accuracy of project documentation
- Improves cost estimating
- Improves energy analysis
- Simplifies reporting and scheduling



## e-seasonal

e-seasonal is an application for our Air-cooled VRF Outdoor unit selection.

By selecting a combination of systems, location and occupancy profiles you can simulate:

1. Annual seasonal efficiency calculation
2. Annual energy consumption, cost and CO2 emission estimation
3. Comparison with multiple solutions including conventional heaters

It is possible to download to your PC for an offline version or using a web browser for an online version. e-seasonal provides solution suggestions according to your requested design conditions.



# e-solution

Use our **e-solution design software tool** to find the latest specifications for our KXZ VRF systems. This software helps to simplify the processes to enable engineers to select the most suitable indoor units, outdoor units, pipework, controls & calculate any additional required refrigerants.

If you're an engineer interested in using e-solution, please register and download the e-solution via <https://mhiae.com/e-solution/> and be sure to download the latest updates when available.



Please be aware that this tool was developed to cater for the design of two and three pipe systems, and specifies the appropriate models and sizes. It also generates wiring diagrams and engineering drawing to export to AutoCAD or PDF. This flexibility allows engineers to print selected design information and technical data to present to potential clients. As well as personalising the design information into their own formats and documents for future proposals.

## MHI e-service App

**MHI e-service application** is available & free to download to both IOS and Android devices.

The application covers "Mitsubishi Heavy Industries Thermal Systems, Ltd" Air-conditioning systems: Split (RAC & PAC), VRF, Q-ton & AtoW.

This "MHI e-service" Application enables field engineers to make:  
A quick search of the meaning of error codes that may appear when there is a malfunction in a "Mitsubishi Heavy Industries Thermal Systems, Ltd" Air-conditioning system, and the probable cause for the malfunction.  
Scan the unit's QR code and search the meaning of error codes depending on the model type  
Additional refrigerant charge calculation for Split (PAC, RAC) & VRF  
Currently available in English & Spanish languages and Italian

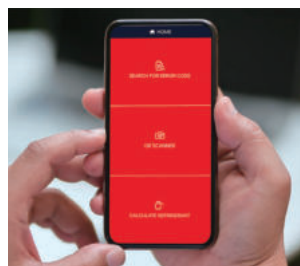

To download the App go to:



Android™



iPhone

"Android" and "Google Play" are trademarks or registered trademarks of Google LLC.  
"iPhone" is a trademark of Apple Inc. registered in the U.S. and other countries.



FDC400KXZE3, FDC450KXZE3, FDC500KXZE3

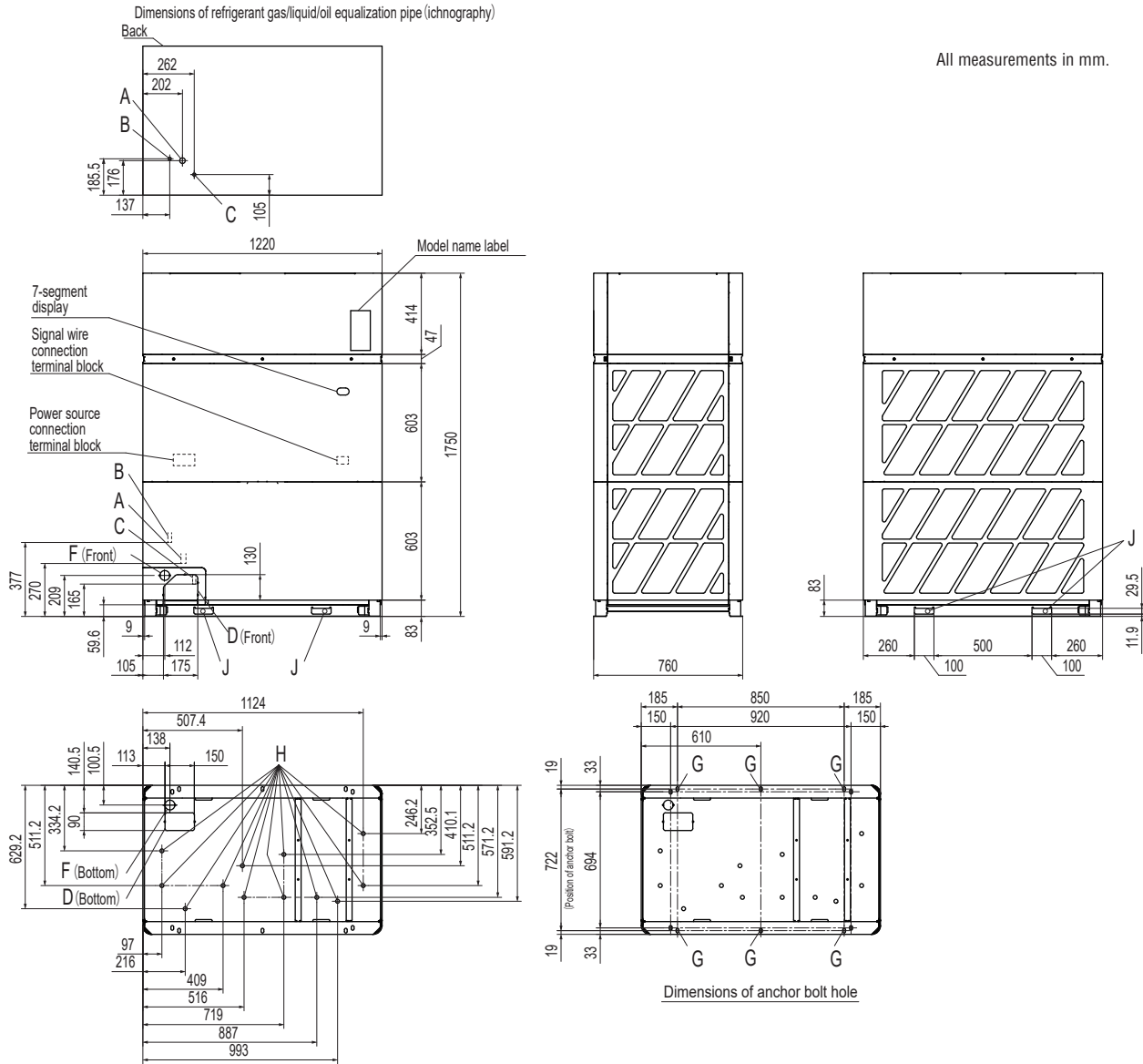

Mark	Content	
A	Refrigerant gas pipe	ø28.58(Brazing)
B	Refrigerant liquid pipe	ø12.7(Flare)
C	Refrigerant oil equalization pipe	ø12.7(Flare)
D	Knockout hole for pipes	175 × 130 (Front), 150 × 90 (Bottom)
F	Knockout hole for power wiring	ø50
G	Anchor bolt hole	M10 × 6 places
H	Drain hole	ø20 × 12 places
J	Hole for hanging	100 × 29.5

Dimensions	Installation limitations		
	1	2	3
L <sub>1</sub>	500	500	Open
L <sub>2</sub>	10(50)	50	10
L <sub>3</sub>	300	100(300)	300
L <sub>4</sub>	10(50)	50	Open
H <sub>1</sub>	1500	1500	Open
H <sub>2</sub>	No limit	No limit	No limit
H <sub>3</sub>	500	500	No limit
H <sub>4</sub>	No limit	No limit	Open

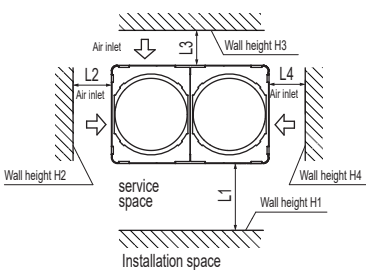

1. This installation example assumes operation at an ambient temperature under 43°C.
2. For use at higher ambient temperatures, install according to the dimension in parentheses.
3. If H<sub>1</sub> or H<sub>3</sub> exceeds the wall height limit in the table, H<sub>1</sub>/2 and H<sub>3</sub>/2 should be added to the L<sub>1</sub> and L<sub>3</sub> respectively.

FDC530KXZE3, FDC560KXZE3, FDC615KXZE3, FDC670KXZE3

All measurements in mm.

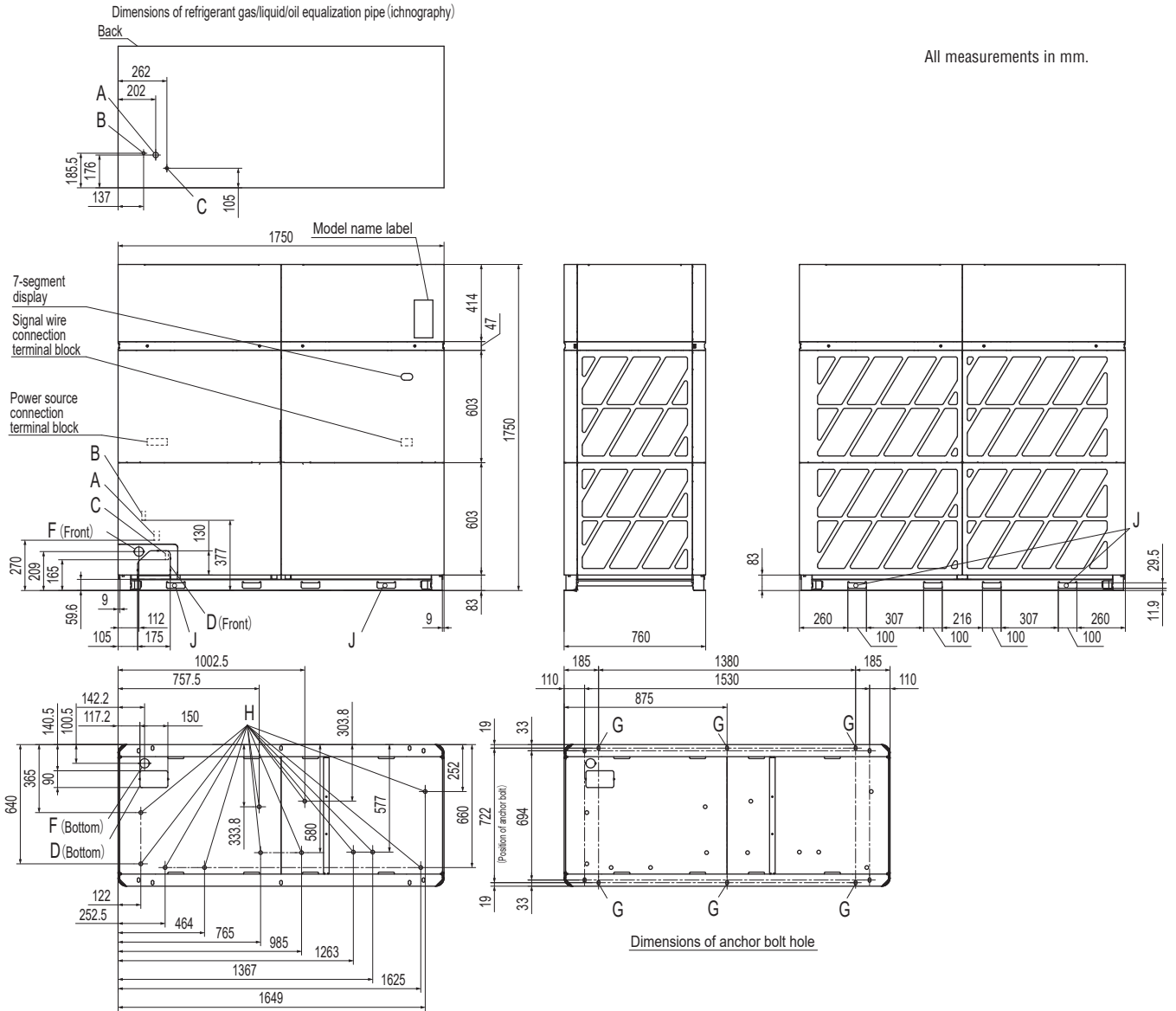

Mark	Content	
A	Refrigerant gas pipe	ø28.58(Brazing)
B	Refrigerant liquid pipe	ø12.7(Flare)
C	Refrigerant oil equalization pipe	ø12.7(Flare)
D	Knockout hole for pipes	175 × 130 (Front), 150 × 90 (Bottom)
F	Knockout hole for power wiring	ø50
G	Anchor bolt hole	M10 × 6 places
H	Drain hole	ø20 × 12 places
J	Hole for hanging	100 × 29.5

Dimensions	Installation limitations		
	1	2	3
L1	500	500	Open
L2	10(50)	50	10
L3	300	100(300)	300
L4	10(50)	50	Open
H1	1500	1500	Open
H2	No limit	No limit	No limit
H3	500	500	No limit
H4	No limit	No limit	Open

1. This installation example assumes operation at an ambient temperature under 43°C.
2. For use at higher ambient temperatures, install according to the dimension in parentheses.
3. If H1 or H3 exceeds the wall height limit in the table, H1/2 and H3/2 should be added to the L1 and L3 respectively.

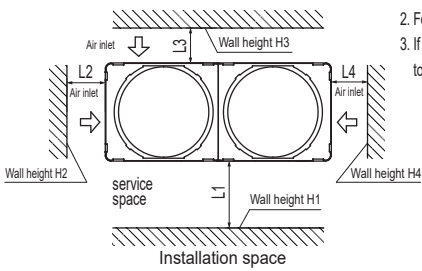

FDC280KXZE2, FDC335KXZE2

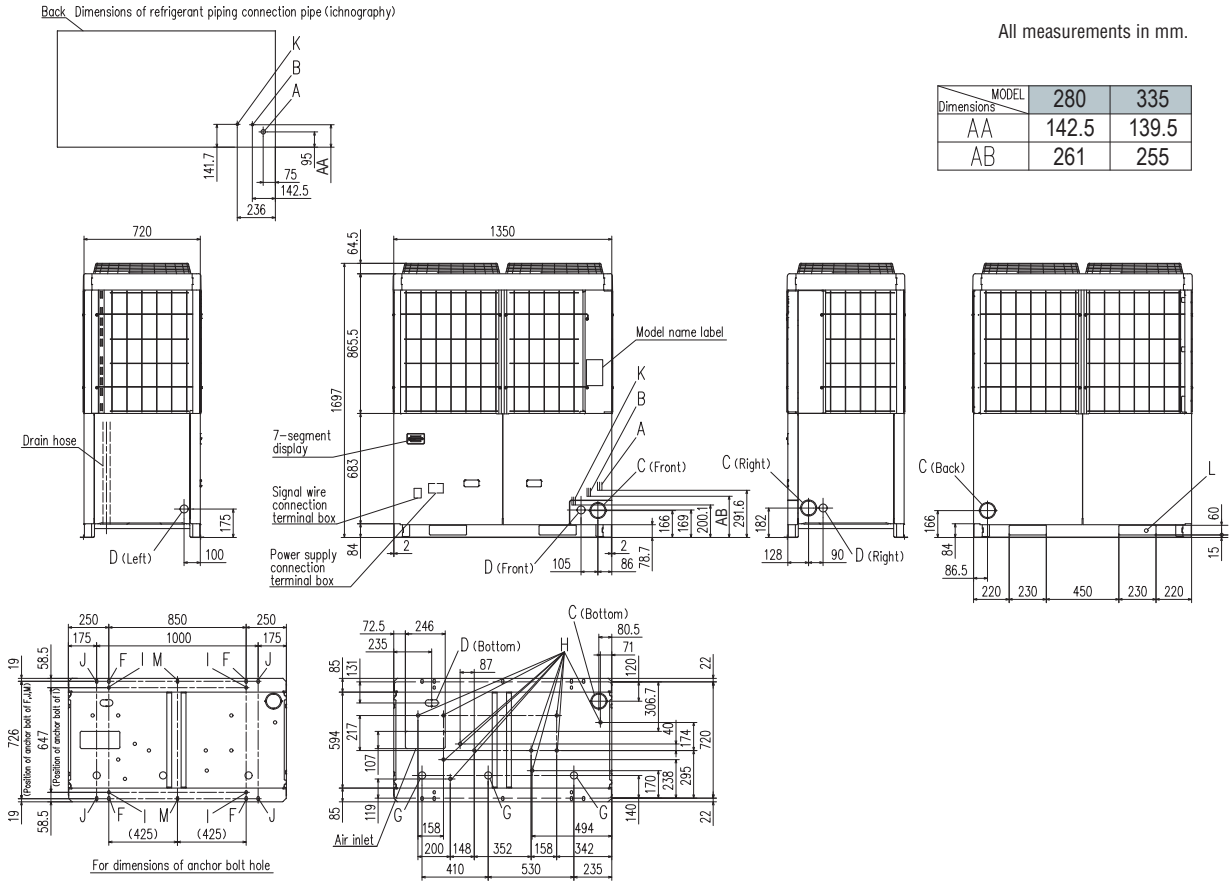

Mark	Content	280	335
A	Refrigerant gas piping connection pipe	ø22.22(Brazing)	ø25.4(Brazing)
B	Refrigerant liquid piping connection pipe	ø9.52(Flare)	ø12.7(Flare)
C	Refrigerant piping exit hole	ø88(or ø100)	
D	Power supply entry hole	ø50 (right · left · front), long hole 40 x 80 (bottom)	
F	Anchor bolt hole	M10 x 4 places	
G	Drain waste water hose hole	ø45 x 3 places	
H	Drain hole	ø20 x 11 places	
K	Refrigerant oil equalization piping connection pipe	ø9.52(Flare)	
L	Carrying in or hole for hanging	230 x 60	

Installation example		
Dimensions	1	2
L <sub>1</sub>	500	Open
L <sub>2</sub>	10(30)	10(30)
L <sub>3</sub>	100	100
L <sub>4</sub>	10(30)	Open
H <sub>1</sub>	1500	Open
H <sub>2</sub>	No limit	No limit
H <sub>3</sub>	1000	No limit
H <sub>4</sub>	No limit	Open

( ) :In case it is the promised installation location that the outdoor unit is used on conditions with the ambient temperature of 43°C or more.

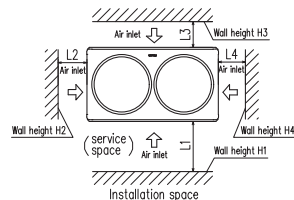

When more than one unit is installed

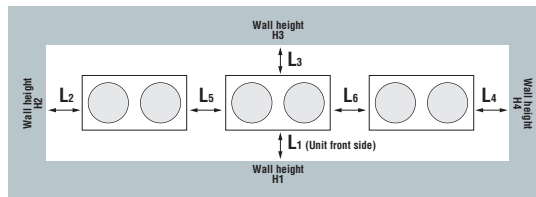

Installation example		
Dimensions	1	2
L <sub>1</sub>	500	Open
L <sub>2</sub>	10(30)	200
L <sub>3</sub>	100	300
L <sub>4</sub>	10(30)	Open
L <sub>5</sub>	10(30)	400
L <sub>6</sub>	10(30)	400
H <sub>1</sub>	1500	Open
H <sub>2</sub>	No limit	No limit
H <sub>3</sub>	1000	No limit
H <sub>4</sub>	No limit	Open

FDC400KXZE2, FDC450KXZE2, FDC475KXZE2, FDC500KXZE2, FDC560KXZE2

Back Dimensions of refrigerant piping connection pipe (ichnography)

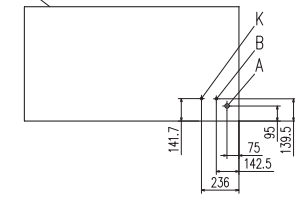

All measurements in mm.

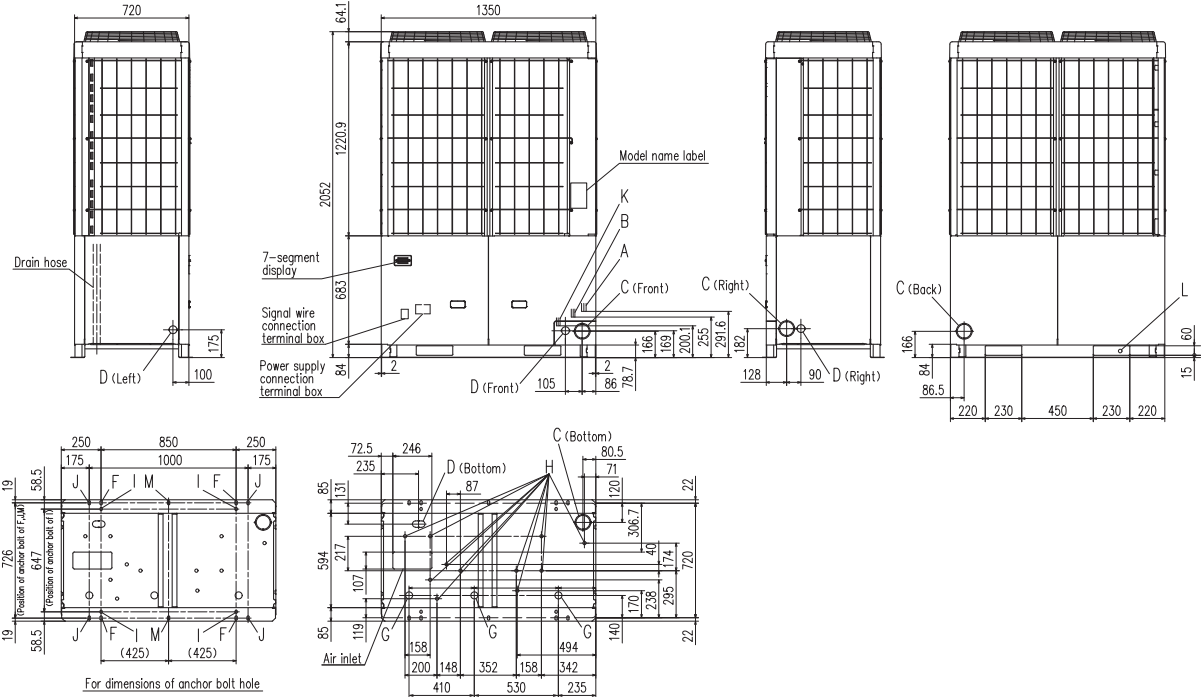

For dimensions of anchor bolt hole

Mark	Content	400	450, 475, 500, 560
A	Refrigerant gas piping connection pipe	ø25.4(Brazing)	ø28.58(Brazing)
B	Refrigerant liquid piping connection pipe		ø12.7(Flare)
C	Refrigerant piping exit hole		ø88(or ø100)
D	Power supply entry hole	ø50 (right · left · front), long hole 40 x 80 (bottom)	
F	Anchor bolt hole	M10 x 4 places	
G	Drain waste water hose hole	ø45 x 3 places	
H	Drain hole	ø20 x 11 places	
K	Refrigerant oil equalization piping connection pipe	ø9.52(Flare)	
L	Carrying in or hole for hanging	230 x 60	

Installation example		
Dimensions	1	2
L <sub>1</sub>	500	Open
L <sub>2</sub>	10(30)	10(30)
L <sub>3</sub>	100	100
L <sub>4</sub>	10(30)	Open
H <sub>1</sub>	1500	Open
H <sub>2</sub>	No limit	No limit
H <sub>3</sub>	1000	No limit
H <sub>4</sub>	No limit	Open

( ) :In case it is the promised installation location that the outdoor unit is used on conditions with the ambient temperature of 43°C or more.

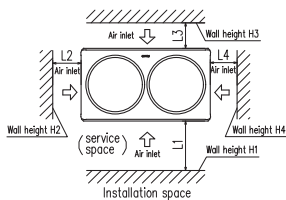

When more than one unit is installed

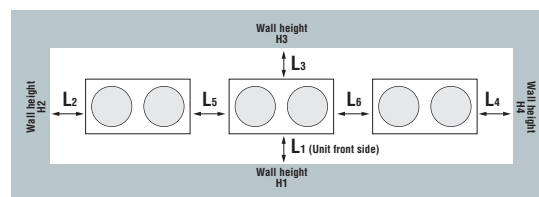

Installation example		
Dimensions	1	2
L <sub>1</sub>	500	Open
L <sub>2</sub>	10(30)	200
L <sub>3</sub>	100	300
L <sub>4</sub>	10(30)	Open
L <sub>5</sub>	10(30)	400
L <sub>6</sub>	10(30)	400
H <sub>1</sub>	1500	Open
H <sub>2</sub>	No limit	No limit
H <sub>3</sub>	1000	No limit
H <sub>4</sub>	No limit	Open

# KXZ<sup>2</sup> Heat recovery 3-pipe systems

FDC224KXZRE2, FDC280KXZRE2, FDC335KXZRE2

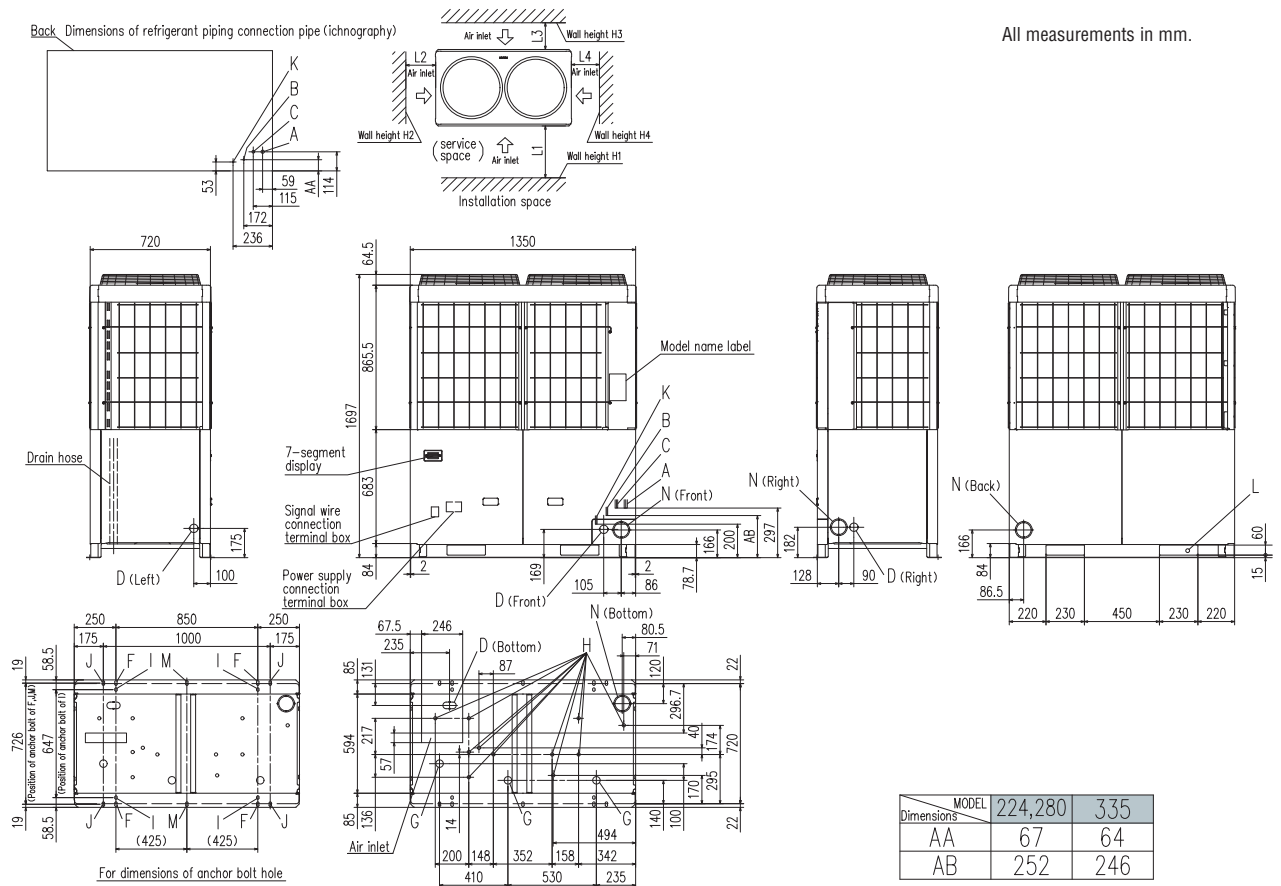

All measurements in mm.

Mark	Content	224	280	335
A	Refrigerant suction gas piping connection entrance	ø19.05(Brazing)	ø22.22(Brazing)	ø25.4(Brazing)
B	Refrigerant liquid piping connection entrance	ø9.52(Flare)		ø12.7(Flare)
C	Refrigerant discharge gas piping connection entrance	ø15.88(Brazing)	ø19.05(Brazing)	
D	Power supply entry hole	ø50(right · left · front),long hole 40x80(Bottom)		
F	Anchor bolt hole	M10 x 4 places		
G	Drain waste water hose hole	ø45 x 3 places		
H	Drain hole	ø20 x 11 places		
K	Refrigerant oil equalization piping connection entrance	ø9.52(Flare)		
L	Carrying in or hole for hanging	230x60		
N	Refrigerant piping exit hole	ø88(or ø100)		

Installation example		
Dimensions	1	2
L <sub>1</sub>	500	Open
L <sub>2</sub>	10(30)	10(30)
L <sub>3</sub>	100	100
L <sub>4</sub>	10(30)	Open
H <sub>1</sub>	1500	Open
H <sub>2</sub>	No limit	No limit
H <sub>3</sub>	1000	No limit
H <sub>4</sub>	No limit	Open

() :In case it is the promised installation location that the outdoor unit is used on conditions with the ambient temperature of 43°C or more.





# Micro KXZ Heat pump systems

FDC121KXZEN1, FDC140KXZEN1, FDC155KXZEN1  
 FDC121KXZES1, FDC140KXZES1, FDC155KXZES1

All measurements in mm.

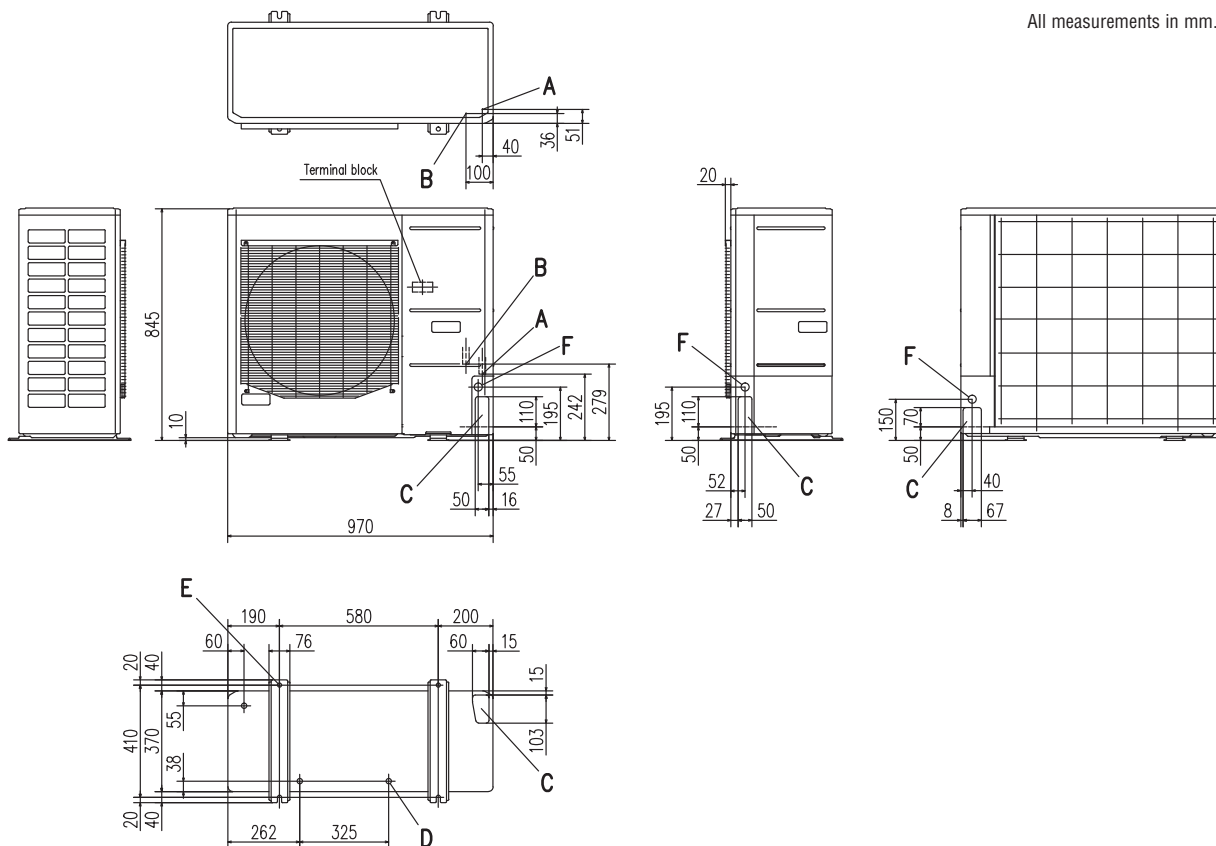

Mark	Content	
A	Service valve connection (gas side)	ø15.88 (5/8") (Flare)
B	Service valve connection (liquid side)	ø9.52 (3/8") (Flare)
C	Pipe/cable draw-out hole	
D	Drain discharge hole	ø20 x 3 places
E	Anchor bolt hole	M10 x 4 places
F	Cable draw-out hole	ø30 x 3 places

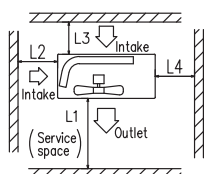

	I	II	III
L1	Open	Open	500
L2	300	5	Open
L3	150	300	150
L4	5	5	5

Minimum installation space

Notes:

- (1) It must not be surrounded by walls on the four sides.
- (2) The unit must be fixed with anchor bolts. An anchor bolt must not protrude more than 15mm.
- (3) Where the unit is subject to strong winds, lay it in such a direction that the blower outlet faces perpendicularly to the dominant wind direction.
- (4) Leave 1m or more space above the unit.
- (5) A wall in front of the blower outlet must not exceed the units height.
- (6) The model name label is attached on the lower right corner of the front panel.

# Micro KXZ Heat pump systems

FDC224KXZME1, FDC280KXZME1, FDC335KXZME1A

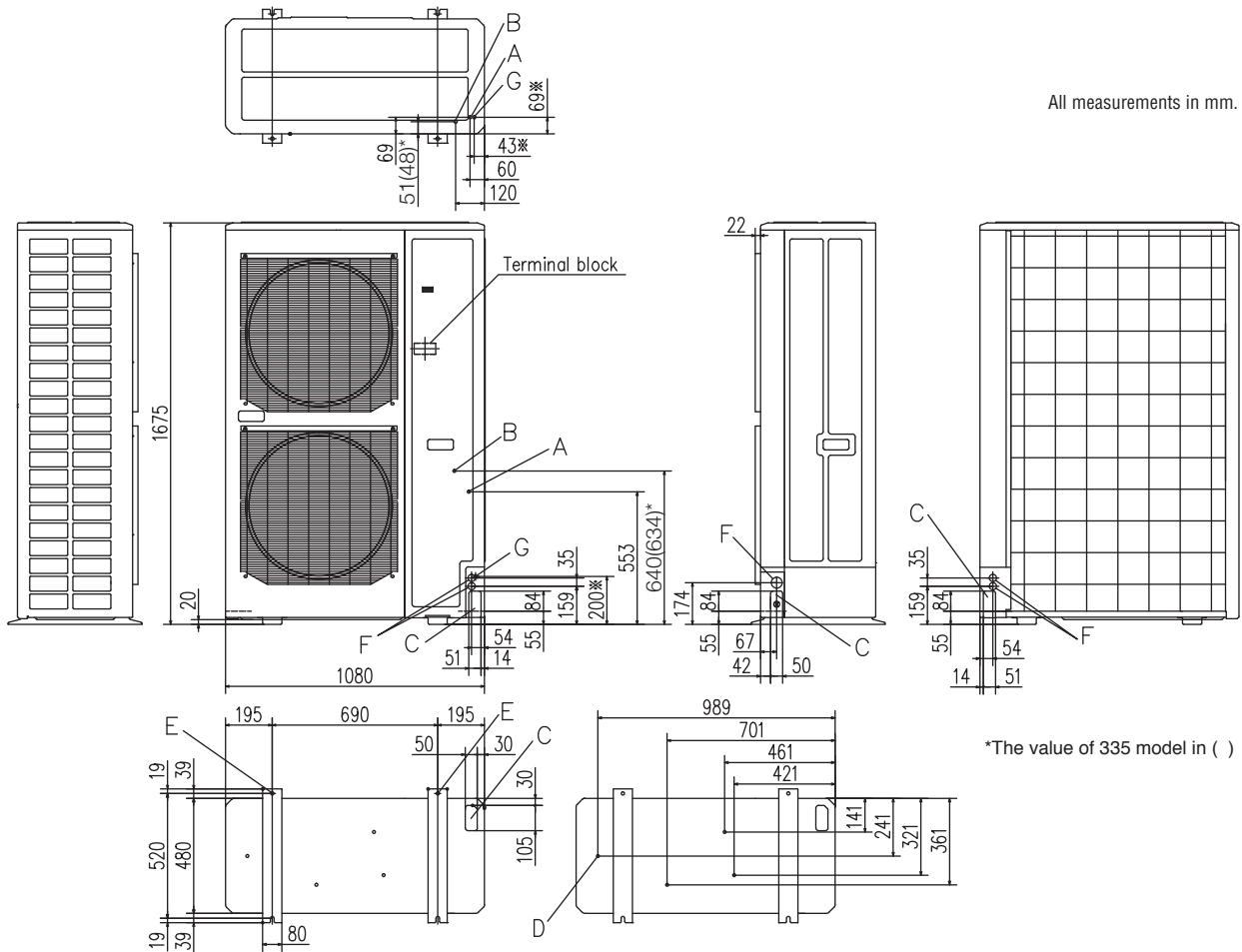

Mark	Content	224	280	335
A	Service valve connection of the attached connecting pipe (gas side)	ø19.05 (3/4") (Flare)	ø19.05 (3/4") (Flare)	ø19.05 (3/4") (Flare)
B	Service valve connection (liquid side)	ø9.52 (3/8") (Flare)	ø9.52 (3/8") (Flare)	ø12.7 (1/2") (Flare)
C	Pipe/cable draw-out hole	4places	4places	4places
D	Drain discharge hole	ø20 x 4places	ø20 x 4places	ø20 x 4places
E	Anchor bolt hole	M10 x 4places	M10 x 4places	M10 x 4places
F	Cable draw-out hole	ø30 x 2places (front) ø45 (side) ø30 x 2places (back)	ø30 x 2places (front) ø45 (side) ø30 x 2places (back)	ø30 x 2places (front) ø45 (side) ø30 x 2places (back)
G	Connecting position of the local pipe. (gas side)	ø19.05 (3/4")(Brazing)	ø22.22 (7/8")(Brazing)	ø25.4 (1")(Brazing)

Notes:

- (1) It must not be surrounded by walls on the four sides.
- (2) The unit must be fixed with anchor bolts. An anchor bolt must not protrude more than 15mm.
- (3) Where the unit is subject to strong winds, the blower outlet should face perpendicularly to the dominant wind direction.
- (4) Leave a 1m or more space above the unit.
- (5) A wall in front of the blower outlet must not exceed the units height.
- (6) The model name label is attached on the lower right corner of the front.
- (7) Connect the Service valve with local pipe by using the pipe of the attachment.(Gas side only)
- (8) Mark ※ shows the connecting position of the local pipe.(Gas side only)

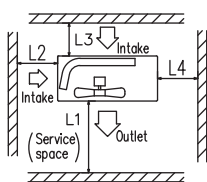

Minimum installation space

	I	II	III
L1	Open	Open	1500(500) <sup>*1</sup>
L2	300	5	Open
L3	300	300	300
L4	250(5) <sup>*2</sup>	250(5) <sup>*2</sup>	250(5) <sup>*2</sup>

Notes:

- \*1 Figure in ( ) shows the value applicable when the flex flow adaptor is installed.
- \*2 Under the setting condition as specified in ( ), it is necessary to secure 250 mm for the dimension L4 when replacing the compressor. Establish this for example by moving the unit during the work.

# KXZ Lite Heat pump systems

FDC224KXZPE1, FDC280KXZPE1

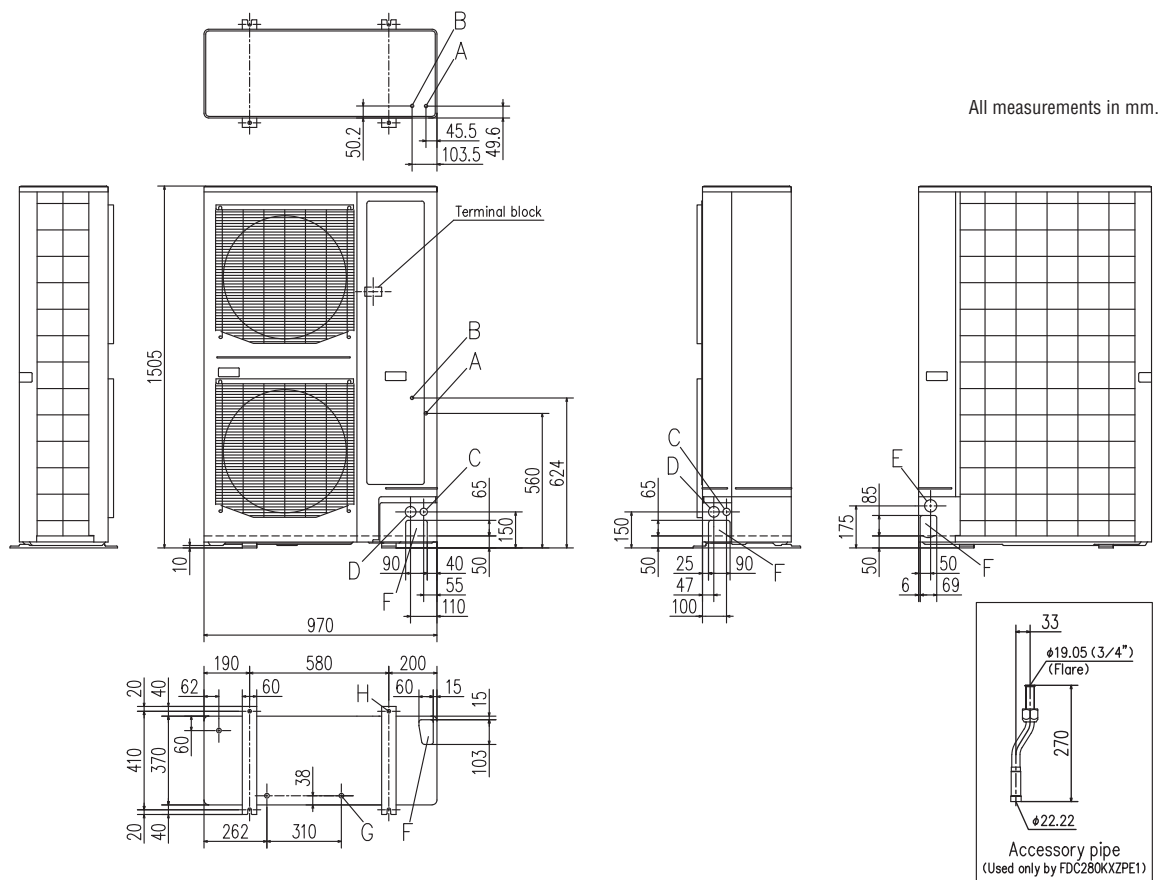

Mark	Content	
<b>A</b>	Service valve connection of the attached connecting pipe (gas side)	ø19.05 (3/4") (Flare)
<b>B</b>	Service valve connection (liquid side)	ø9.52 (3/8") (Flare)
<b>C</b>	Cable draw-out hole (front · side)	ø30 x 2places
<b>D</b>	Cable draw-out hole (front · side)	ø45 x 2places
<b>E</b>	Cable draw-out hole (back)	ø50
<b>F</b>	Pipe/cable draw-out hole	4places
<b>G</b>	Drain discharge hole	ø20 x 3places
<b>H</b>	Anchor bolt hole	M10 x 4places

**Notes:**

- (1) It must not be surrounded by walls on the four sides.
- (2) The unit must be fixed with anchor bolts.  
An anchor bolt must not protrude more than 15mm.
- (3) Where the unit is subject to strong winds, lay it in such a direction that the blower outlet faces perpendicularly to the dominant wind direction.
- (4) Leave 1m or more space above the unit.
- (5) A wall in front of the blower outlet must not exceed the units height.
- (6) The model name label is attached on the lower right corner of the front panel.
- (7) Connect the Service valve with local pipe by using the pipe of the attachment.  
(Gas side only) (Accessory pipe is used only by FDC280KXZPE1)
- (8) Regarding attaching the pipe of accessories, refer to an attached installation manual.

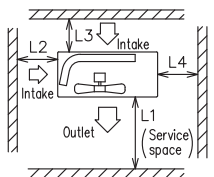

Minimum installation space

	I	II	III
<b>L1</b>	Open	Open	500
<b>L2</b>	300	5	Open
<b>L3</b>	150	300	150
<b>L4</b>	250 (5)*1	250 (5)*1	250 (5)*1

**Notes:**

- \*1 At the time of the installation at ( ) dimension, Secure space of 250mm in lateral (L4) by unit movement at the time of the exchange work of the compressor.

# KXZ Water cooled series

FDC224KXZE1, FDC280KXZE1, FDC335KXZE1

All measurements in mm.

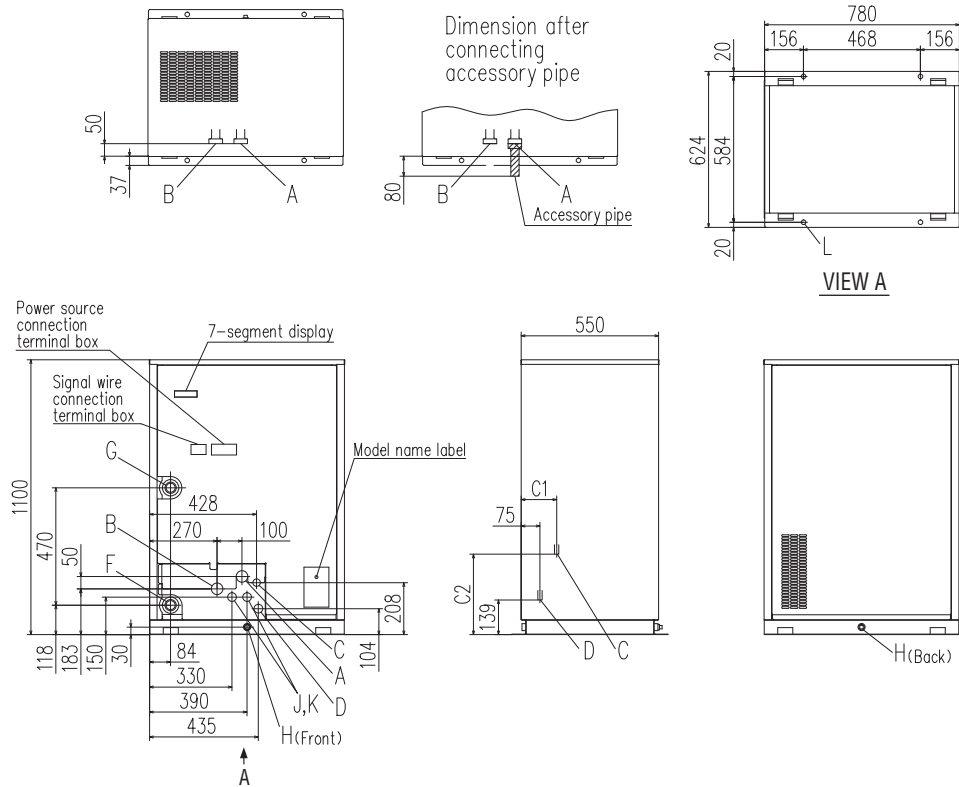

Mark	Content	
A	High/low gas line	Refer to piping size
B	-	Not to use.
C	Liquid line	Refer to piping size
D	Oil equalization line	Refer to piping size
F	Water inlet	R1 1/4
G	Water outlet	R1 1/4
H	Drain outlet	Rp 1/2,2places
J	Power source intake	ø35
K	Signal wiring intake	ø35
L	Anchor bolt hole	ø18,4places

Dimension	FDC-KXZE1	
	224,280	335
C1	142	139
C2	322	316

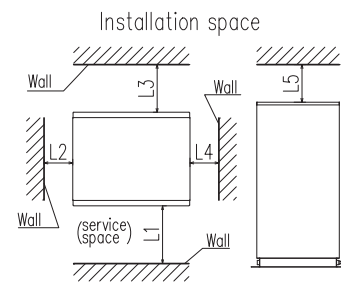

## Piping size

	FDC224KXZE1	FDC280KXZE1	FDC335KXZE1	Connection method
High/low gas line	ø19.05	ø22.22	ø25.4	Flange
Liquid line	ø9.52	ø9.52	ø12.7	Flare
Oil equalization line	ø9.52	ø9.52	ø9.52	

Dimension	Installation example	1
	L1	
L2		20 or more
L3		500 or more
L4		20 or more
L5		300 or more

# PFD refrigerant flow branch control less than 11.2kW / less than 18.0kW

PFD1124-E, PFD1804-E

All measurements in mm.

## PFD1124-E

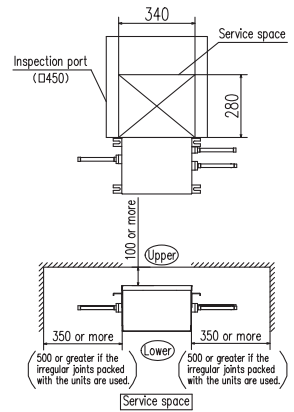
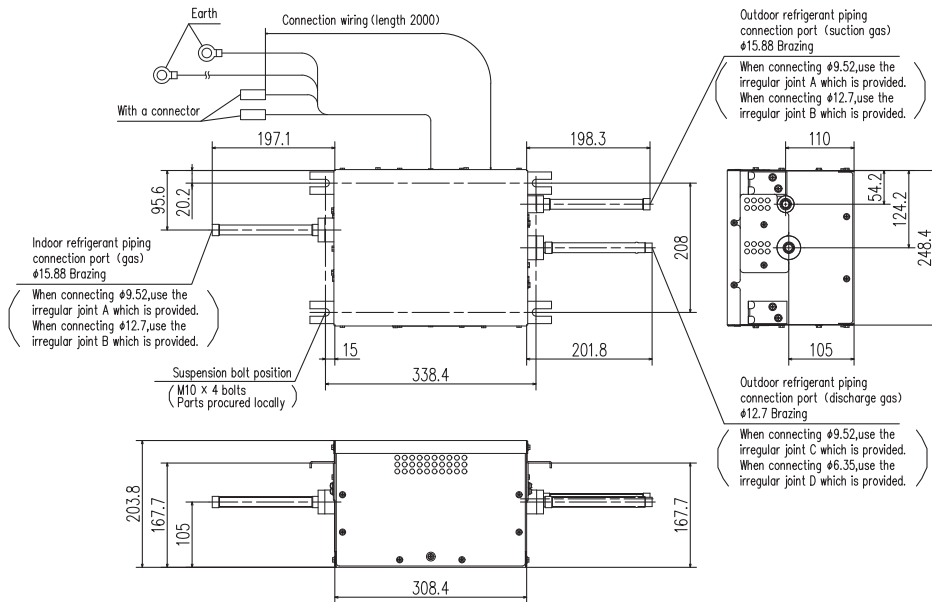

## PFD1804-E

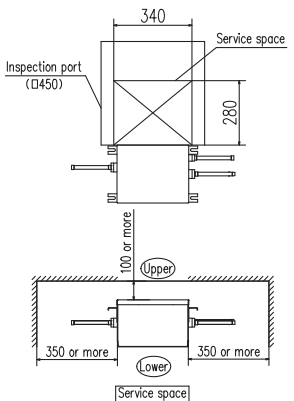
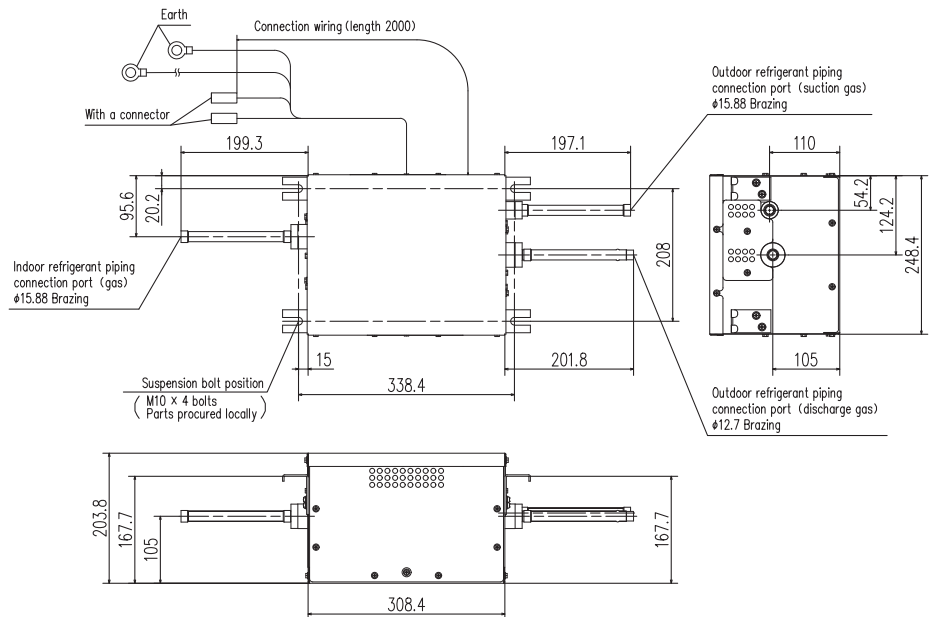

# PFD refrigerant flow branch control

## 28.0kW or less / less than 37.1kW (less than 11.2kW x 4 branches)

PFD2804-E, PFD1124x4-E

All measurements in mm.

### PFD2804-E

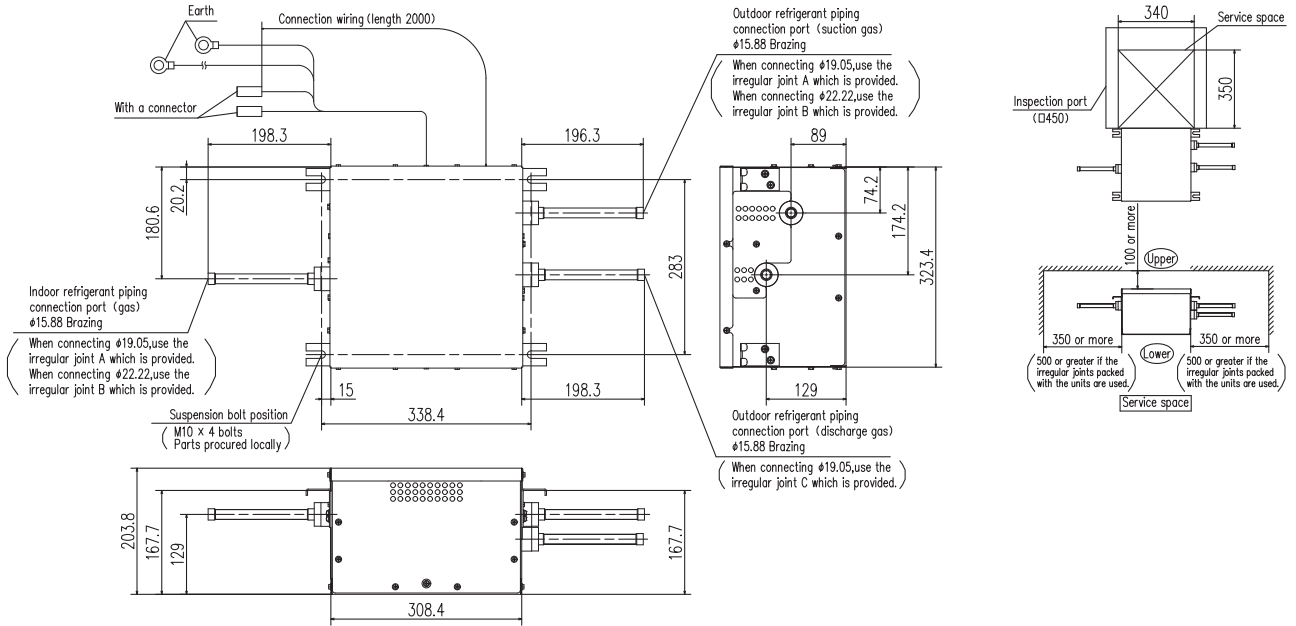

### PFD1124X4-E

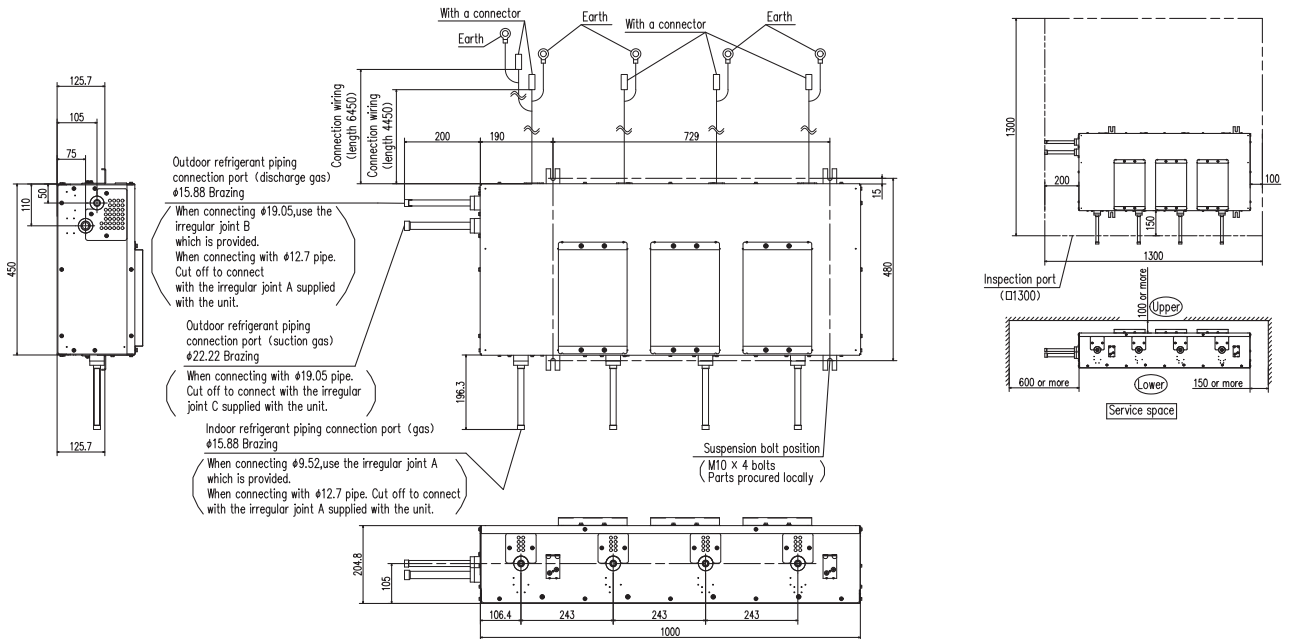

# Ceiling Cassette - 4way - FDT

FDT28KXZE3-W, FDT36KXZE3-W, FDT45KXZE3-W, FDT56KXZE3-W, FDT71KXZE3-W

All measurements in mm.

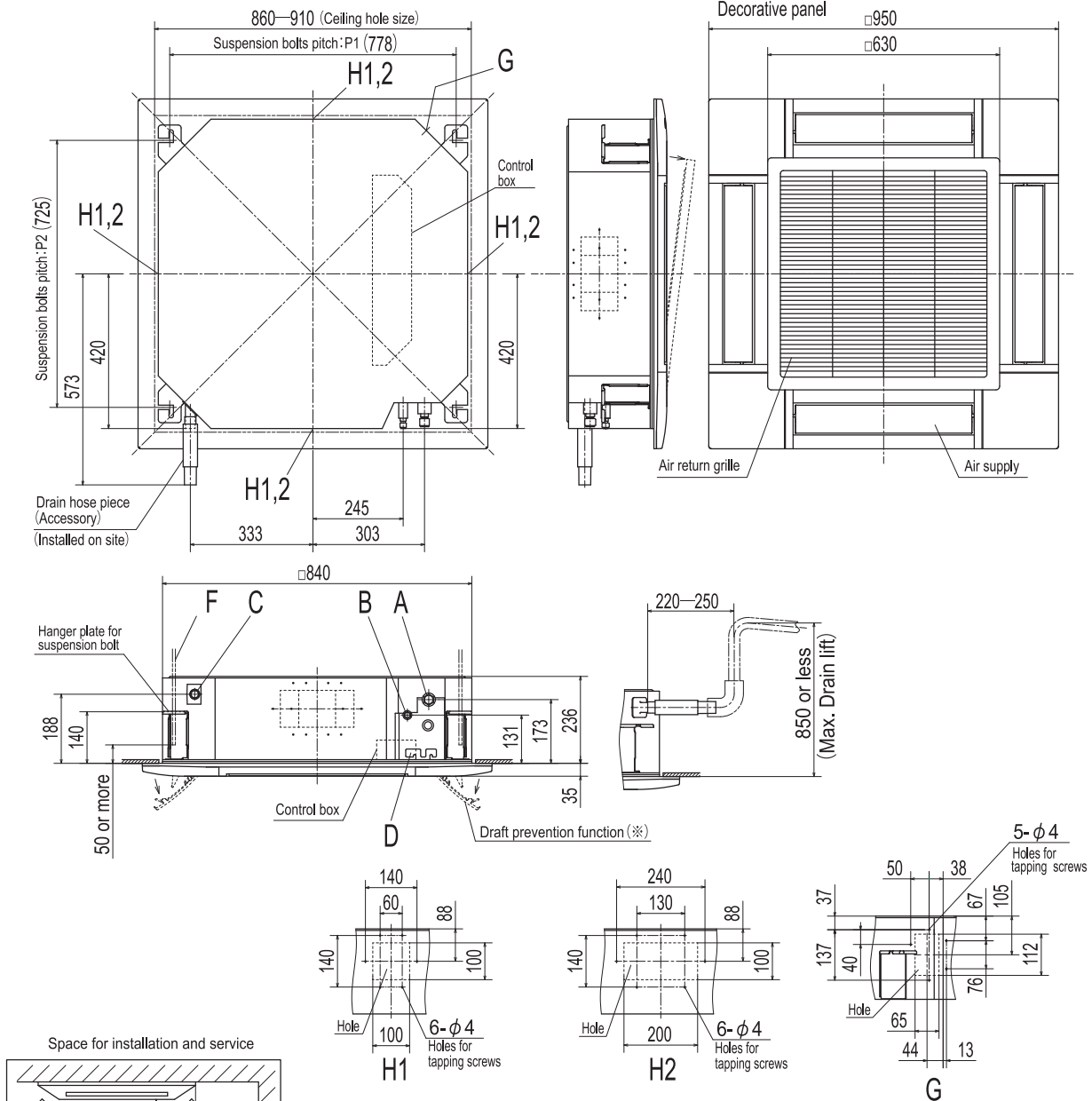

Make a space of 4000 or more between the units when installing more than one.

- Notes
- (1) The model name label is attached to the control box lid.
  - (2) Suspension bolt pitch P1,P2 is adjustable by a pattern of the right table.
  - (3) Draft prevention function (※) is provided on the panel T-PSAE-5CW-E, T-PSAE-5CB-E only.

Suspension bolt pitch range

Symbol Pattern	P1	P2
1	770	725-770
2	770-800	725

Symbol	Content			
	Model	28	36,45,56	71
A	Gas piping	φ9.52(3/8") (Flare)	φ12.7(1/2") (Flare)	φ15.88(5/8") (Flare)
B	Liquid piping	φ6.35(1/4") (Flare)	φ9.52(3/8") (Flare)	
C	Drain piping	VP25 (O.D.32)		
D	Hole for wiring			
F	Suspension bolts	M10 or M8		
G	Outside air opening for ducting	(Knock out)		
H1	Air outlet opening for ducting	φ 125 (Knock out)		
H2		φ 200 (Knock out)		

# Ceiling Cassette - 4way - FDT

FDT90KXE3-W, FDT112KXE3-W, FDT140KXE3-W, FDT160KXE3-W

All measurements in mm.

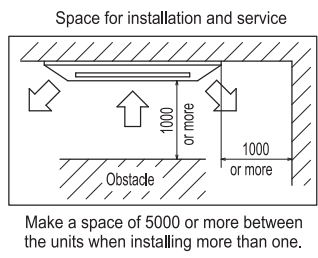
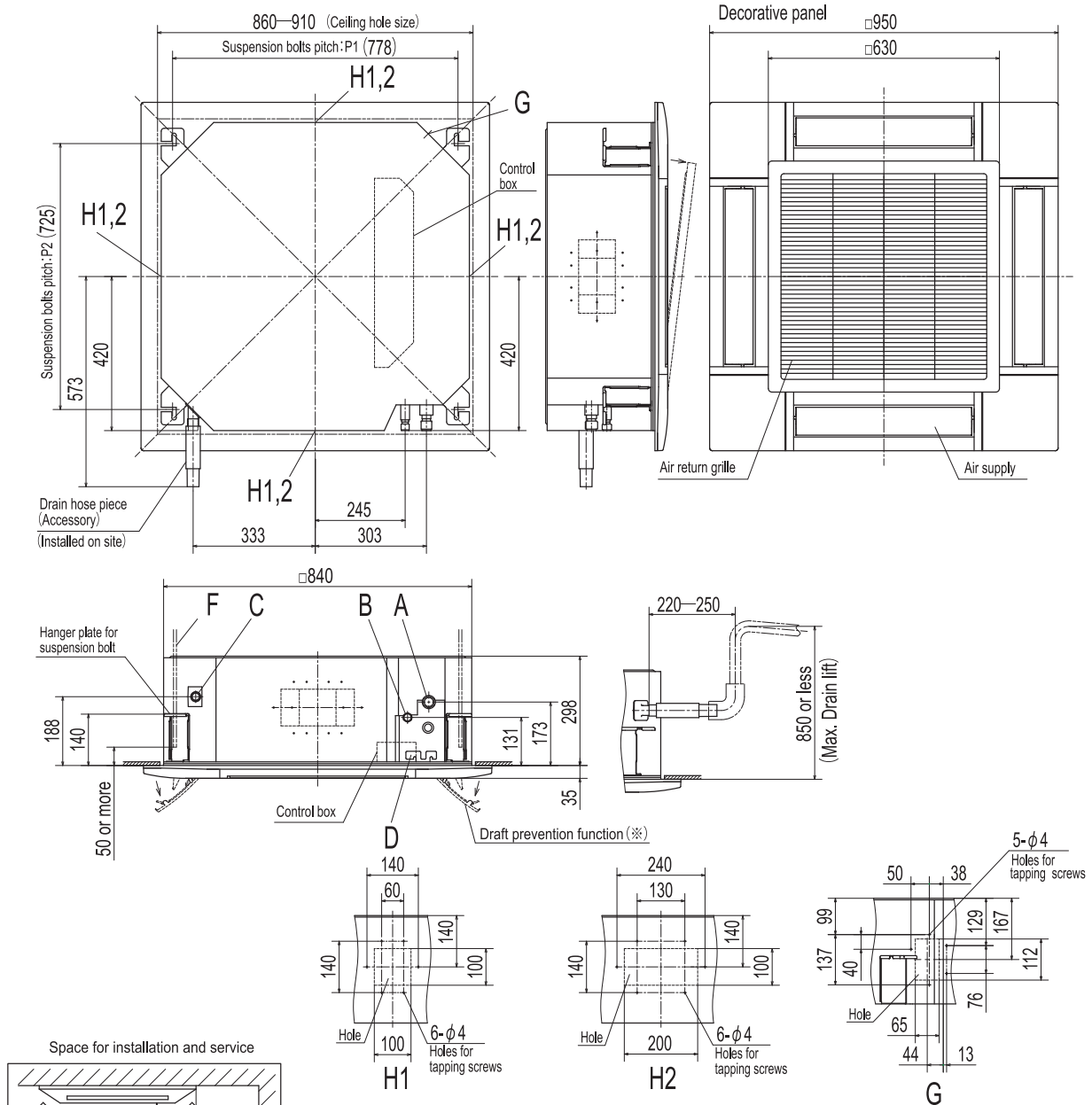

Make a space of 500 or more between the units when installing more than one.

- Notes (1) The model name label is attached to the control box lid.  
 (2) Suspension bolt pitch P1,P2 is adjustable by a pattern of the right table.  
 (3) Draft prevention function (※) is provided on the panel T-PSAE-5CW-E, T-PSAE-5CB-E only.

Suspension bolt pitch range

Symbol Pattern	P1	P2
1	770	725-770
2	770-800	725

Symbol	Content	
A	Gas piping	φ 15.88 (5/8") (Flare)
B	Liquid piping	φ 9.52 (3/8") (Flare)
C	Drain piping	VP25 (O.D.32)
D	Hole for wiring	
F	Suspension bolts	M10 or M8
G	Outside air opening for ducting	(Knock out)
H1	Air outlet opening for ducting	φ 125 (Knock out)
H2		φ 200 (Knock out)

# Ceiling Cassette - 4way - FDT

FDT28KXZE1, FDT36KXZE1, FDT45KXZE1, FDT56KXZE1, FDT71KXZE1

All measurements in mm.

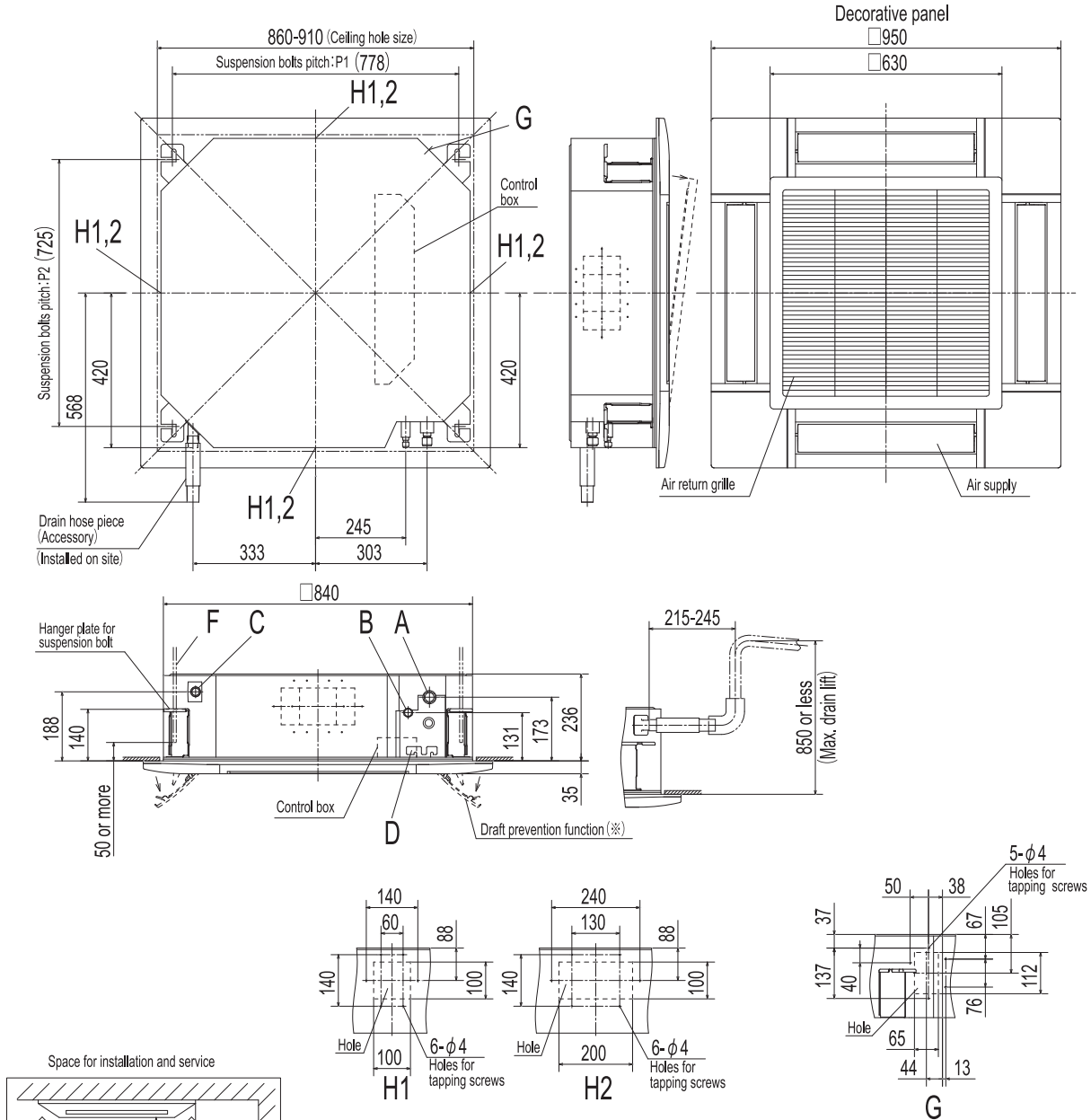

Make a space of 4000 or more between the units when installing more than one.

- Notes
- (1) The model name label is attached to the control box lid.
  - (2) Suspension bolt pitch P1, P2 is adjustable by a pattern of the right table.
  - (3) Draft prevention function (\*) is provided on the panel T-PSAE-5BW-E, T-PSAE-5BB-E only.

Suspension bolt pitch range

Symbol	P1	P2
1	770	725-770
2	770-800	725

Symbol	Content			
	Model	28	36,45,56	71
A	Gas piping	φ5.92(3/8") (Flare)	φ12.7(1/2") (Flare)	φ15.88(5/8") (Flare)
B	Liquid piping	φ6.35(1/4") (Flare)	φ9.52(3/8") (Flare)	φ9.52(3/8") (Flare)
C	Drain piping	VP25 (O.D.32)		
D	Hole for wiring			
F	Suspension bolts	(M10 or M8)		
G	Outside air opening for ducting	(Knock out)		
H1	Air outlet opening for ducting	φ 125 (Knock out)		
H2	Air outlet opening for ducting	φ 200 (Knock out)		

# Ceiling Cassette - 4way - FDT

FDT90KXZE1, FDT112KXZE1, FDT140KXZE1, FDT160KXZE1

All measurements in mm.

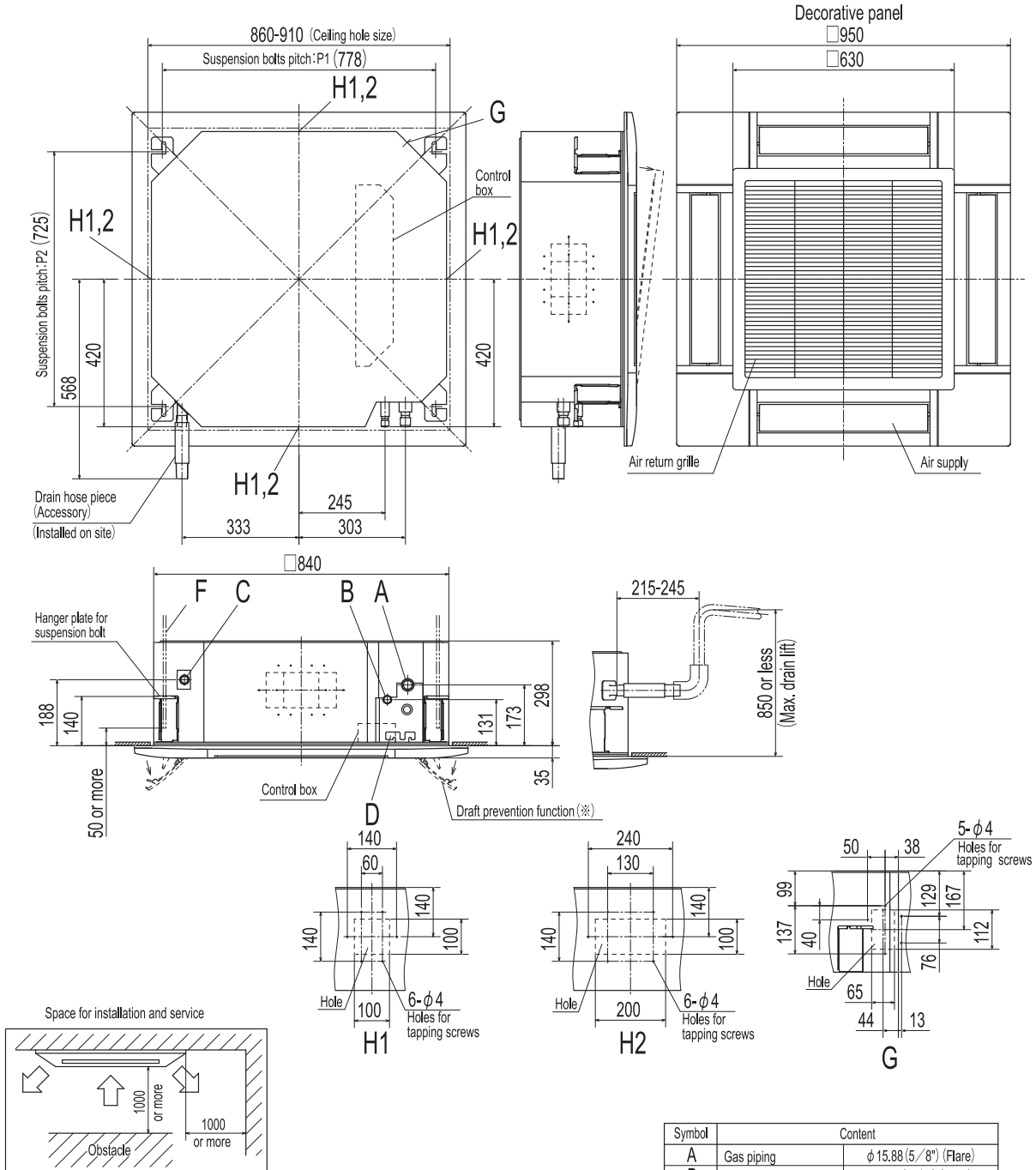

Make a space of 5000 or more between the units when installing more than one.

- Notes
- (1) The model name label is attached to the control box lid.
  - (2) Suspension bolt pitch P1, P2 is adjustable by a pattern of the right table.
  - (3) Draft prevention function (\*\*) is provided on the panel T-PSAE-5BW-E, T-PSAE-5BB-E only.

## Suspension bolt pitch range

Symbol Pattern	P1	P2
1	770	725-770
2	770-800	725

Symbol	Content	
A	Gas piping	φ 15.88 (5/8") (Flare)
B	Liquid piping	φ 9.52 (3/8") (Flare)
C	Drain piping	VP25 (O.D.32)
D	Hole for wiring	
F	Suspension bolts	(M10 or M8)
G	Outside air opening for ducting	(Knock out)
H1	Air outlet opening for ducting	φ 125 (Knock out)
H2	Air outlet opening for ducting	φ 200 (Knock out)

# Ceiling Cassette - 4way Compact FDTC

FDTC15KXZE3-W, FDTC22KXZE3-W, FDTC28KXZE3-W, FDTC36KXZE3-W, FDTC45KXZE3-W, FDTC56KXZE3-W  
FDTC15KXZE1, FDTC22KXZE1, FDTC28KXZE1, FDTC36KXZE1, FDTC45KXZE1, FDTC56KXZE1

All measurements in mm.

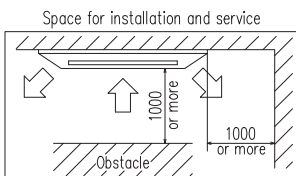
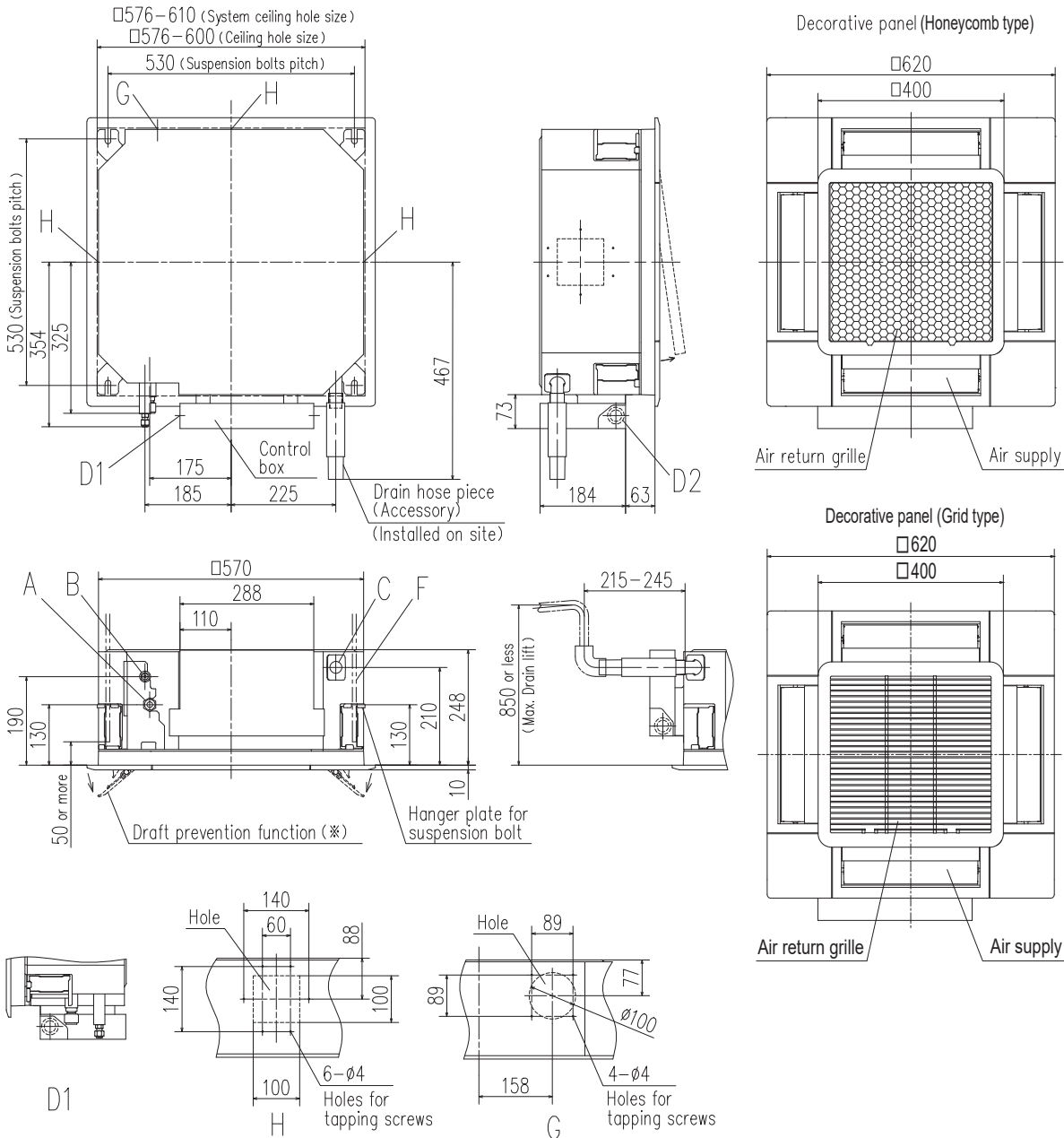

Make a space of 4000 or more between the units when installing more than one.

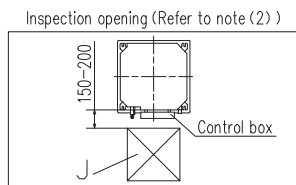

- Notes (1) The model name label is attached to the control box lid.  
(2) This unit is designed for 2x2 grid ceiling.  
If it is installed on a ceiling other than 2x2 grid ceiling, provide an inspection opening on the control box side.  
(3) Draft prevention function (※) is provided on the panel TC-PSAE-5AW-E, TC-PSAGE-5AW-E only.

Symbol	Content		
	Model	15,22,28	36,45,56
A	Gas piping	φ9.52 (3/8") (Flare)	φ12.7 (1/2") (Flare)
B	Liquid piping	φ6.35 (1/4") (Flare)	
C	Drain piping	VP25 (O.D.32)	
D1	Power source connection		
D2	Remote control code and signal wiring connection		
F	Suspension bolts	(M10 or M8)	
G	Outside air opening for ducting	(Knock out)	
H	Air outlet opening for ducting	φ125 (Knock out)	
J	Inspection opening	450X450	

# Ceiling Cassette -2way- FDTW

FDTW28KXZE3-W, FDTW45KXZE3-W, FDTW56KXZE3-W, FDTW71KXZE3-W  
FDTW28KXE6F, FDTW45KXE6F, FDTW56KXE6F, FDTW71KXE6F

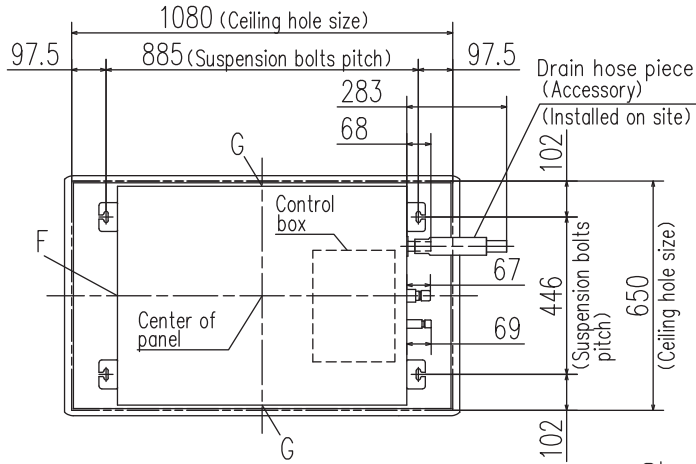

All measurements in mm.

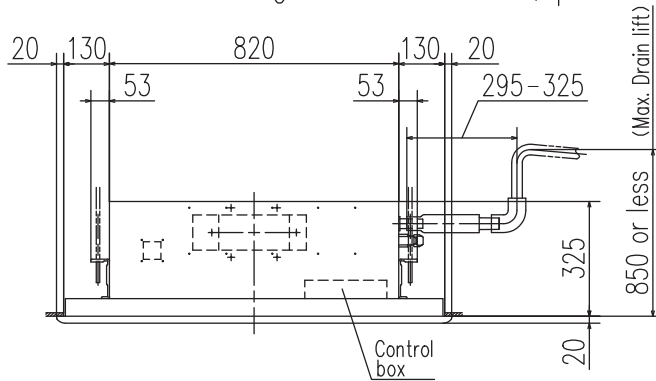
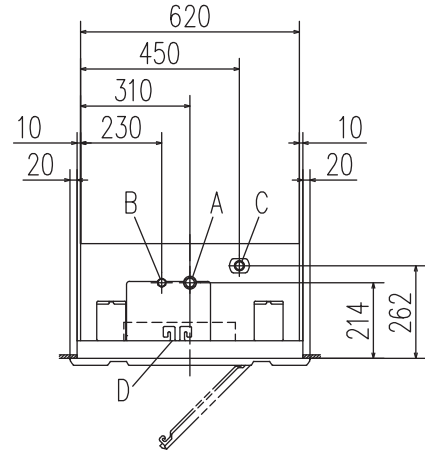

Decorative panel

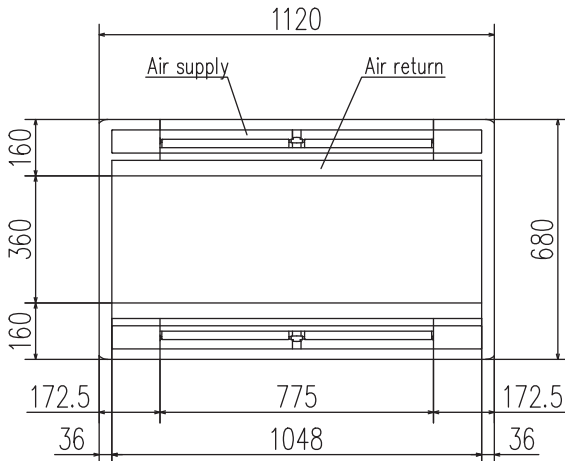
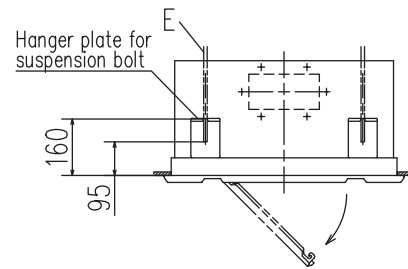

Space for installation and service

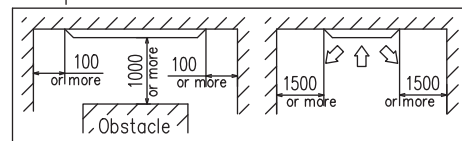

Make a space of 4000 or more between the units when installing more than one.

Symbol	Content			
	Model	28	45,56	71
A	Gas piping	∅9.52 (3/8") (Flare)	∅12.7 (1/2") (Flare)	∅15.88 (5/8") (Flare)
B	Liquid piping	∅6.35 (1/4") (Flare)		∅9.52 (3/8") (Flare)
C	Drain piping		VP25 (O.D.32)	
D	Hole for wiring			
E	Suspension bolts		M10	
F	Outside air opening for ducting		(Knock out)	
G	Air outlet opening for ducting		(Knock out)	

Notes (1) The model name label is attached on the lid of the control box.

# Ceiling Cassette -2way- FDTW

FDTW90KXZE3-W, FDTW112KXZE3-W, FDTW140KXZE3-W  
FDTW90KXE6F, FDTW112KXE6F, FDTW140KXE6F

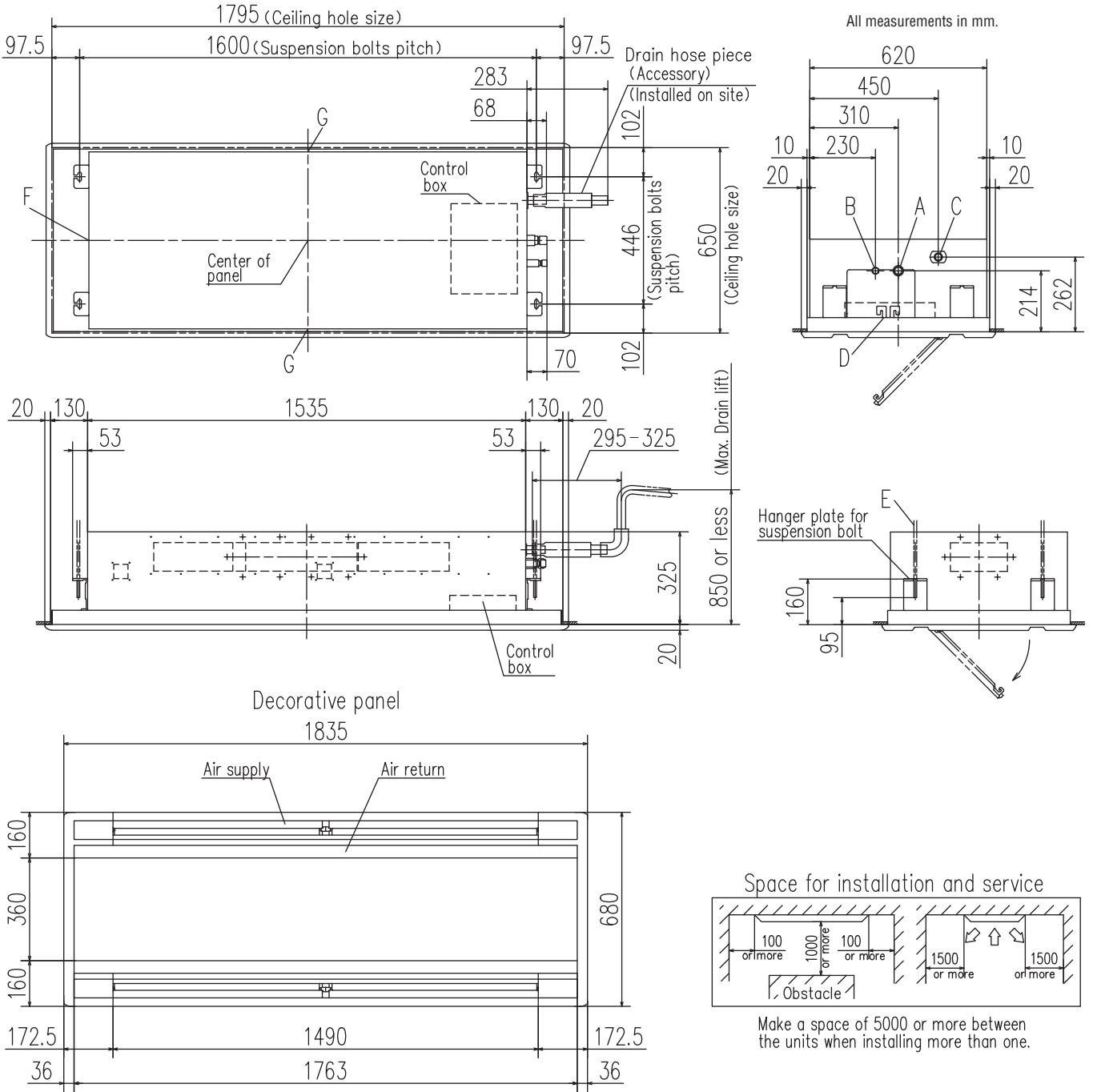

Symbol	Content	
A	Gas piping	φ15.88 (5/8") (Flare)
B	Liquid piping	φ9.52 (3/8") (Flare)
C	Drain piping	VP25 (O.D.32)
D	Hole for wiring	
E	Suspension bolts	M10
F	Outside air opening for ducting	(Knock out)
G	Air outlet opening for ducting	(Knock out)

Notes (1) The model name label is attached on the lid of the control box.

# Ceiling Cassette -1way- FDTS

FDTS45KXZE3-W, FDTS71KXZE3-W  
FDTS45KXE6F, FDTS71KXE6F

All measurements in mm.

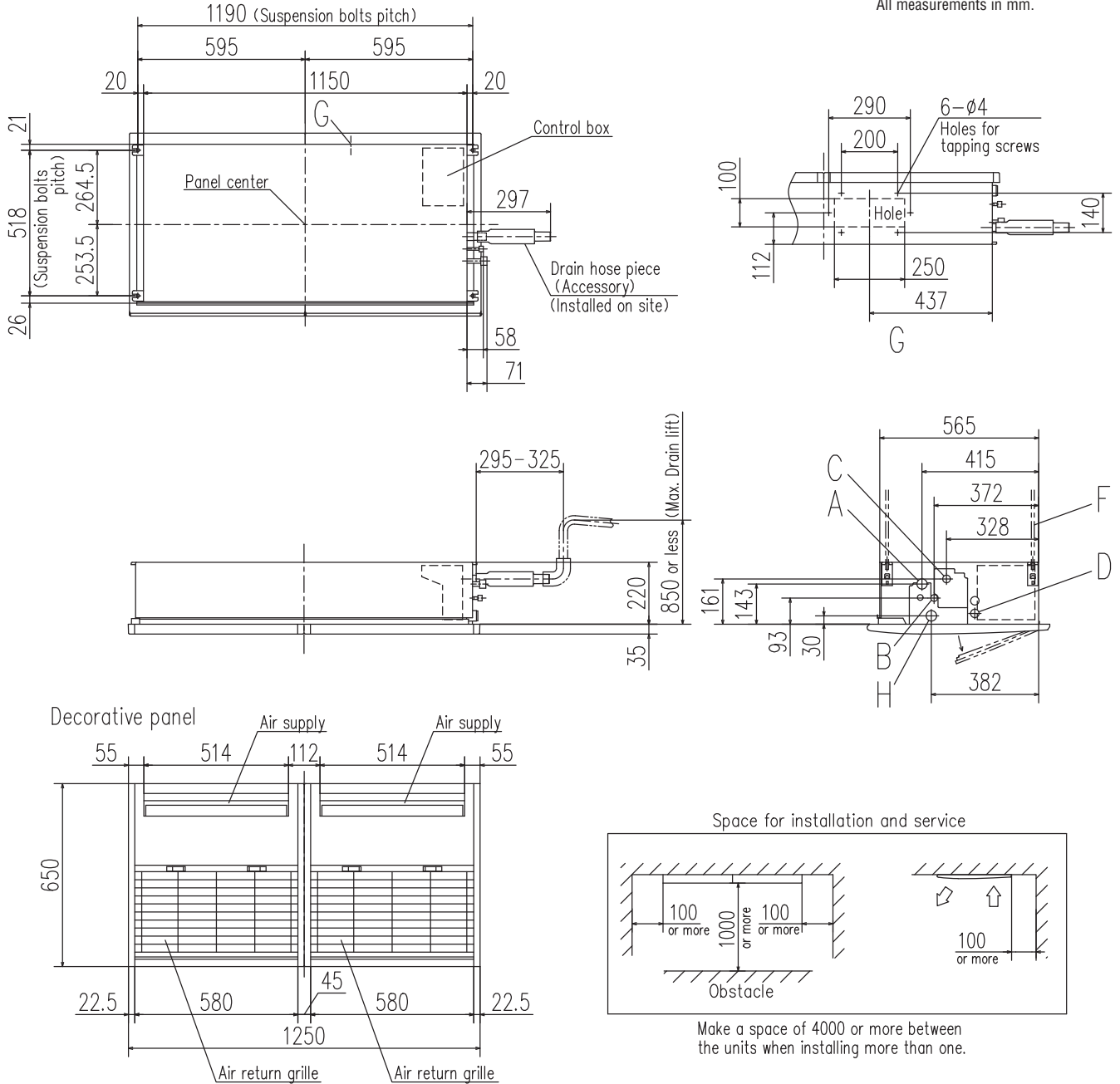

Symbol	Content		
	Model	45,50	71
A	Gas piping	ø12.7 (1/2") (Flare)	ø15.88 (5/8") (Flare)
B	Liquid piping	ø6.35 (1/4") (Flare)	ø9.52 (3/8") (Flare)
C	Drain piping	VP25 (I.D.25 , O.D.32) Note (2)	
D	Hole for wiring		
F	Suspension bolts	(M10)	
G	Outside air opening for ducting	(Knock out)	
H	Drain piping (Gravity drainage)	VP25 (I.D.25 , O.D.32)	

Notes (1) The model name label is attached inside the air return grille.

(2) This unit is designed for 2x4 grid ceiling.

# Ceiling Cassette -1way Compact-FDTQ

FDTQ22KXZE3-W, FDTQ28KXZE3-W, FDTQ36KXZE3-W  
 FDTQ22KXE6F, FDTQ28KXE6F, FDTQ36KXE6F

All measurements in mm.

Direct blow panel (TQ-PSA-15W-E)

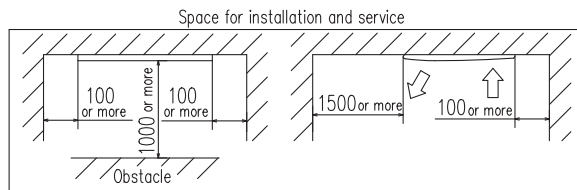
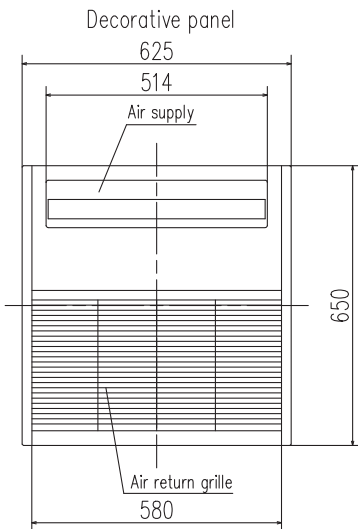
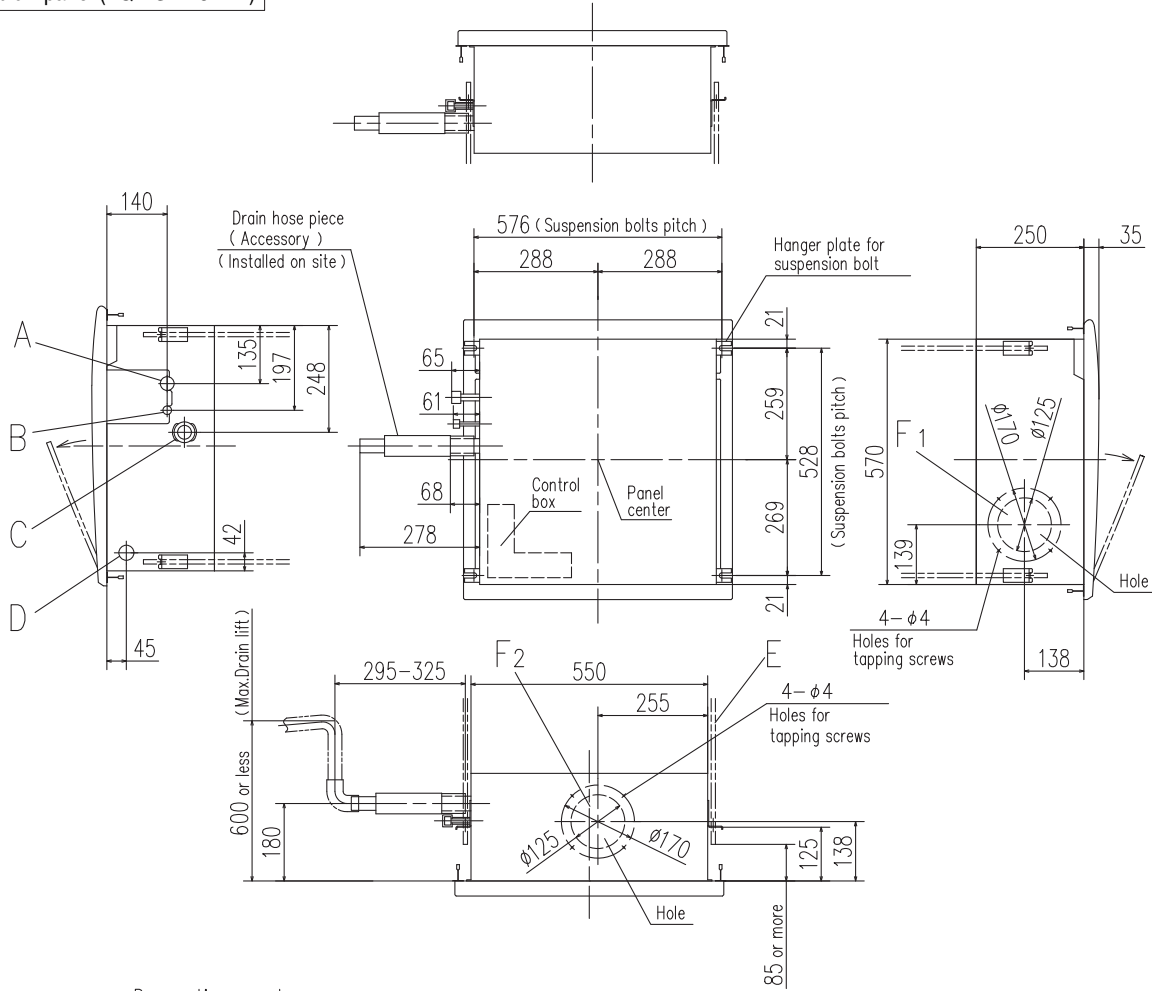

Make a space of 3000 or more between the units when installing more than one.

Notes

- (1) The model name label is attached on the fan case inside the air return grille.
- (2) This unit is designed for 2X2 grid ceiling.

Symbol	Content		
	Model	22,28	36
A	Gas piping	$\phi 9.52$ (3/8") (Flare)	$\phi 12.7$ (1/2") (Flare)
B	Liquid piping	$\phi 6.35$ (1/4") (Flare)	
C	Drain piping	VP25 (O.D.32)	
D	Hole for wiring	$\phi 30$	
E	Suspension bolts	M10	
F 1,2	Outside air opening for ducting	(Knock out)	

# Ceiling Cassette -1way Compact-FDTQ

FDTQ22KXZE3-W, FDTQ28KXZE3-W, FDTQ36KXZE3-W  
 FDTQ22KXE6F, FDTQ28KXE6F, FDTQ36KXE6F

All measurements in mm.

Direct blow panel (TQ-PSB-15W-E)

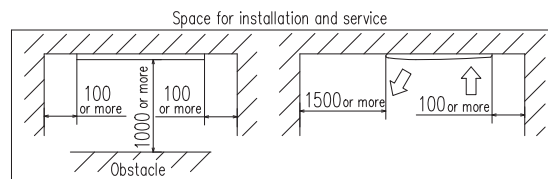
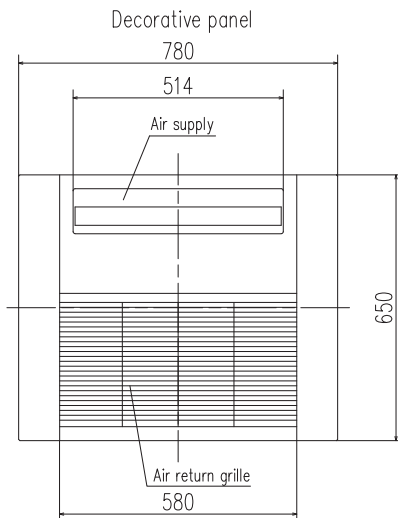
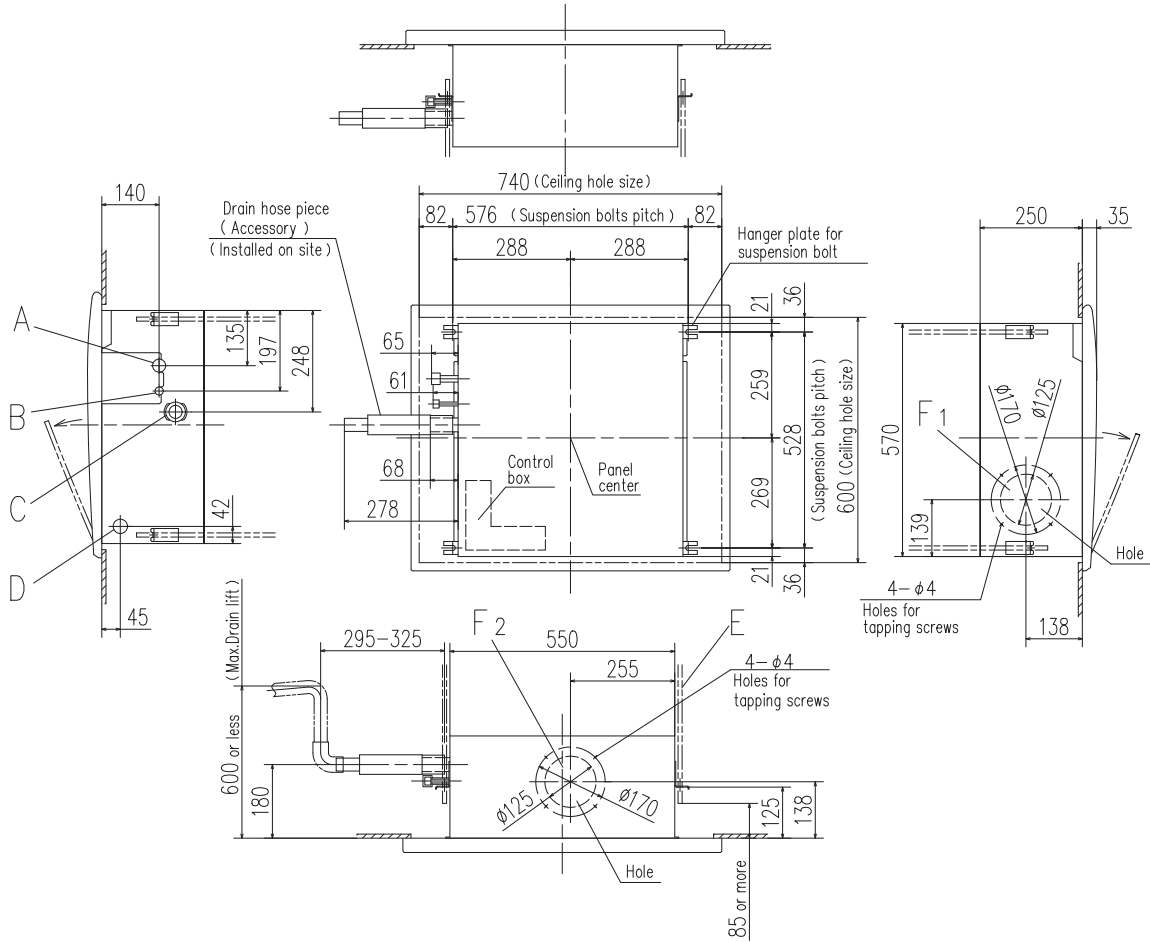

Make a space of 3000 or more between the units when installing more than one.

Notes

- (1) The model name label is attached on the fan case inside the air return grille.

Symbol	Content		
	Model	22,28	36
A	Gas piping	Ø9.52 (3/8") (Flare)	Ø12.7 (1/2") (Flare)
B	Liquid piping	Ø6.35 (1/4") (Flare)	
C	Drain piping	VP25 (O.D.32)	
D	Hole for wiring	Ø30	
E	Suspension bolts	M10	
F 1,2	Outside air opening for ducting	(Knock out)	

# Duct Connected -High Static Pressure- FDU

FDU45KXE3-W, FDU56KXE3-W  
FDU45KXE6F, FDU56KXE6F

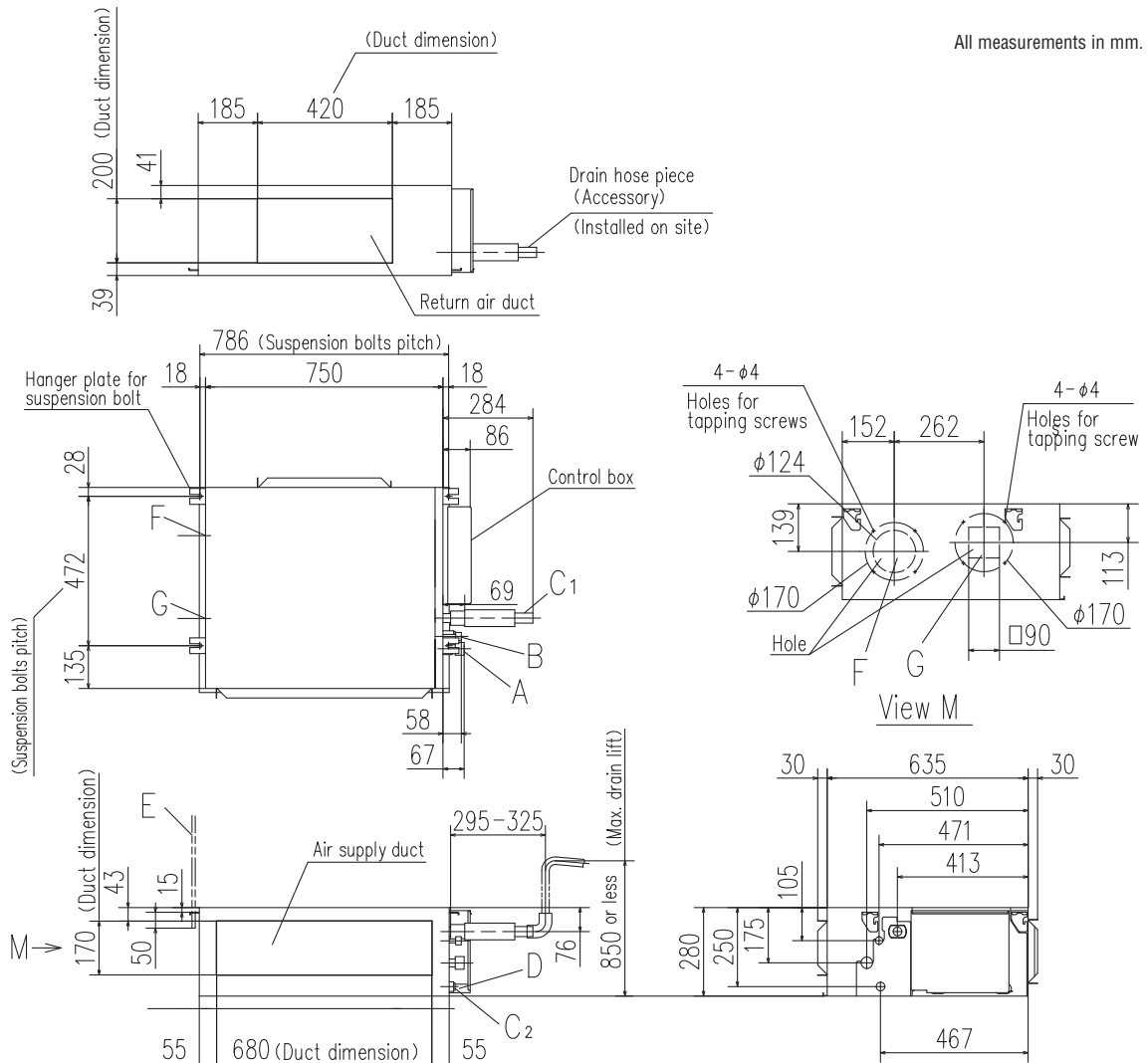

All measurements in mm.

### Space for installation and service

Select either of two cases to keep space for installation and services.  
(Case 1) From side of unit

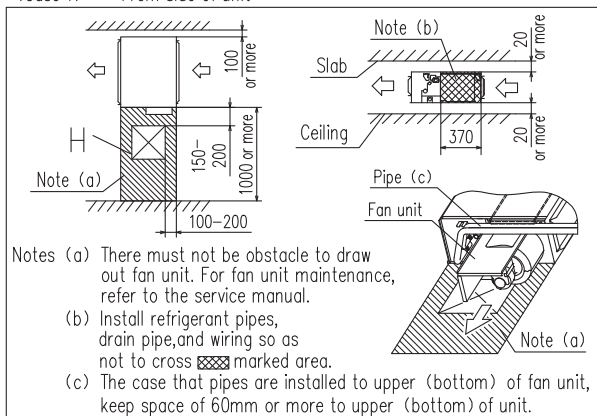

Symbol	Content	
A	Gas piping	φ12.7 (1/2") (Flare)
B	Liquid piping	φ6.35 (1/4") (Flare)
C1	Drain piping	VP25 (O.D.32)
C2	Drain piping (Gravity drainage)	VP20 (O.D.26)
D	Hole for wiring	
E	Suspension bolts	M10
F	Outside air opening for ducting	(Knock out)
G	Air outlet opening for ducting	(Knock out)
H	Inspection opening	(450X450)

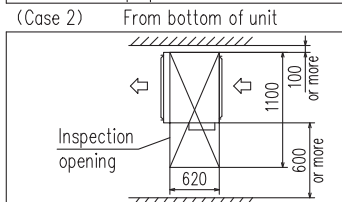

Note  
(1) The model name label is attached on the lid of the control box.

# Duct Connected -High Static Pressure- FDU

FDU71KXZE3-W, FDU90KXZE3-W  
FDU71KXE6F, FDU90KXE6F

All measurements in mm.

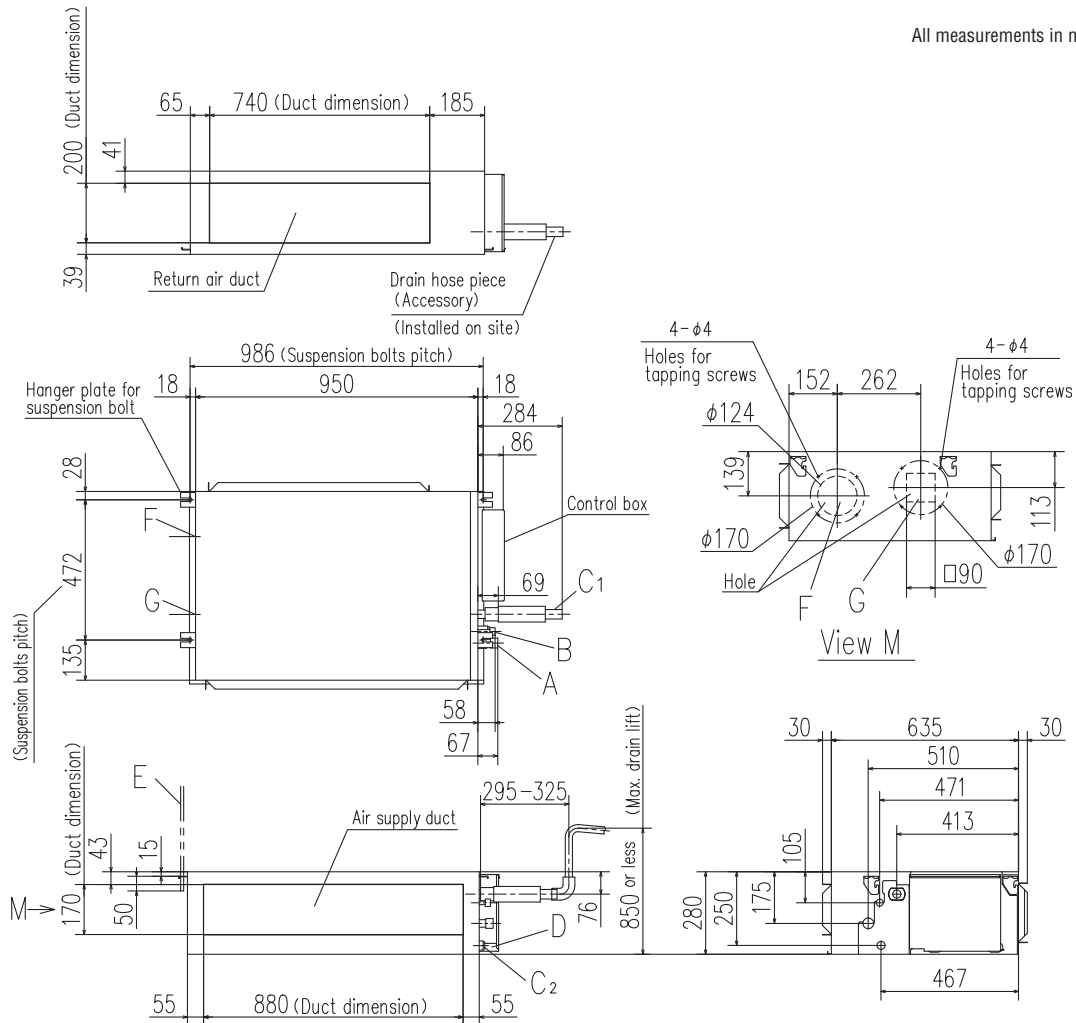

### Space for installation and service

Select either of two cases to keep space for installation and services.  
(Case 1) From side of unit

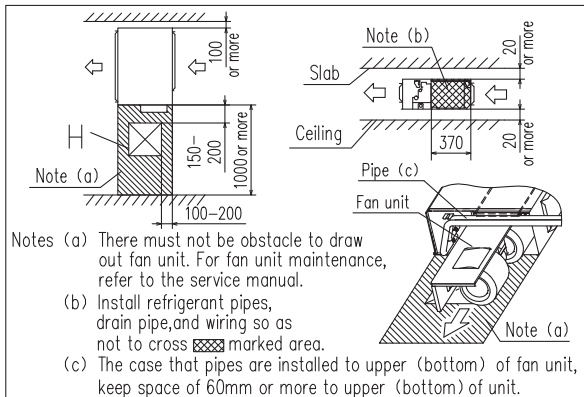

### (Case 2) From bottom of unit

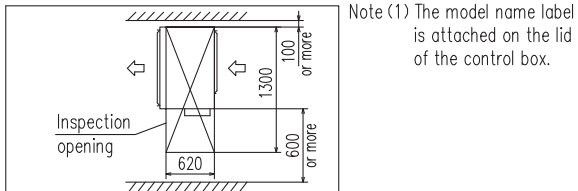

Symbol	Content	
A	Gas piping	φ15.88 (5/8") (Flare)
B	Liquid piping	φ9.52 (3/8") (Flare)
C1	Drain piping	VP25 (O.D.32)
C2	Drain piping (Gravity drainage)	VP20 (O.D.26)
D	Hole for wiring	
E	Suspension bolts	M10
F	Outside air opening for ducting	(Knock out)
G	Air outlet opening for ducting	(Knock out)
H	Inspection opening	(450X450)

# Duct Connected -High Static Pressure- FDU

FDU112KXZE3-W, FDU140KXZE3-W, FDU160KXZE3-W  
FDU112KXE6F, FDU140KXE6F, FDU160KXE6F

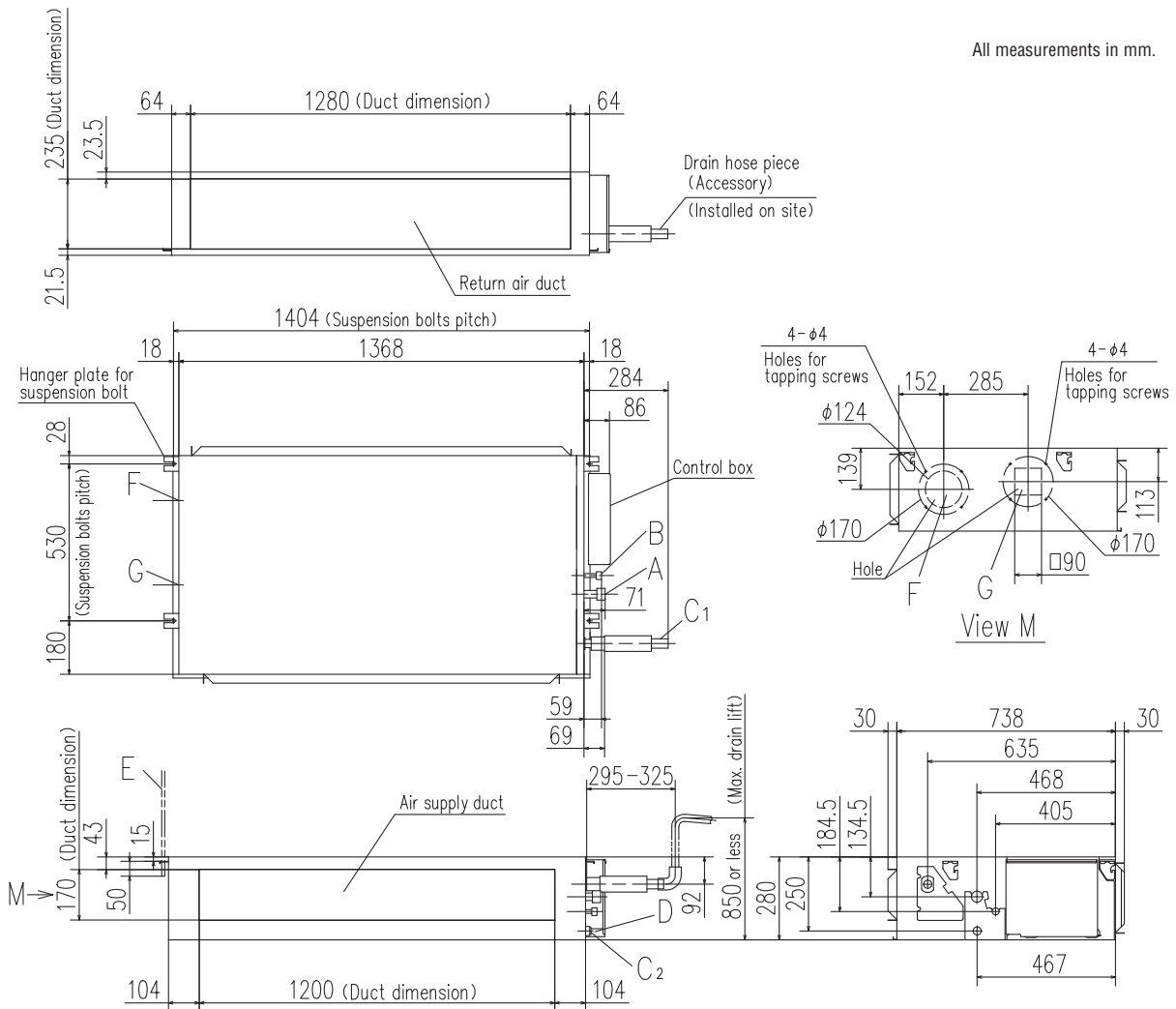

All measurements in mm.

### Space for installation and service

Select either of two cases to keep space for installation and services.  
(Case 1) From side of unit

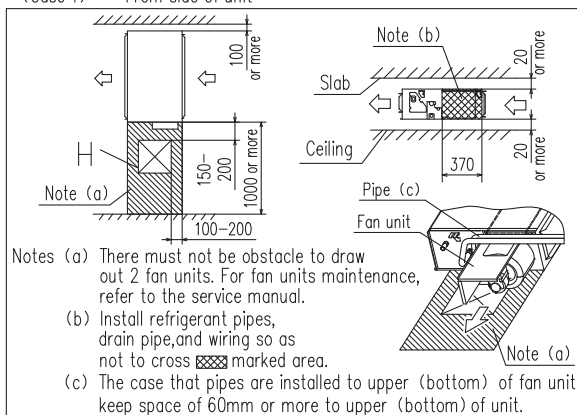

Symbol	Content	
A	Gas piping	φ15.88 (5/8") (Flare)
B	Liquid piping	φ9.52 (3/8") (Flare)
C1	Drain piping	VP25 (O.D.32)
C2	Drain piping (Gravity drainage)	VP20 (O.D.26)
D	Hole for wiring	
E	Suspension bolts	M10
F	Outside air opening for ducting	( Knock out)
G	Air outlet opening for ducting	( Knock out)
H	Inspection opening	(450X450)

### (Case 2) From bottom of unit

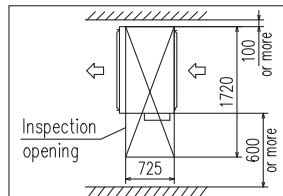

### Note

(1) The model name label is attached on the lid of the control box.

# Duct Connected -High Static Pressure- FDU

FDU224KXZE3-W, FDU280KXZE3-W  
FDU224KXZE1, FDU280KXZE1

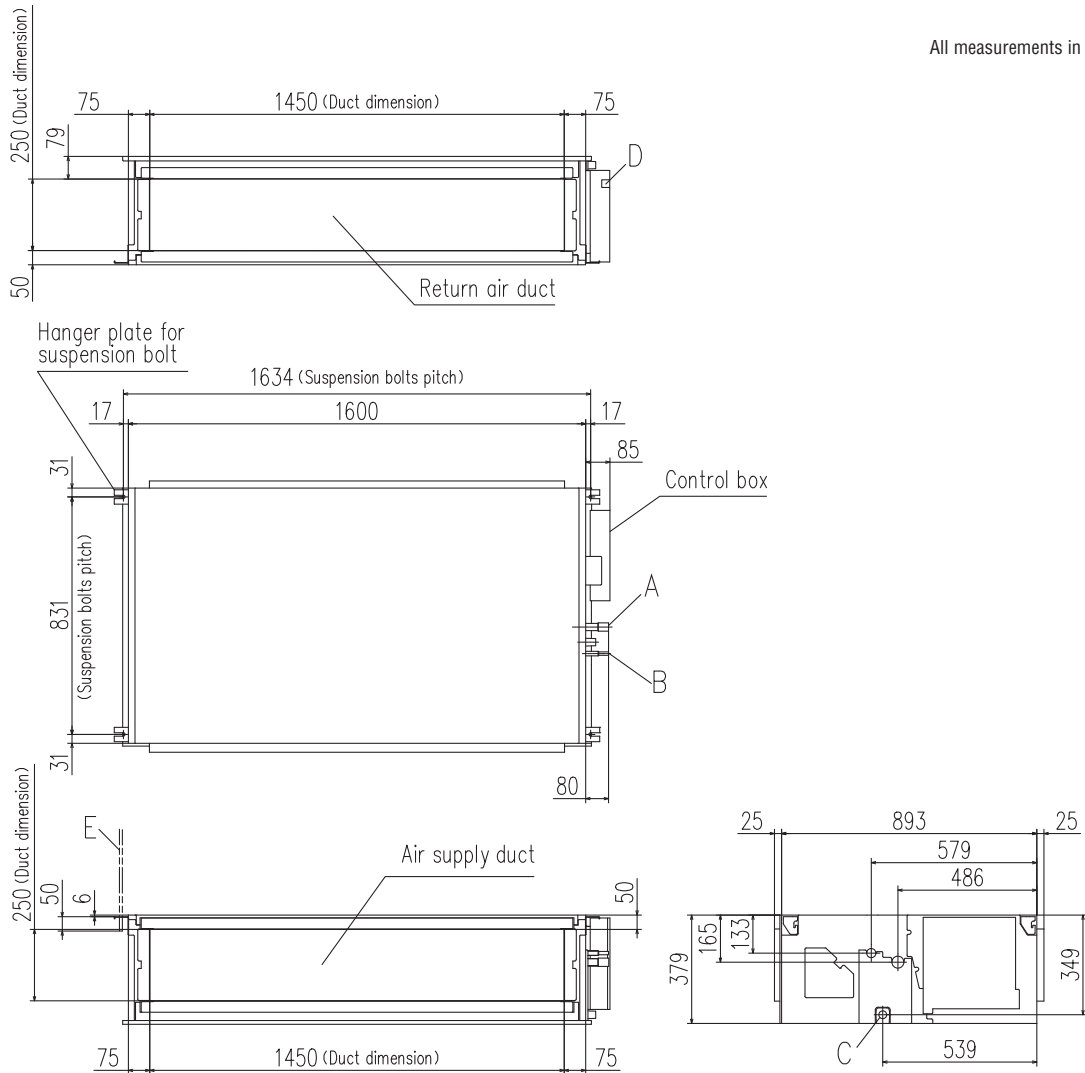

All measurements in mm.

## Space for installation and service

Select either of two cases to keep space for installation and services.  
(Case 1) From side of unit

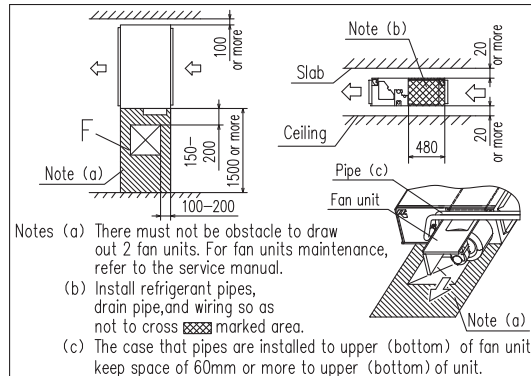

Symbol	Content		
	MODEL	224	280
A	Gas piping	φ19.05 (3/4") (Brazing)	φ22.22 (7/8") (Brazing)
B	Liquid piping	φ9.52 (3/8") (Brazing)	
C	Drain piping (Gravity drainage)	VP25 (O.D.32)	
D	Hole for wiring		
E	Suspension bolts	M10	
F	Inspection hole	(450X450)	

## (Case 2) From bottom of unit

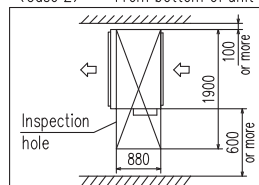

Notes (1) The model name label is attached on the lid of the control box.

# Duct Connected -Low/Middle Static Pressure- FDUM

FDUM22KXZE3-W, FDUM28KXZE3-W, FDUM36KXZE3-W, FDUM45KXZE3-W, FDUM56KXZE3-W  
FDUM22KXE6F, FDUM28KXE6F, FDUM36KXE6F, FDUM45KXE6F, FDUM56KXE6F

All measurements in mm.

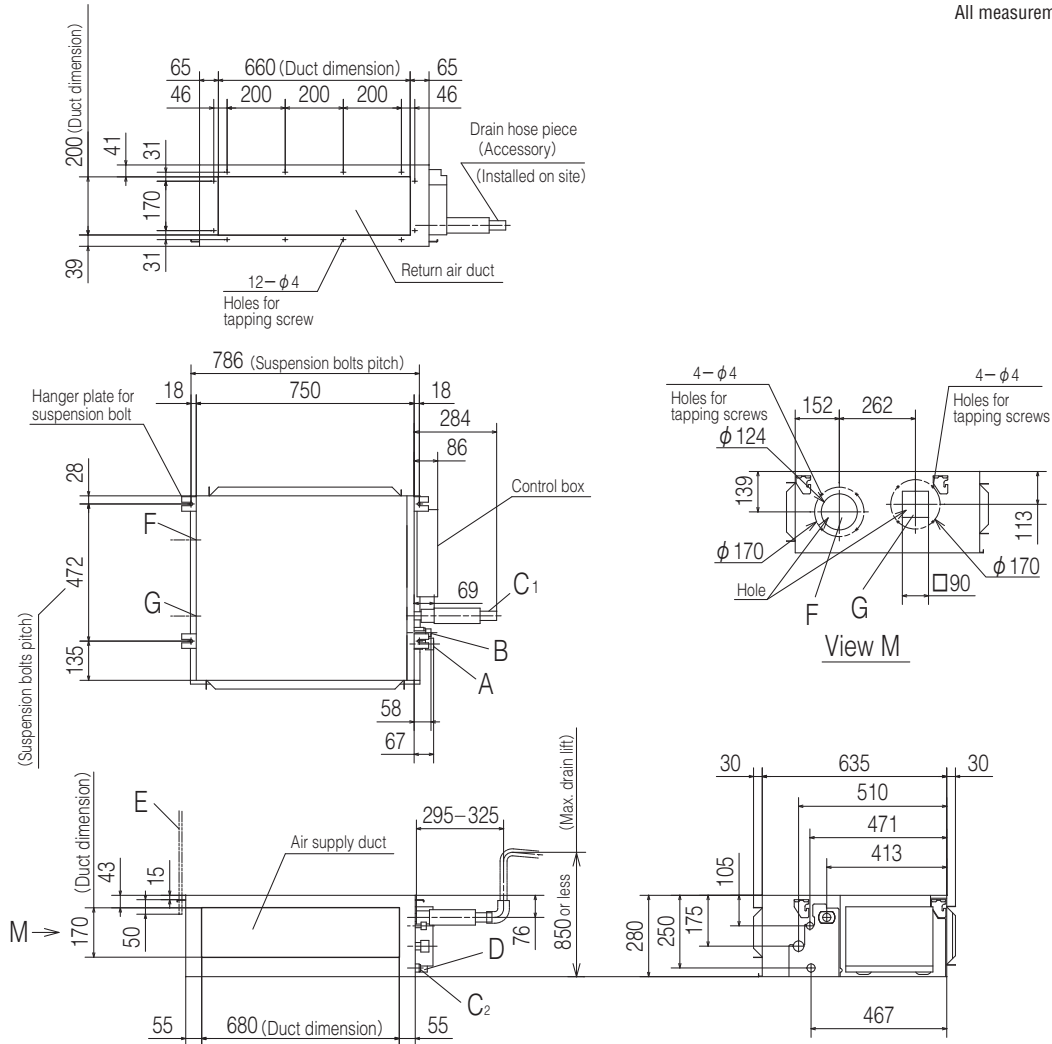

### Space for installation and service

Select either of two cases to keep space for installation and services.

(Case 1) From side of unit

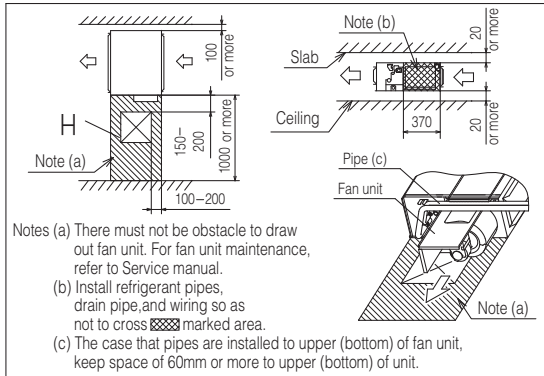

(Case 2) From bottom of unit

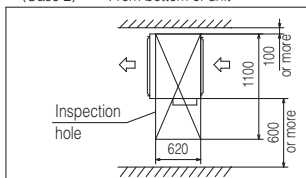

Symbol	Content	
	Model	22,28 36,45,56
A	Gas piping	φ9.52(3/8") (Flare) φ12.7(1/2") (Flare)
B	Liquid piping	φ6.35(1/4") (Flare)
C1	Drain piping	VP25 (O.D.32)
C2	Drain piping (Gravity drainage)	VP20 (O.D.26)
D	Hole for wiring	(M10)
E	Suspension bolts	(M10)
F	Outside air opening for ducting	(φ150) (Knock out)
G	Air outlet opening for ducting	(φ125) (Knock out)
H	Inspection hole	(450X450)

Note The model name label is attached on the lid of the control box.

# Duct Connected -Low/Middle Static Pressure- FDUM

FDUM71KXZE3-W, FDUM90KXZE3-W  
FDUM71KXE6F, FDUM90KXE6F

All measurements in mm.

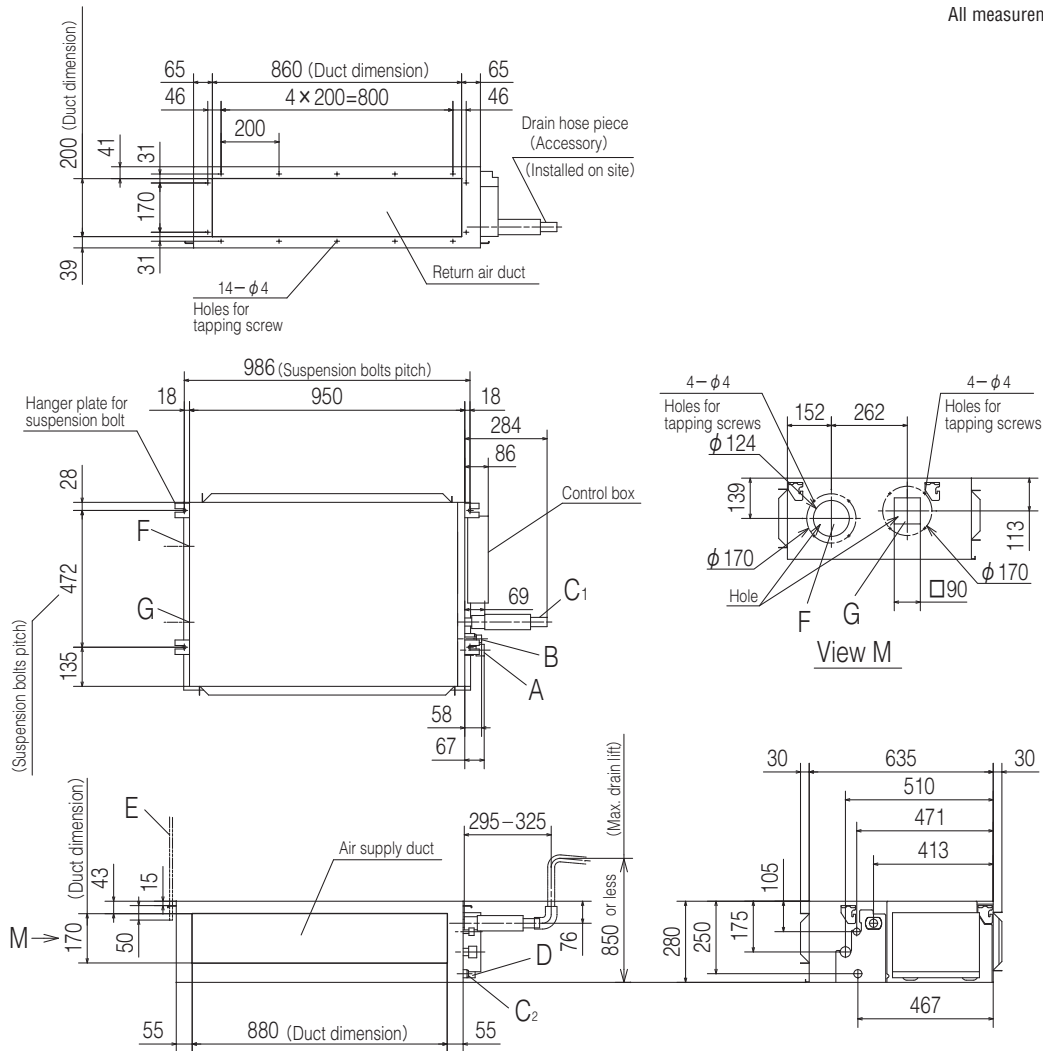

## Space for installation and service

Select either of two cases to keep space for installation and services.

(Case 1) From side of unit

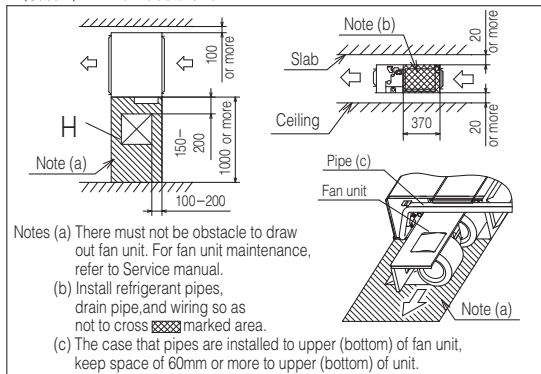

Symbol	Content	
A	Gas piping	φ 15.88(5/8" )(Flare)
B	Liquid piping	φ 9.52(3/8" )(Flare)
C1	Drain piping	VP25 (O.D.32)
C2	Drain piping (Gravity drainage)	VP20 (O.D.26)
D	Hole for wiring	
E	Suspension bolts	(M10)
F	Outside air opening for ducting	(φ 150)(Knock out)
G	Air outlet opening for ducting	(φ 125)(Knock out)
H	Inspection hole	(450X450)

Note The model name label is attached on the lid of the control box.

(Case 2) From bottom of unit

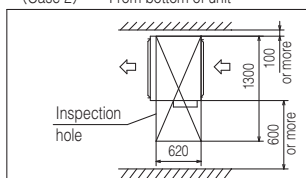

# Duct Connected -Low/Middle Static Pressure- FDUM

FDUM112KXZE3-W, FDUM140KXZE3-W, FDUM160KXZE3-W  
FDUM112KXE6F, FDUM140KXE6F, FDUM160KXE6F

All measurements in mm.

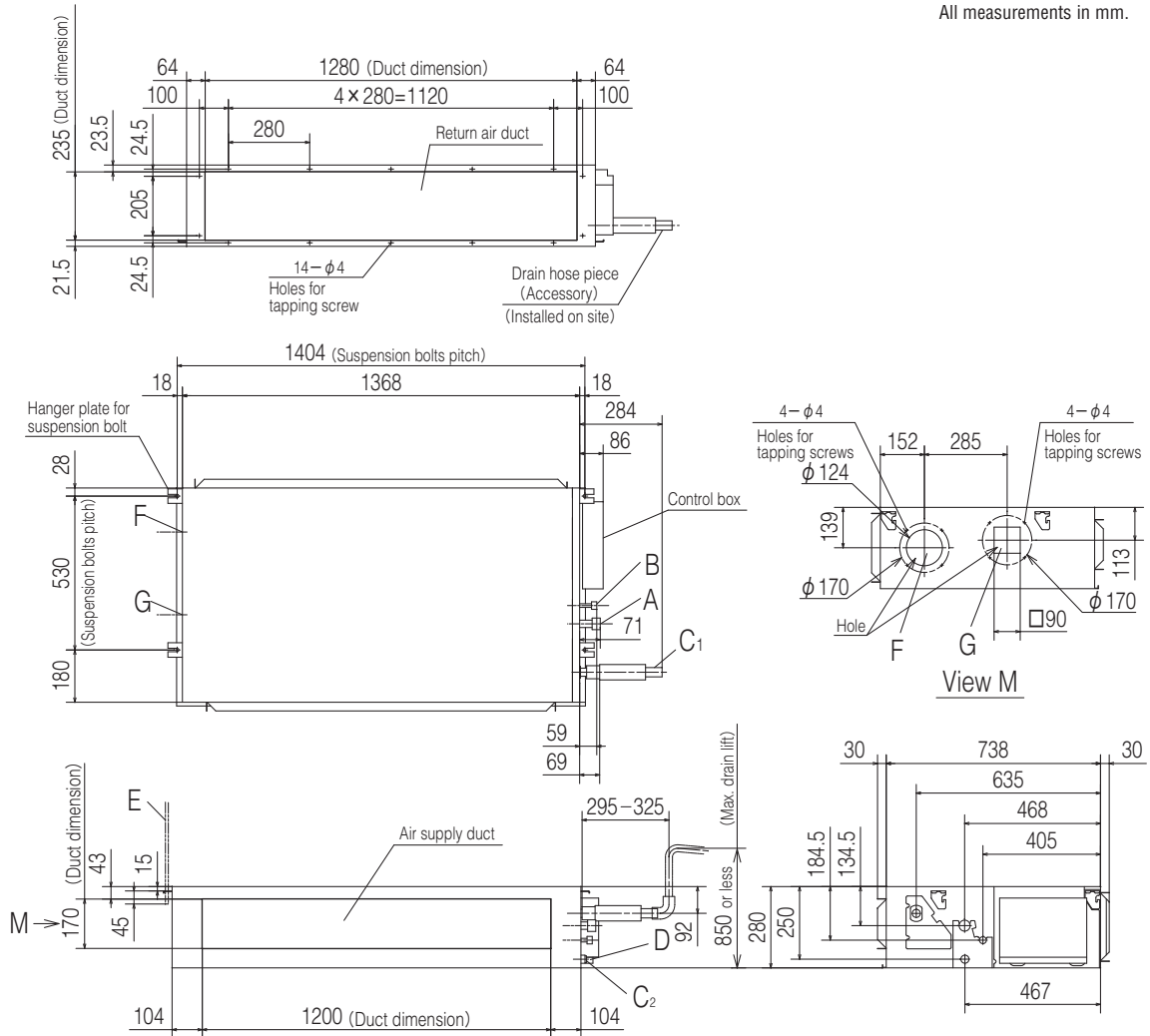

### Space for installation and service

Select either of two cases to keep space for installation and services.  
(Case 1) From side of unit

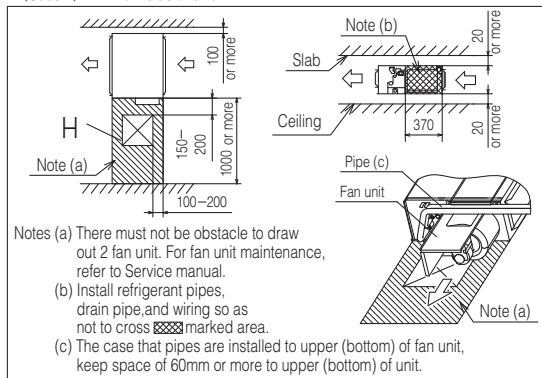

Symbol	Content	
A	Gas piping	φ 15.88 (5/8") (Flare)
B	Liquid piping	φ 9.52 (3/8") (Flare)
C1	Drain piping	VP25 (O.D.32)
C2	Drain piping (Gravity drainage)	VP20 (O.D.26)
D	Hole for wiring	
E	Suspension bolts	(M10)
F	Outside air opening for ducting	(φ 150) ( Knock out)
G	Air outlet opening for ducting	(φ 125) ( Knock out)
H	Inspection hole	(450X450)

Note The model name label is attached on the lid of the control box.

### (Case 2) From bottom of unit

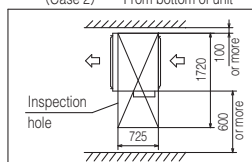

# Duct Connected (thin) -Low Static Pressure- FDUT

FDUT15KXZE3-W, FDUT22KXZE3-W, FDUT28KXZE3-W, FDUT36KXZE3-W  
FDUT15KXE6F-E, FDUT22KXE6F-E, FDUT28KXE6F-E, FDUT36KXE6F-E

All measurements in mm.

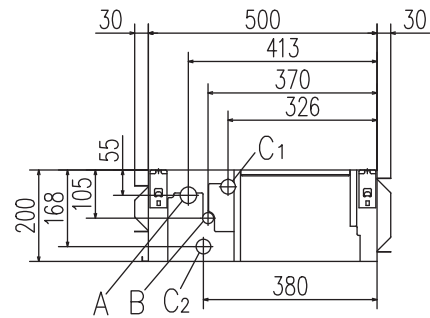
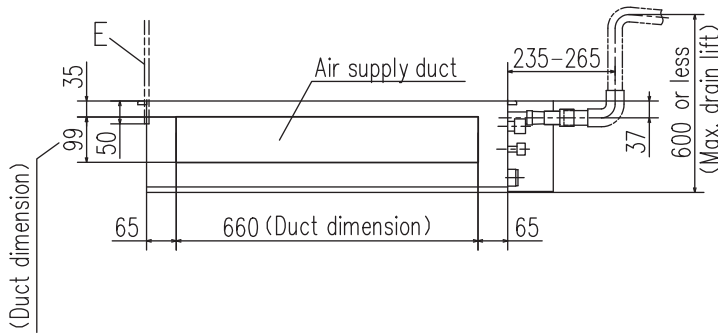
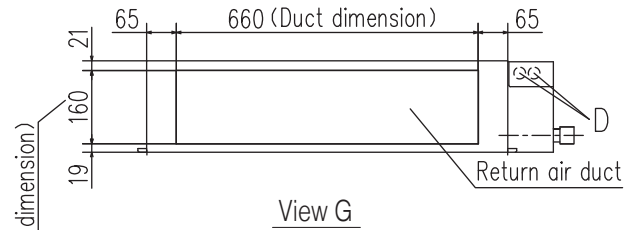
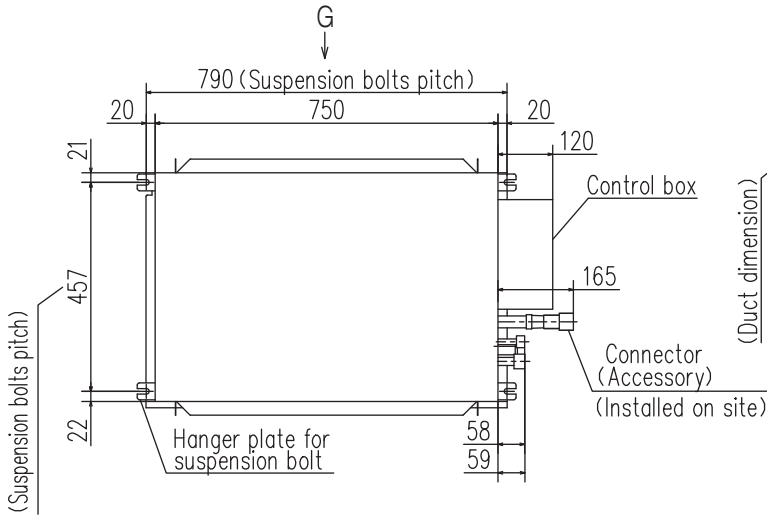

Space for installation and service

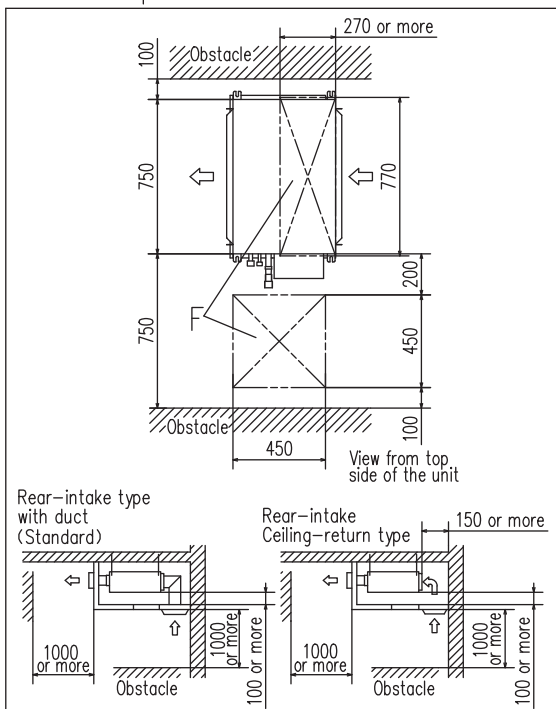

Symbol	Content		
	Model	15,22,28	36
A	Gas piping	φ9.52 (3/8") (Flare)	φ12.7 (1/2") (Flare)
B	Liquid piping	φ6.35 (1/4") (Flare)	
C1	Drain piping	VP25 (O.D.32) (Used with attached connector)	
C2	Drain piping (Gravity drainage)	VP25 (O.D.32) (Used with attached connector)	
D	Hole for wiring	φ25 x 2	
E	Suspension bolts	M10	
F	Inspection opening	(450X450), (270X770)	

Note The model name label is attached on the lid of the control box.

# Duct Connected (thin) -Low Static Pressure- FDUT

FDUT45KXZE3-W, FDUT56KXZE3-W  
FDUT45KXE6F-E, FDUT56KXE6F-E

All measurements in mm.

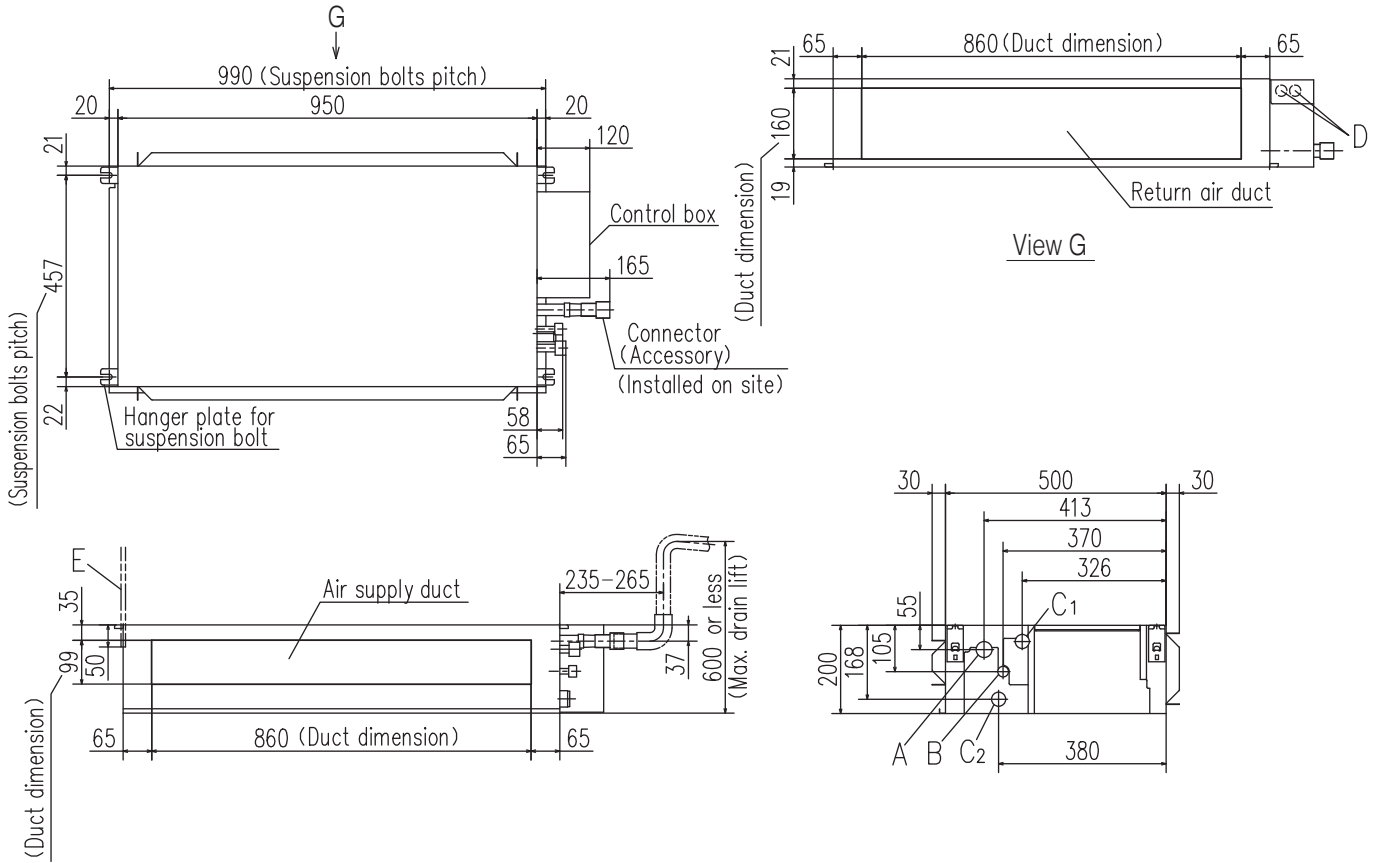

Symbol	Model	Content
		45,56
A	Gas piping	φ12.7 (1/2") (Flare)
B	Liquid piping	φ6.35 (1/4") (Flare)
C1	Drain piping	VP25 (O.D.32) (Used with attached connector)
C2	Drain piping (Gravity drainage)	VP25 (O.D.32) (Used with attached connector)
D	Hole for wiring	φ25 x 2
E	Suspension bolts	M10
F	Inspection opening	(450X450), (270X970)

Note The model name label is attached on the lid of the control box.

## Space for installation and service

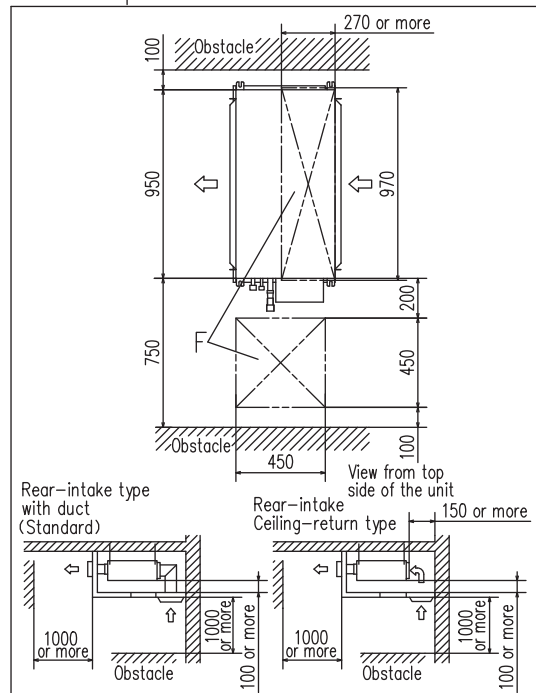



# Duct Connected (Compact & Flexible)

## FDUH

FDUH22KXZE3-W, FDUH28KXZE3-W, FDUH36KXZE3-W  
 FDUH22KXE6F, FDUH28KXE6F, FDUH36KXE6F

All measurements in mm.

Rear air return type

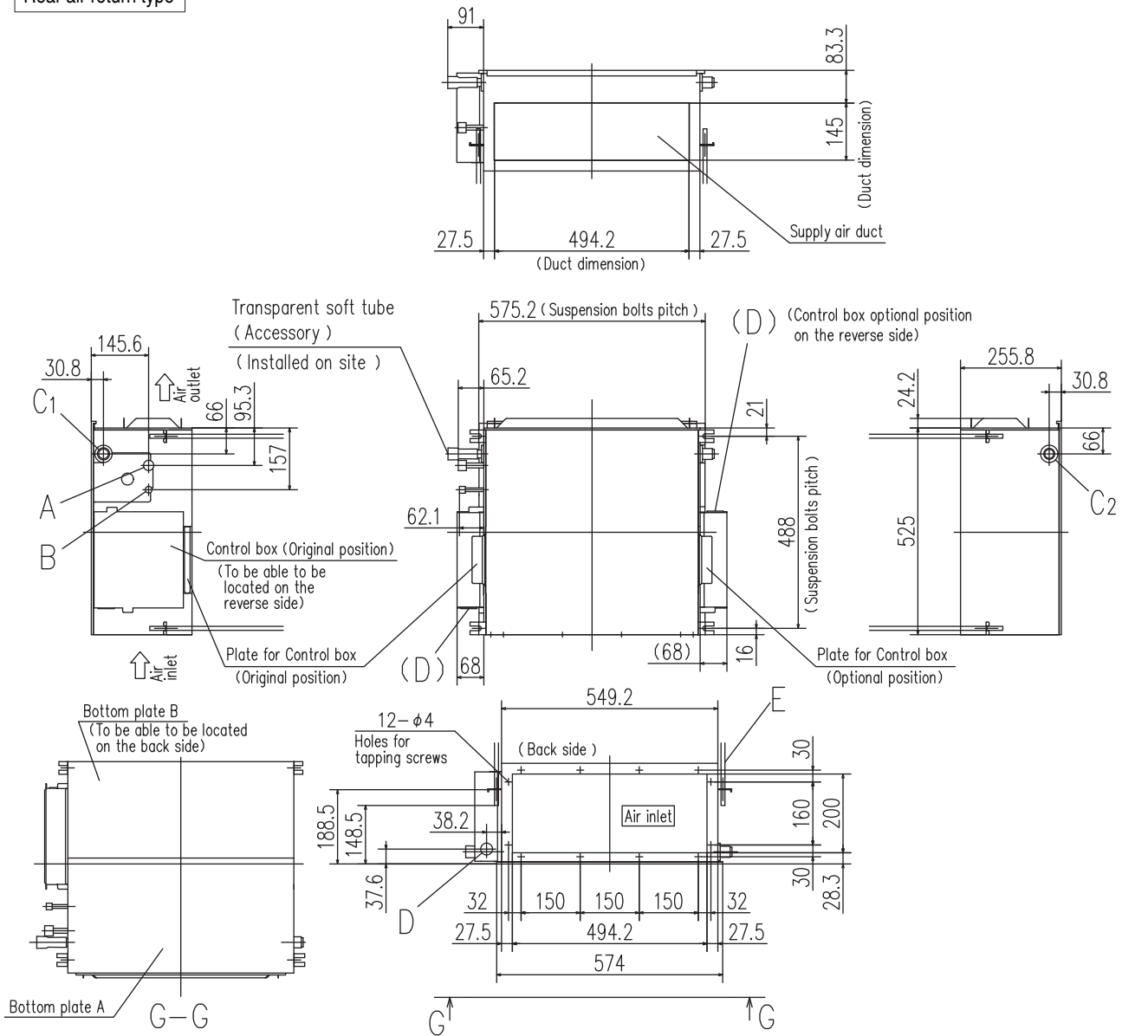

Symbol	Content		
	Model	22,28	36
A	Gas piping	φ9.52 (3/8") (Flare)	φ12.7 (1/2") (Flare)
B	Liquid piping	φ6.35 (1/4") (Flare)	
C1	Drain piping	VP20 (I.D.20, O.D.26) Note (2)	
C2	Drain piping	To be used instead of "C1"	
D	Hole for wiring	φ30	
E	Suspension bolts	(M10)	
F	Inspection hole	(590X1150) Note (3)	

- Notes
- (1) The model name label is attached on the fan case inside the air return grille.
  - (2) Prepare the connecting socket (VP20) on site.  
(As for drain piping, it is possible to choose C1 or C2)
  - (3) When control box is located on the reverse side, installation space should be modified new location.

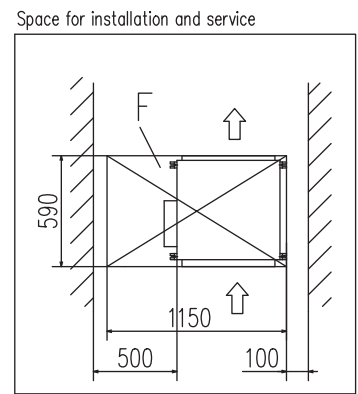

# Duct Connected (Compact & Flexible)

## FDUH

FDUH22KXZE3-W, FDUH28KXZE3-W, FDUH36KXZE3-W  
 FDUH22KXE6F, FDUH28KXE6F, FDUH36KXE6F

All measurements in mm.

Bottom suction type

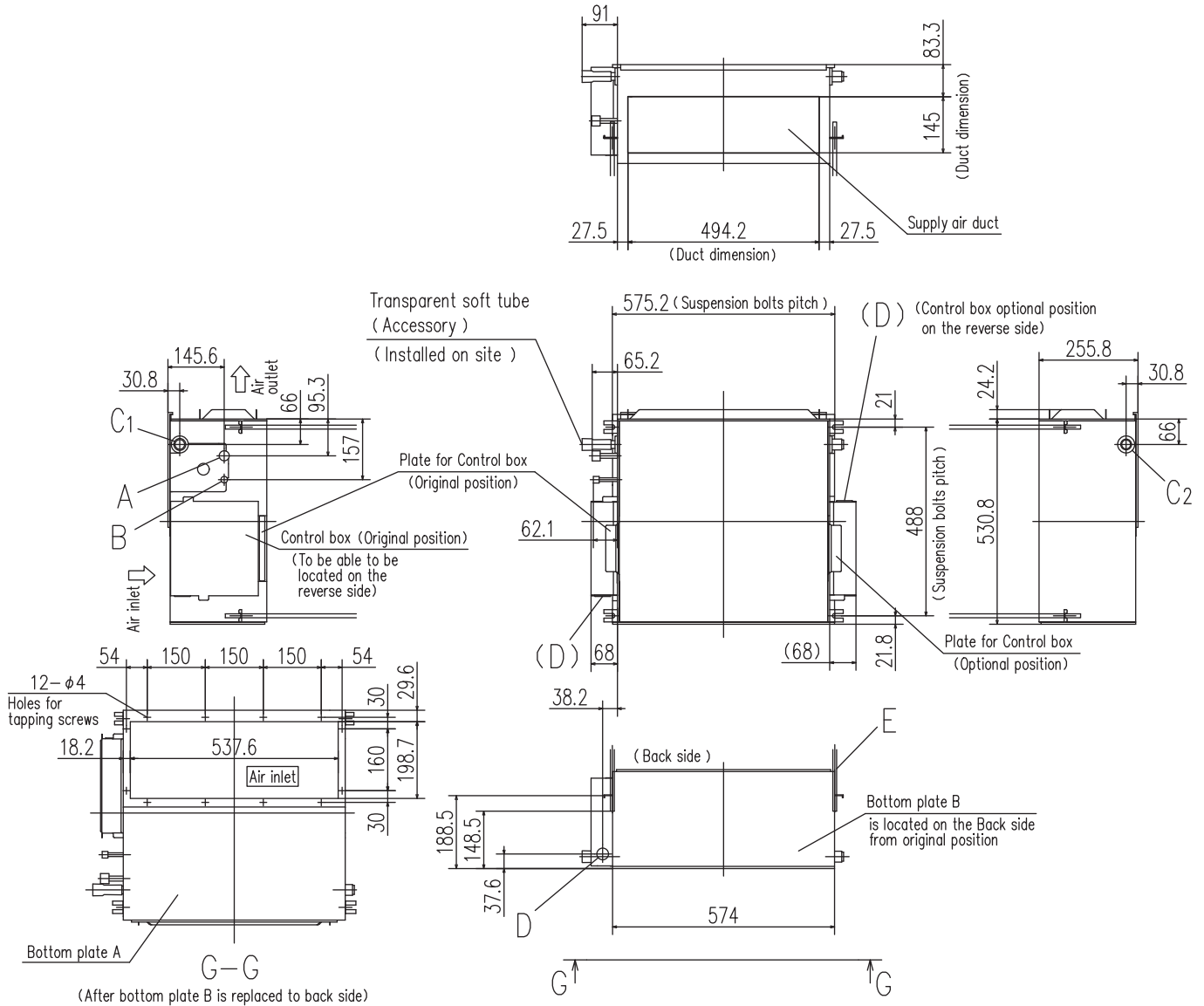

Symbol	Content		
	Model	22,28	36
A	Gas piping	φ9.52 (3/8") (Flare)	φ12.7 (1/2") (Flare)
B	Liquid piping	φ6.35 (1/4") (Flare)	
C1	Drain piping	VP20 Note (2)	
C2	Drain piping	To be used instead of "C1"	
D	Hole for wiring	φ30	
E	Suspension bolts	(M10)	
F	Inspection hole	(555X1150) Note (3)	

### Notes

- (1) The model name label is attached on the fan case inside the air return grille.
- (2) Prepare the connecting socket (VP20) on site.  
(As for drain piping, it is possible to choose C1 or C2)
- (3) When control box is located on the reverse side, installation space should be modified new location.

### Space for installation and service

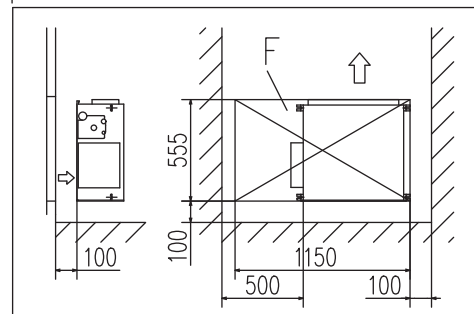



# Ceiling Suspended FDE

FDE36KXZE3-W, FDE45KXZE3-W, FDE56KXZE3-W  
FDE36KXZE1, FDE45KXZE1, FDE56KXZE1

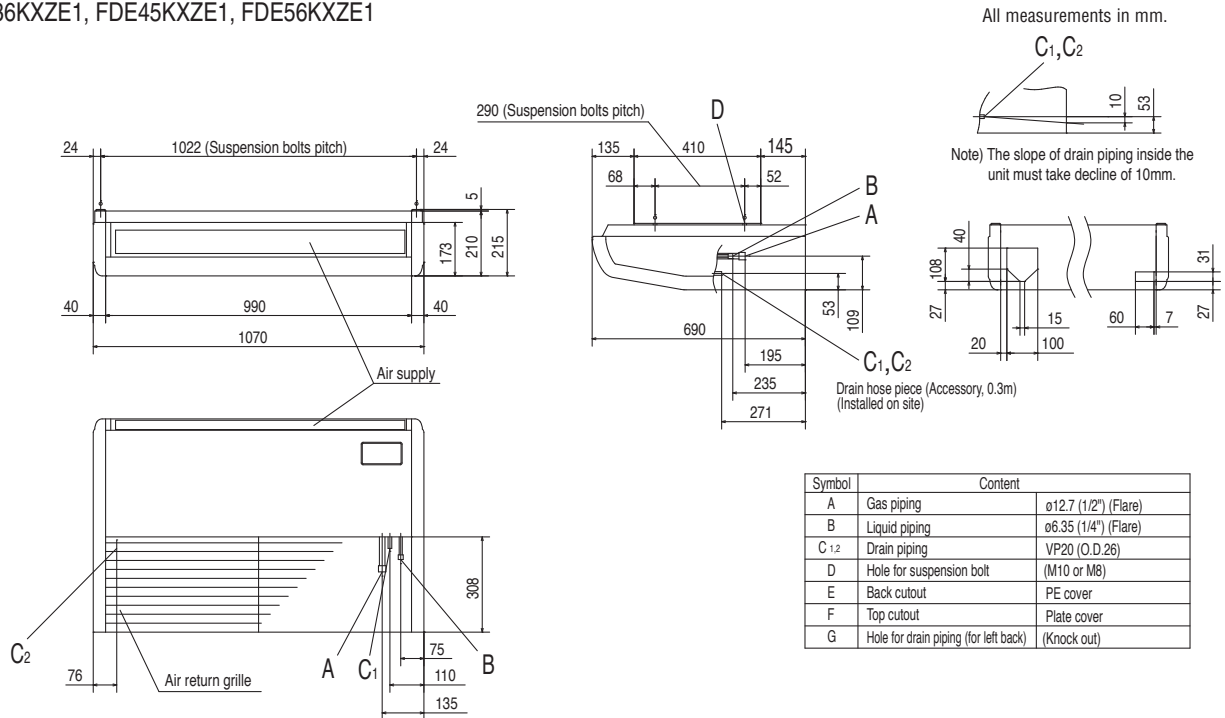

FDE71KXZE3-W  
FDE71KXZE1

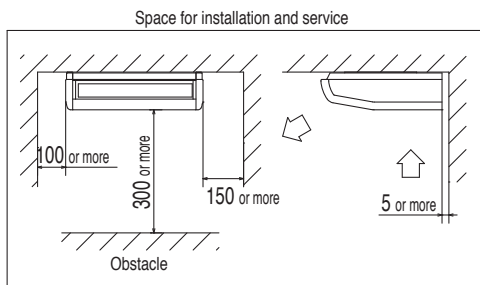
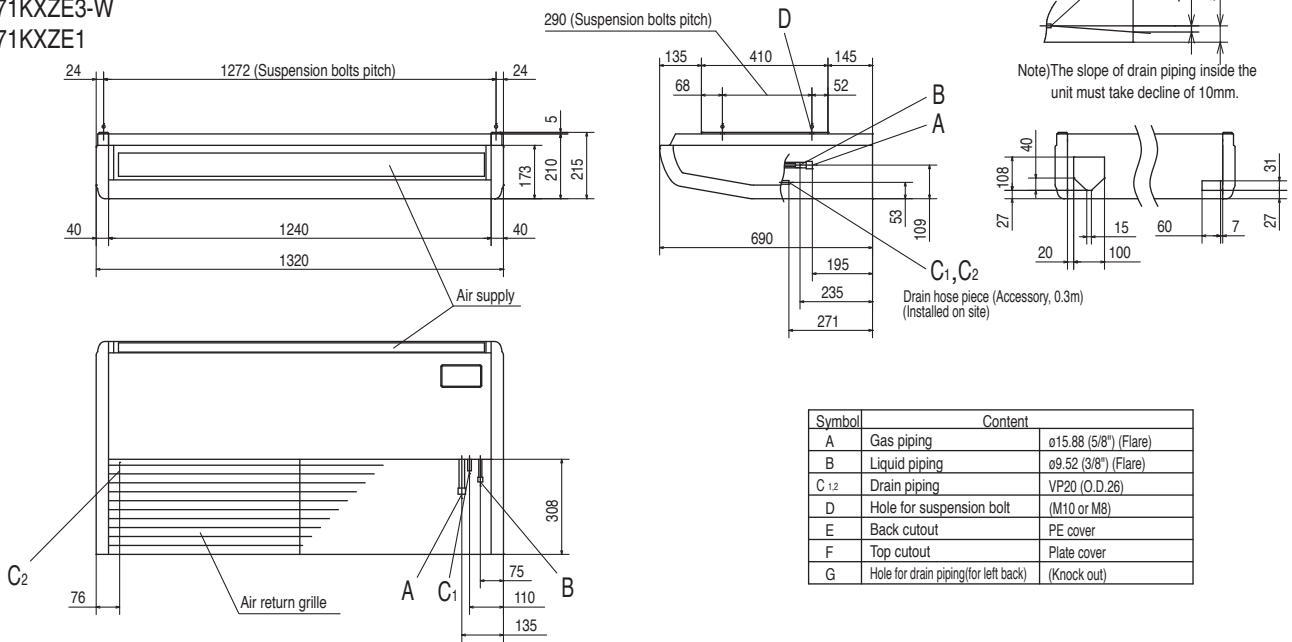

Make a space of 4000(36-56), 4500(71) or more between the units when installing more than one.

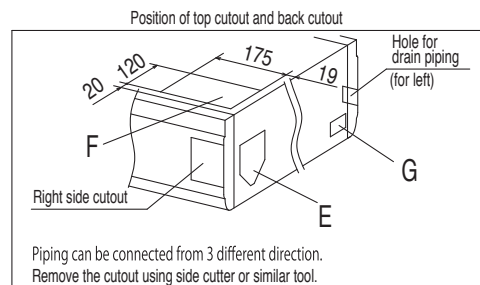

Note(1) The model name label is attached on the fan casing inside the air return grille.

# Ceiling Suspended FDE

FDE112KXZE3-W, FDE140KXZE3-W  
FDE112KXZE1, FDE140KXZE1

All measurements in mm.

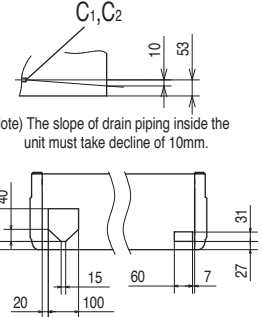
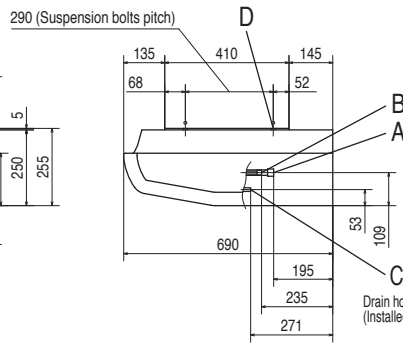
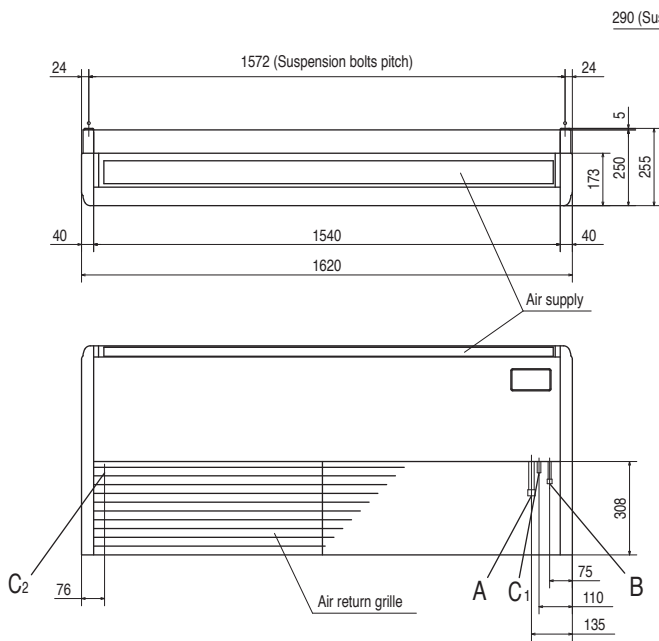

Symbol	Content	
A	Gas piping	ø15.88 (5/8") (Flare)
B	Liquid piping	ø9.52 (3/8") (Flare)
C1,2	Drain piping	VP20 (O.D.26)
D	Hole for suspension bolt	(M10 or M8)
E	Back cutout	PE cover
F	Top cutout	Plate cover
G	Hole for drain piping (for left back)	(Knock out)

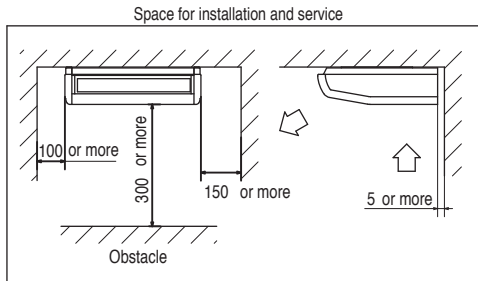

Make a space of 5000 or more between the units when installing more than one.

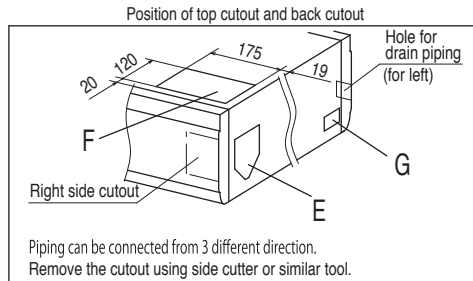

Piping can be connected from 3 different direction.  
Remove the cutout using side cutter or similar tool.

Note(1)The model name label is attached on the fan casing inside the air return grille.

# Floor Standing -2way- FDFW

FDFW28KXZE3-W, FDFW45KXZE3-W, FDFW56KXZE3-W  
FDFW28KXE6F, FDFW45KXE6F, FDFW56KXE6F

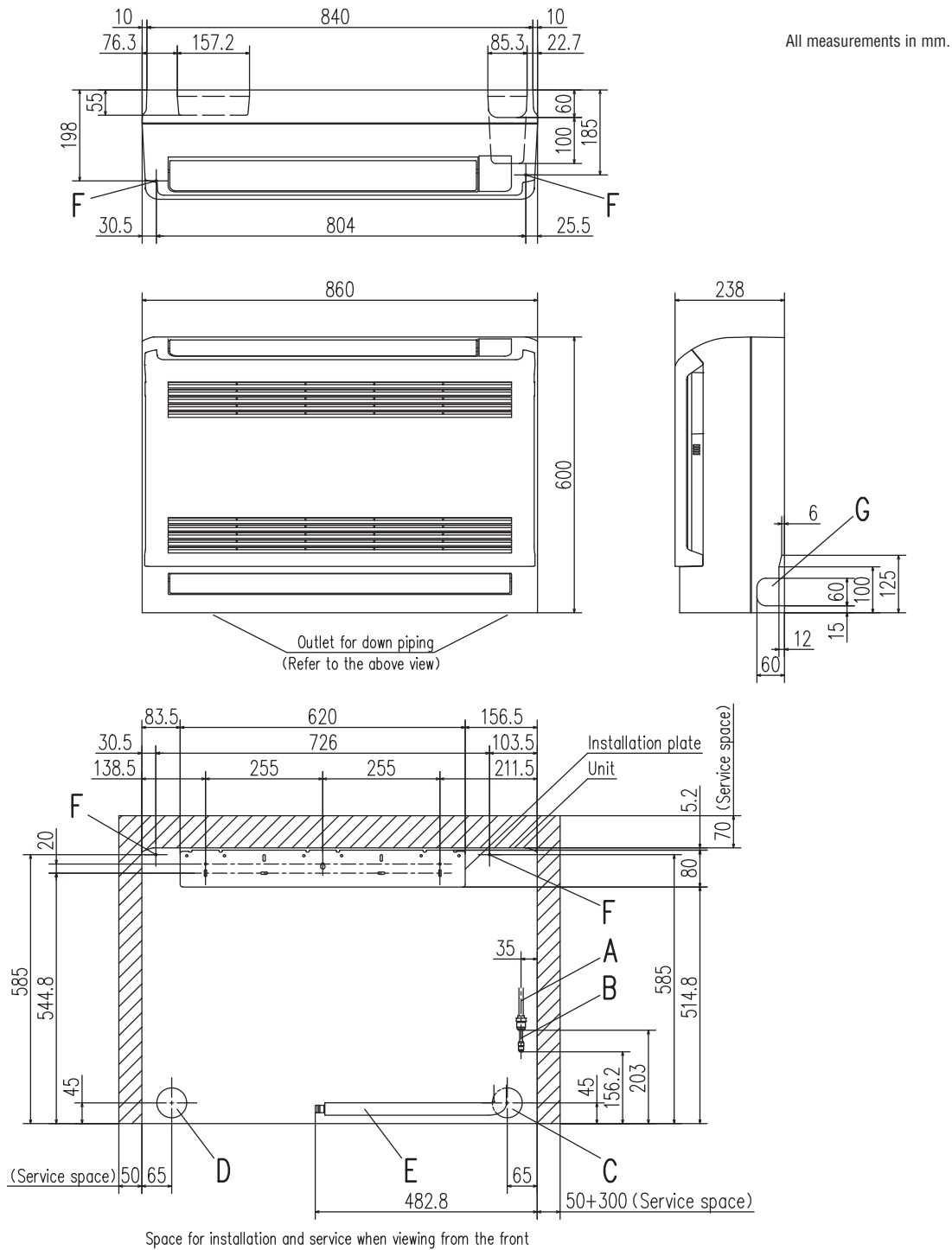

Symbol	Content		
	Model	28	45,56
A	Gas piping	φ9.52 (3/8") (Flare)	φ12.7 (1/2") (Flare)
B	Liquid piping	φ6.35 (1/4") (Flare)	
C	Hole on wall for right rear piping	(φ65)	
D	Hole on wall for left rear piping	(φ65)	
E	Drain hose	VP16 (O.D.22)	
F	Screw point fasten the indoor unit	φ5	
G	Outlet for piping (on both side)		

## Notes

- (1) The model name label is attached on the rightside of the unit.
- (2) In case of wall installation, leave the unit 150mm or less from the floor.

# Floor Standing (with casing) FDFL

FDFL71KXZE3-W

All measurements in mm.

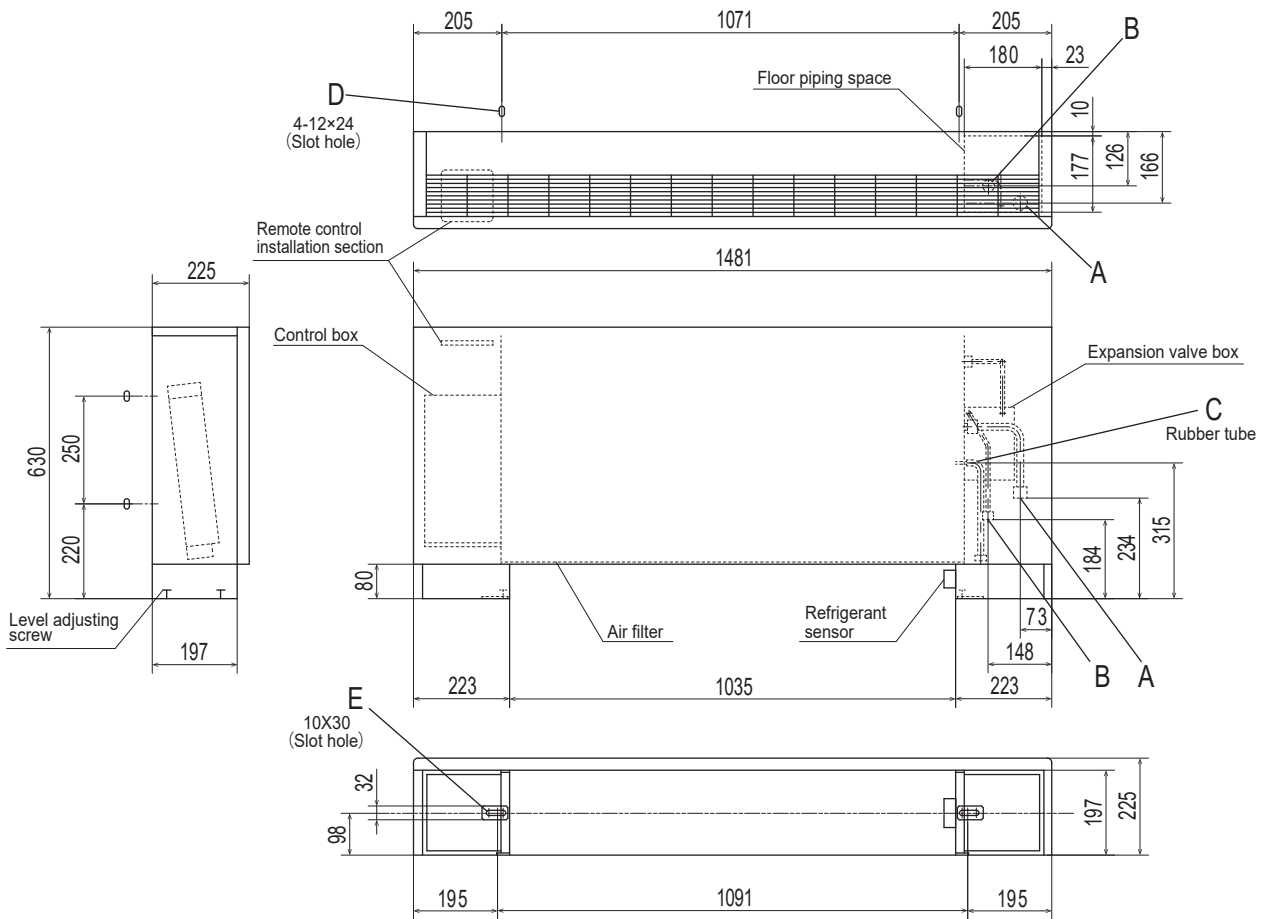

Space for installation and service

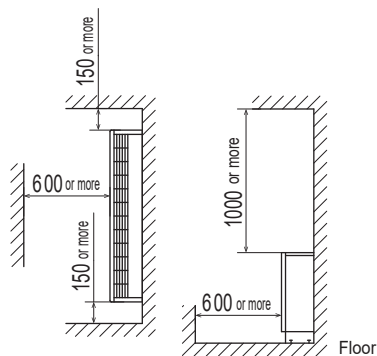

Symbol	Content	
A	Gas piping (Accessory)	φ 15.88 (5/8") (Flare)
B	Liquid piping	φ 9.52 (3/8") (Flare)
C	Drain piping (Accessory)	PT20A female screw
D	Slot hole for wall mounting	M10
E	Metal plate for floor mounting (Accessory)	M8

Note The model name label is attached on fan casing.

# Floor Standing (with casing) FDFL

FDFL71KXE6F

All measurements in mm.

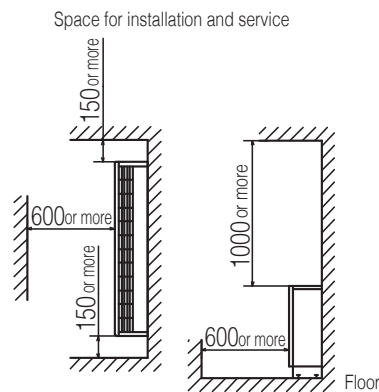
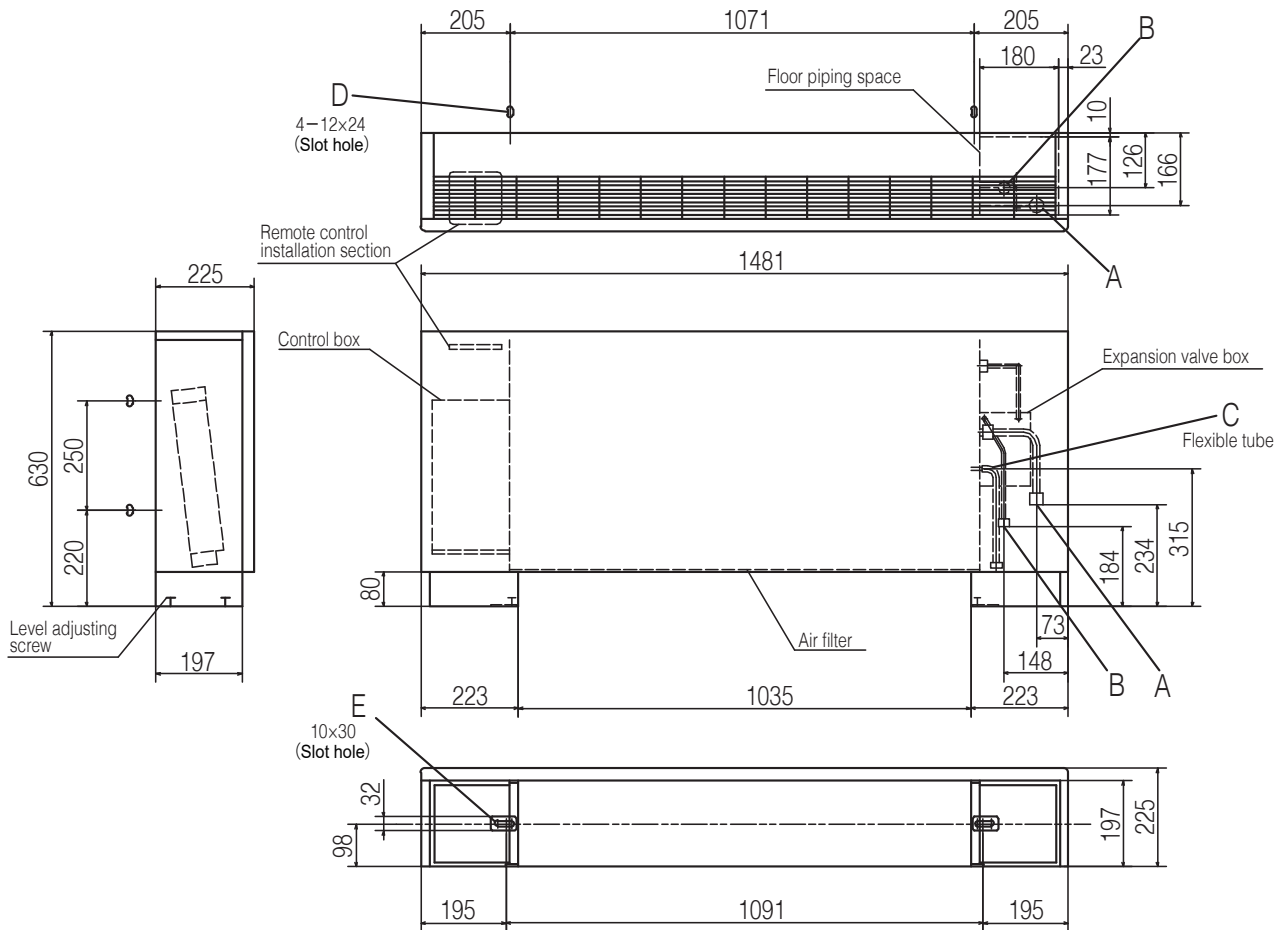

Symbol	Content	
A	Gas piping (Accessory)	$\phi$ 15.88 (5/8") (Flare)
B	Liquid piping	$\phi$ 9.52 (3/8") (Flare)
C	Drain piping (Accessory)	PT20A female screw, 360mm
D	Slot hole for wall mounting	(M10)
E	Metal plate for floor mounting (Accessory)	(M8)

Note The model name label is attached on the lid of the control box.

# Floor Standing (without casing) FDFU

FDFU28KXZE3-W, FDFU45KXZE3-W, FDFU56KXZE3-W

All measurements in mm.

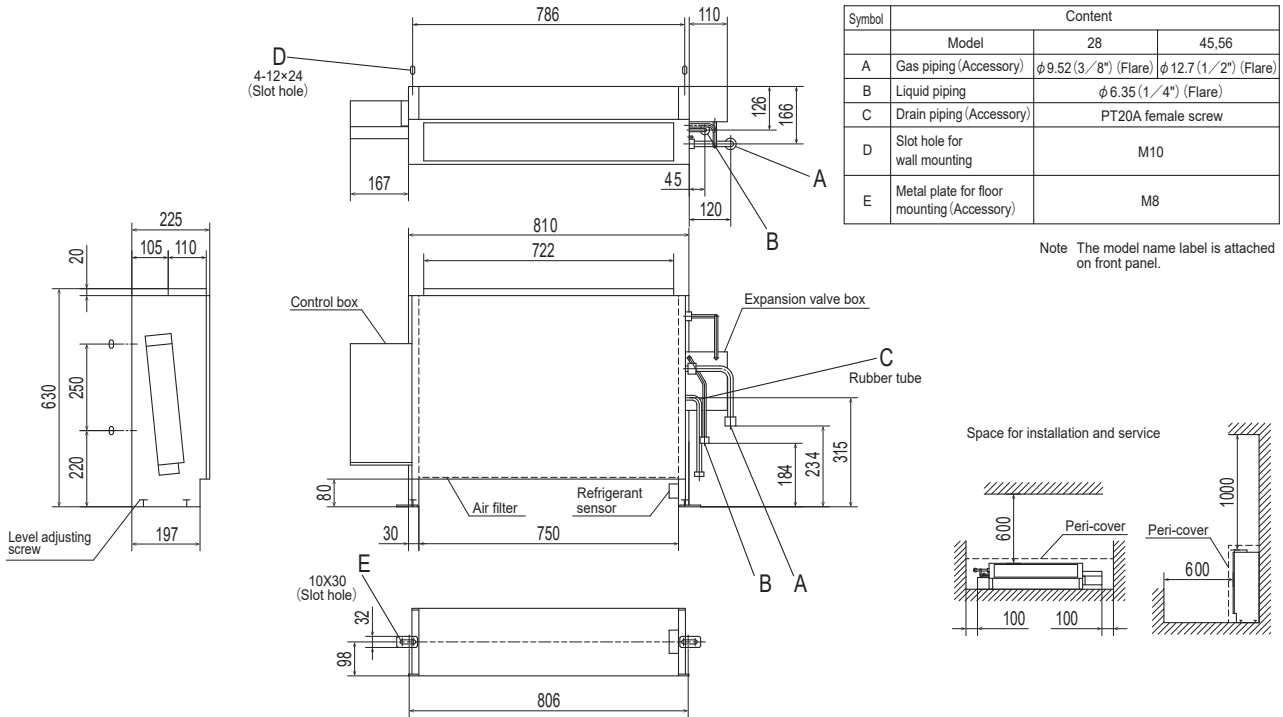

# FDFU71KXZE3-W

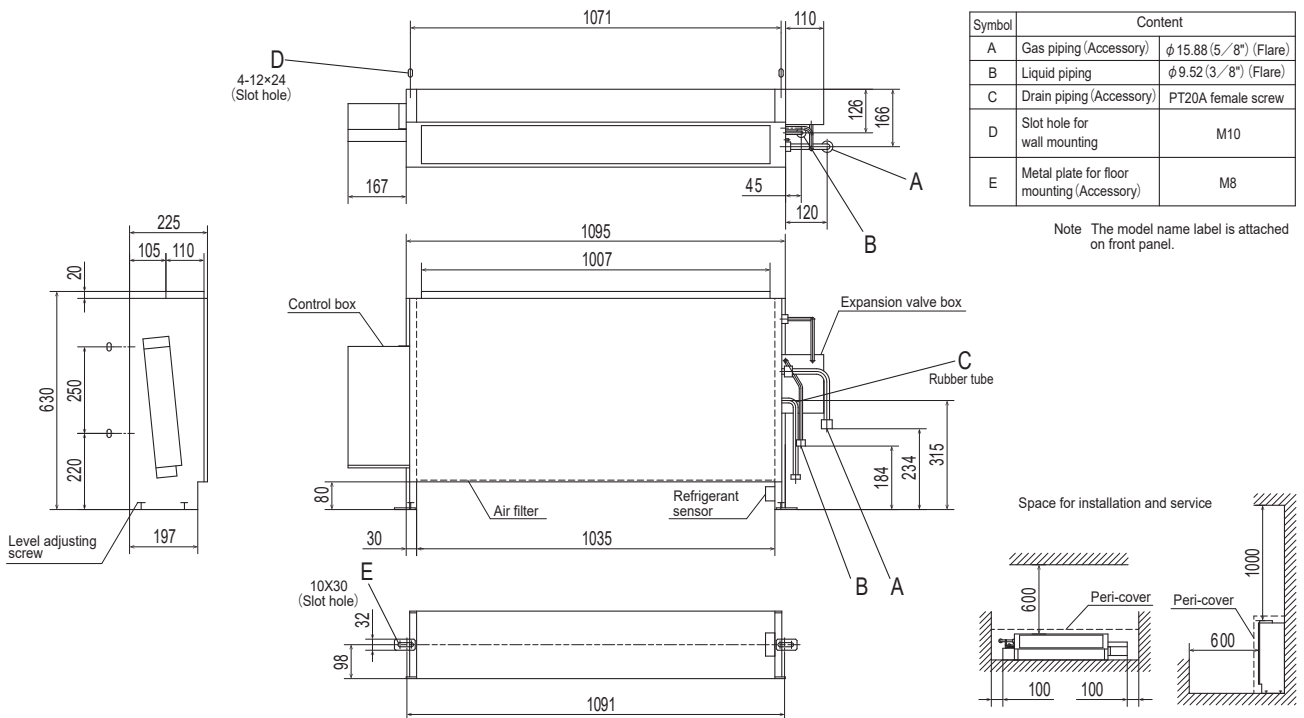

# Floor Standing (without casing) FDFU

FDFU28KXE6F, FDFU45KXE6F, FDFU56KXE6F

All measurements in mm.

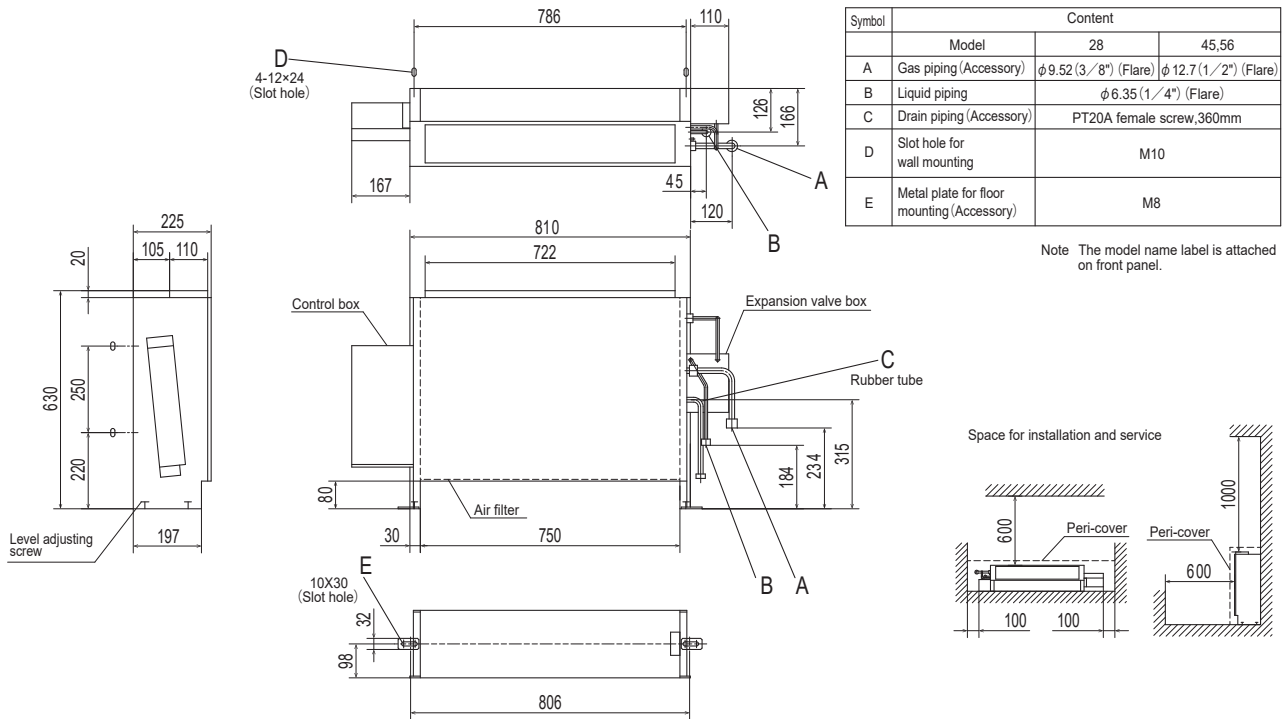

## FDFU71KXE6F

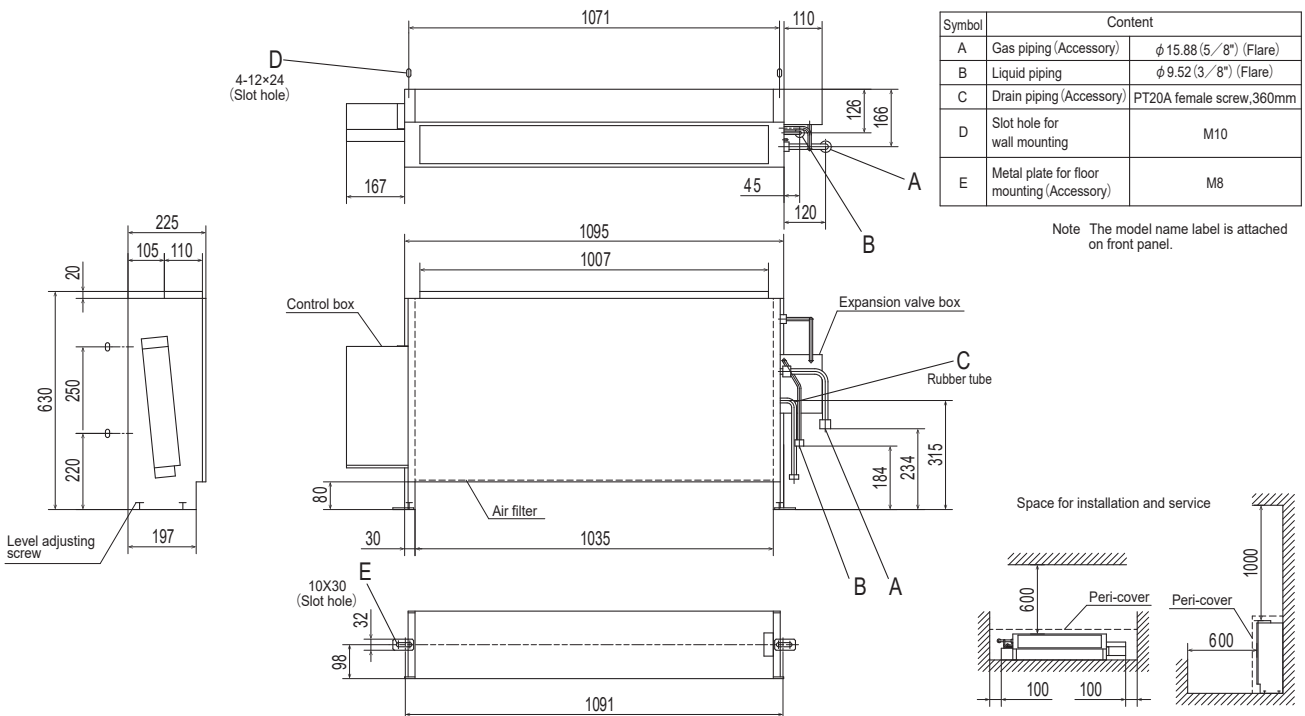

# Outdoor Air Processing unit FDU-F

FDU650FKXE3-W  
FDU650FKXE1

All measurements in mm.

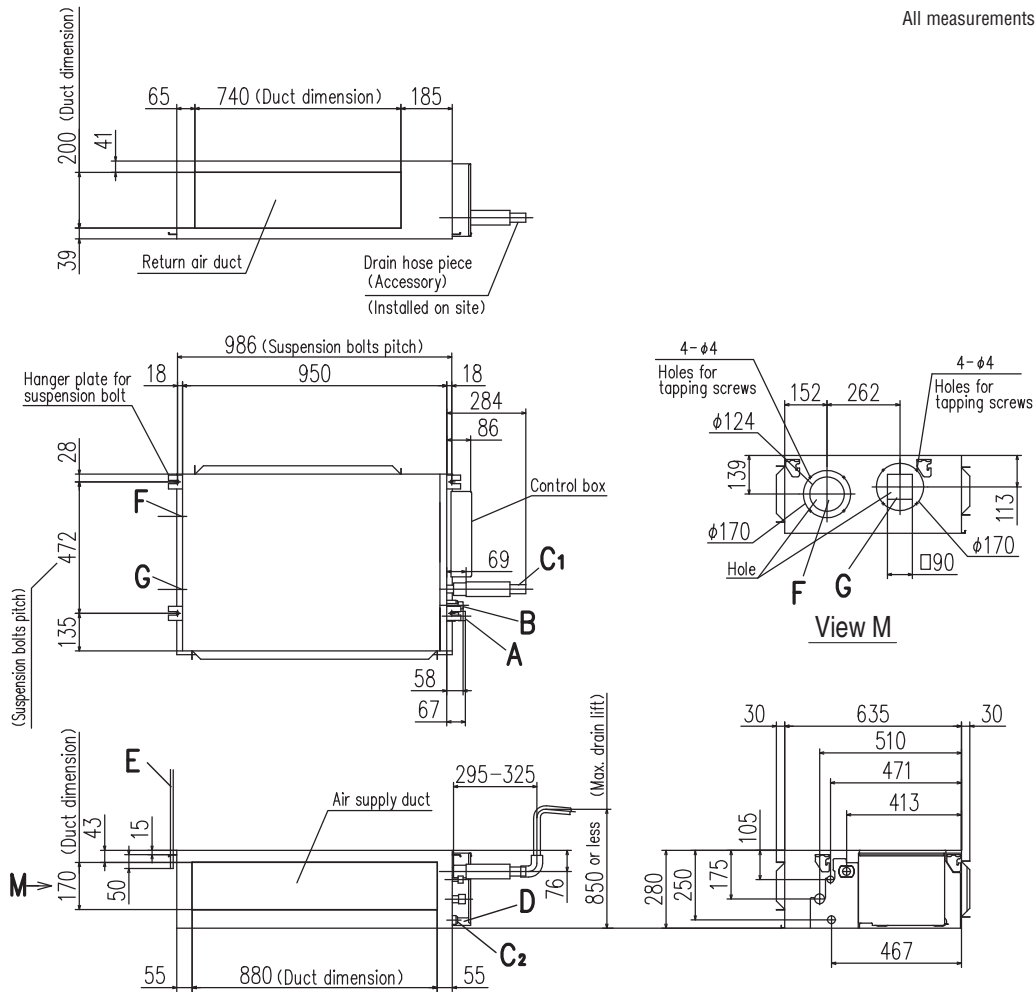

Symbol	Content	
A	Gas piping	ø15.88 (5/8") (Flare)
B	Liquid piping	ø9.52 (3/8") (Flare)
C1	Drain piping	VP25(O.D.32)
C2	Drain piping(Gravity drainage)	V20(O.D.26)
D	Hole for wiring	
E	Suspension bolts	M10
F	Outside air opening for ducting	(Knock out)
G	Air outlet opening for ducting	(Knock out)
H	Inspection opening	(450×450)

### Space for installation and service

Select either of two cases to keep space for installation and services.  
(Case 1) From side of unit

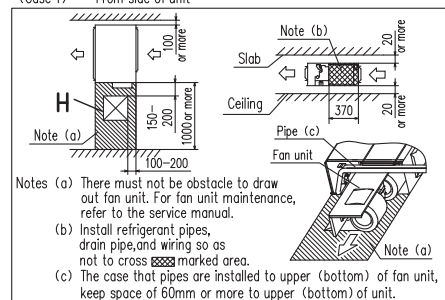

(Case 2) From bottom of unit

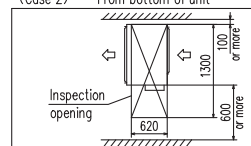

Note (1) The model name label is attached on the lid of the control box.

# Outdoor Air Processing unit FDU-F

FDU1100FKXZE3-W  
FDU1100FKXZE1

All measurements in mm.

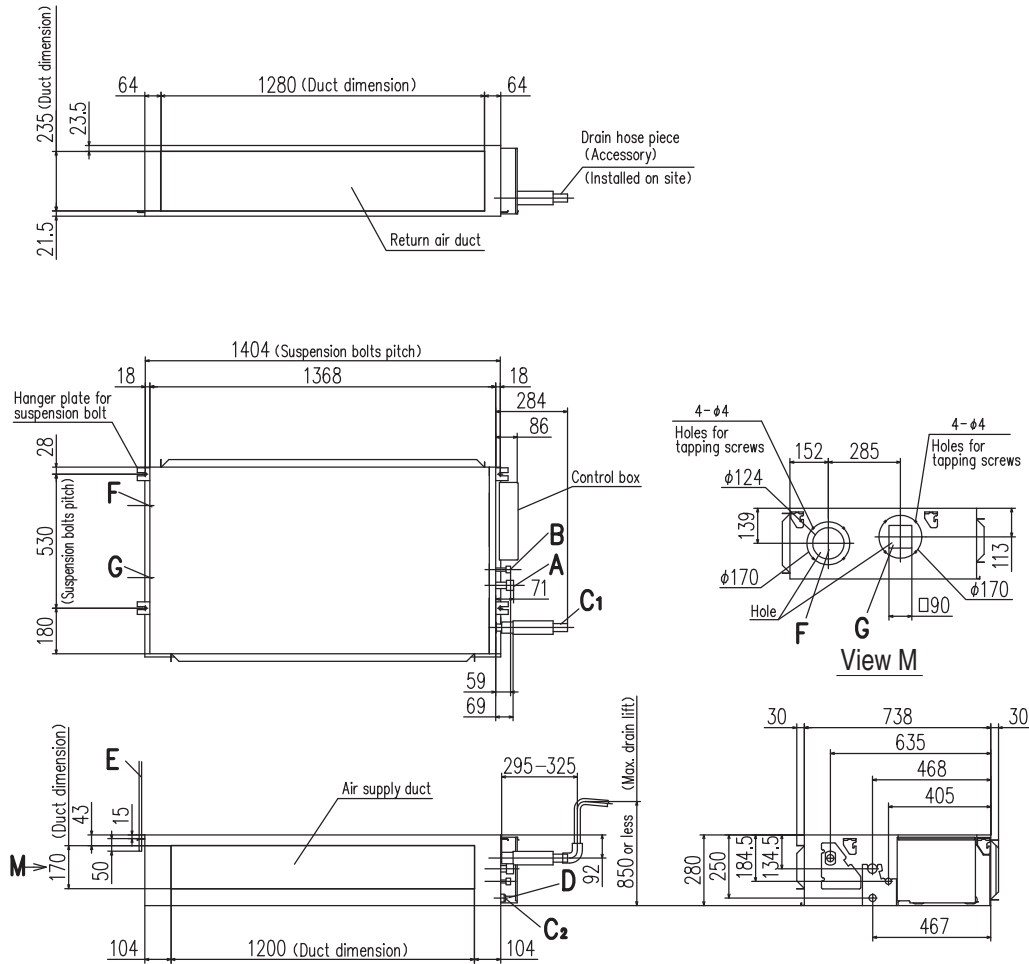

Symbol	Content	
A	Gas piping	ø15.88 (5/8") (Flare)
B	Liquid piping	ø9.52 (3/8") (Flare)
C1	Drain piping	VP25(O.D.32)
C2	Drain piping(Gravity drainage)	V20(O.D.26)
D	Hole for wiring	
E	Suspension bolts	M10
F	Outside air opening for ducting	(Knock out)
G	Air outlet opening for ducting	(Knock out)
H	Inspection opening	(450×450)

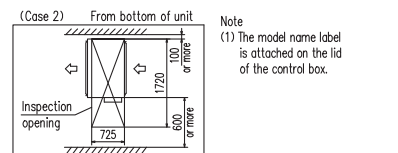
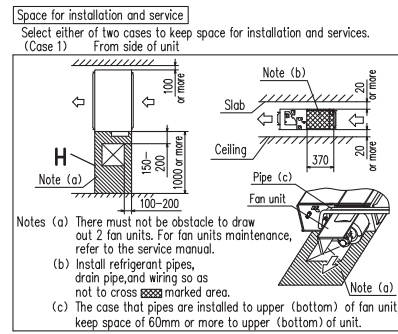

# Outdoor Air Processing unit FDU-F

FDU1800FKXE3-W, FDU2400FKXE3-W  
FDU1800FKXE1, FDU2400FKXE1

All measurements in mm.

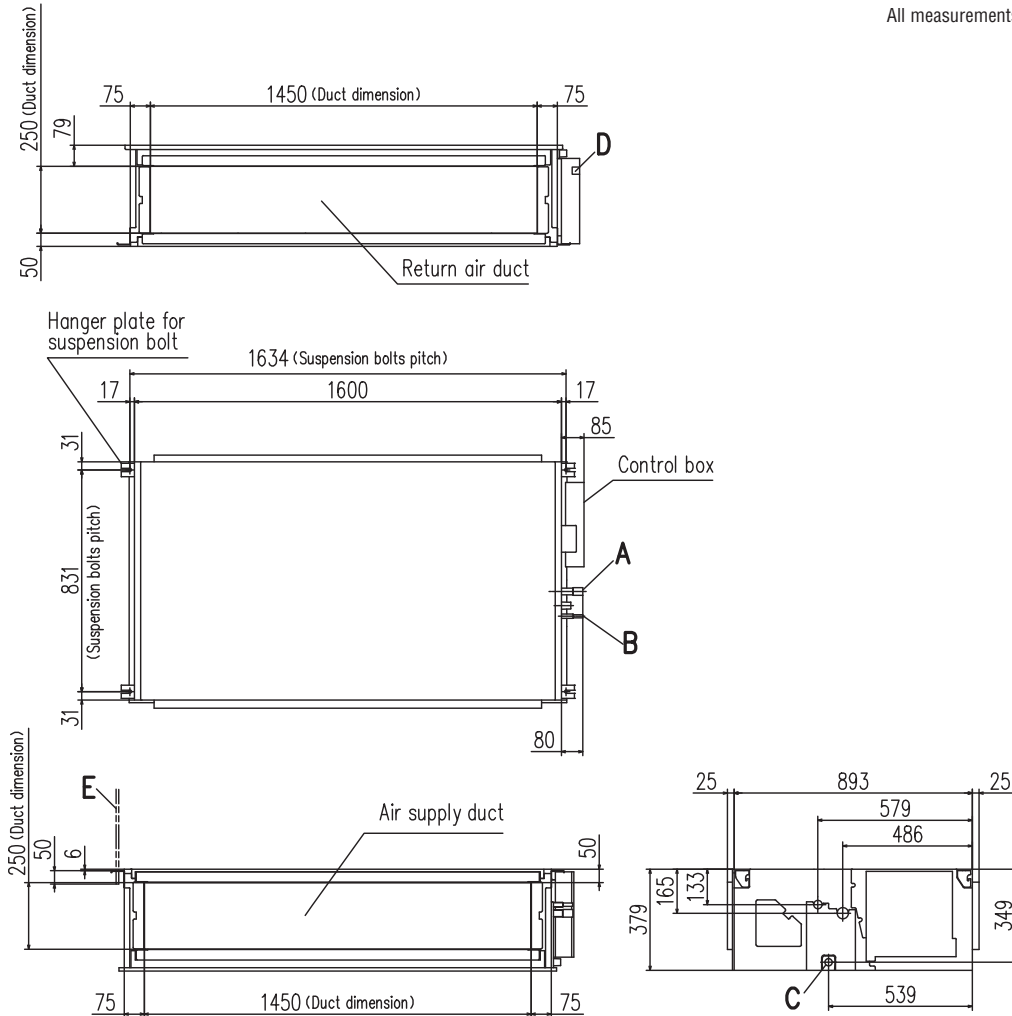

### Space for installation and service

Select either of two cases to keep space for installation and services.  
(Case 1) From side of unit

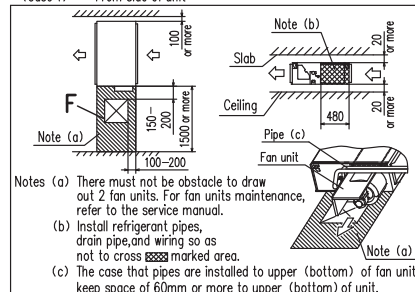

### (Case 2) From bottom of unit

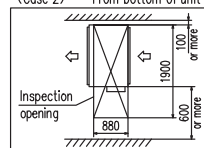

Notes (1) The model name label is attached on the lid of the control box.

Symbol	Content MODEL	1800	2400
A	Gas piping	ø19.05 (3/4") (Brazing)	ø22.22 (7/8") (Brazing)
B	Liquid piping	ø9.52 (3/8") (Brazing)	
C	Drain piping(Gravity drainage)	VP25(O.D.32)	
D	Hole for wiring		
E	Suspension bolts	M10	
F	Inspection opening	(450×450)	

# Hydro Module unit HMU

HMU140KXZE1, HMU280KXZE1

All measurements in mm.

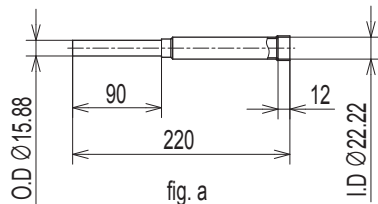
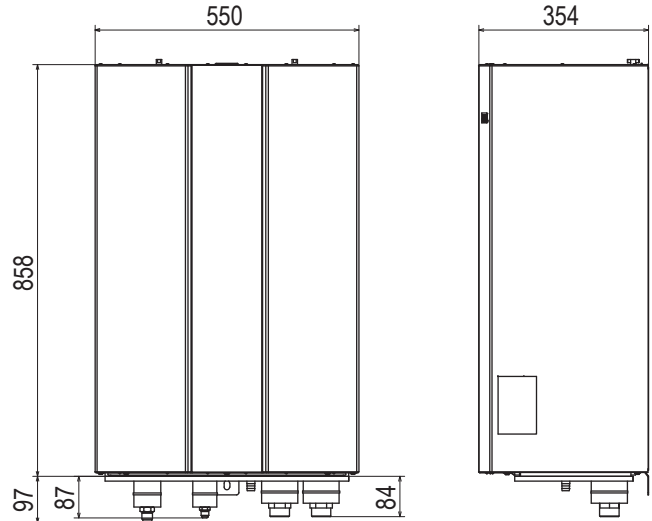
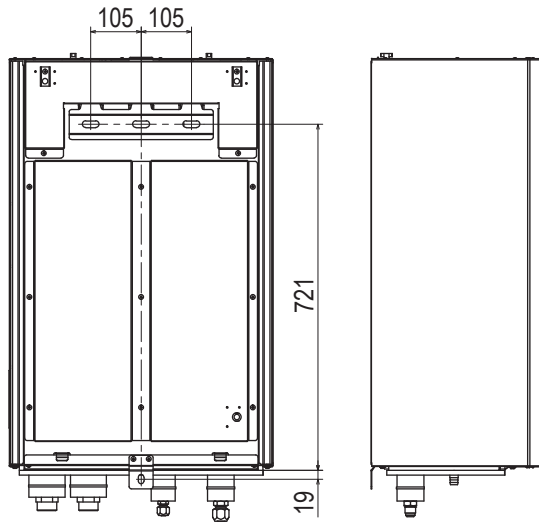

fig. a  
Scale : 1:5  
(Only for HMU280KXZE1)

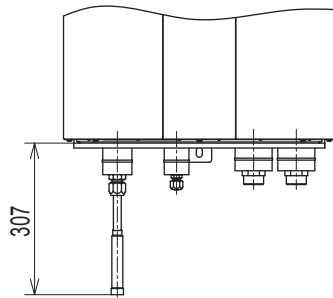
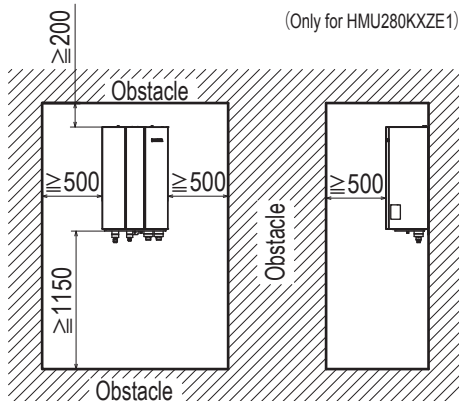
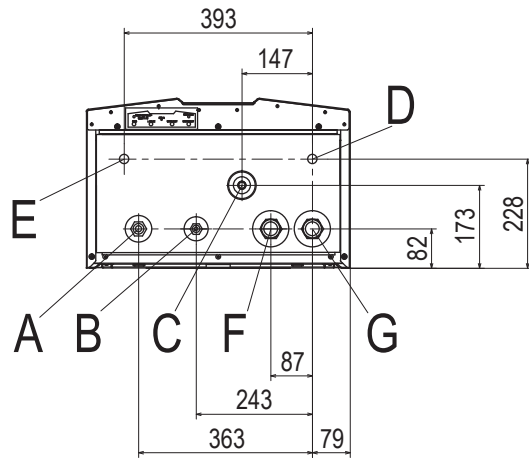

fig. b  
(Only for HMU280KXZE1)



Space for installation and service

Symbol	Content	MODEL	
		HMU140KXZE1	HMU280KXZE1
A	Gas piping	$\phi$ 15.88 (5/8") (Flare)	$\phi$ 15.88 (5/8") (Flare) ※1
B	Liquid piping	$\phi$ 9.52 (3/8") (Flare)	$\phi$ 9.52 (3/8") (Flare)
C	Drain socket (Gravity drainage)	PVC, $\phi$ 17 (O.D), t1.2	PVC, $\phi$ 17 (O.D), t1.2
D	Hole for power cable	$\phi$ 20	$\phi$ 20
E	Hole for signal line	$\phi$ 20	$\phi$ 20
F	Water inlet	PT1-1/4	PT1-1/4
G	Water outlet	PT1-1/4	PT1-1/4

※1 Accessory pipe (fig.a) needs to be connected for gas pipe on site.  
Therefore, the diameter of the gas pipe connected with the local piping is  $\phi$  22.22 (Brazing) (f ig.b).

# Fresh Air Ventilation and Heat Exchange unit SAF-E7

SAF150E7

All measurements in mm.

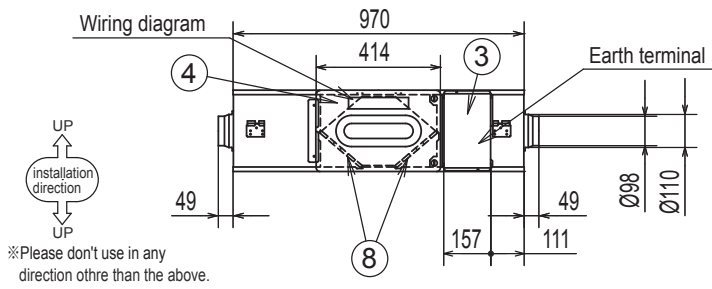
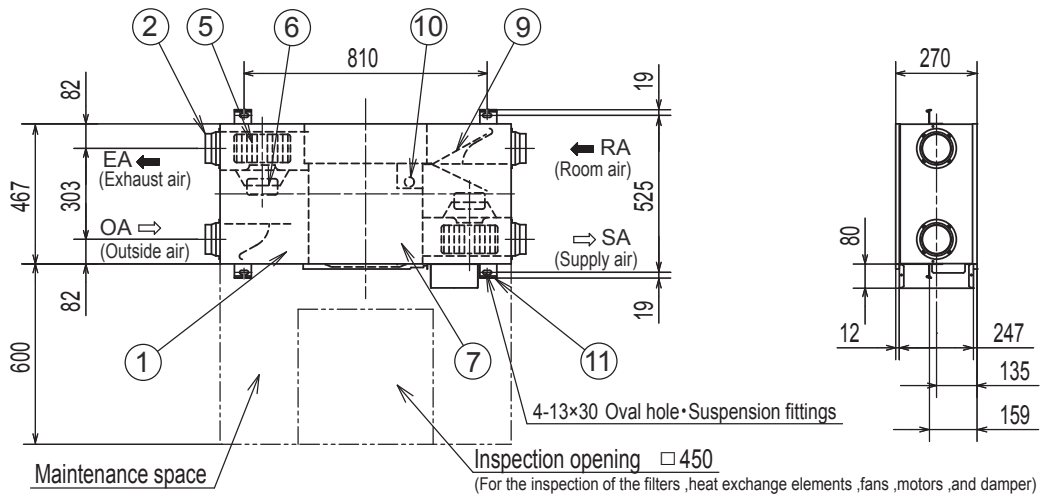

SAF250E7

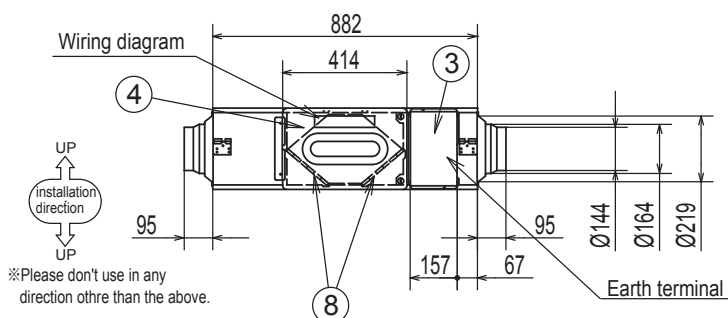
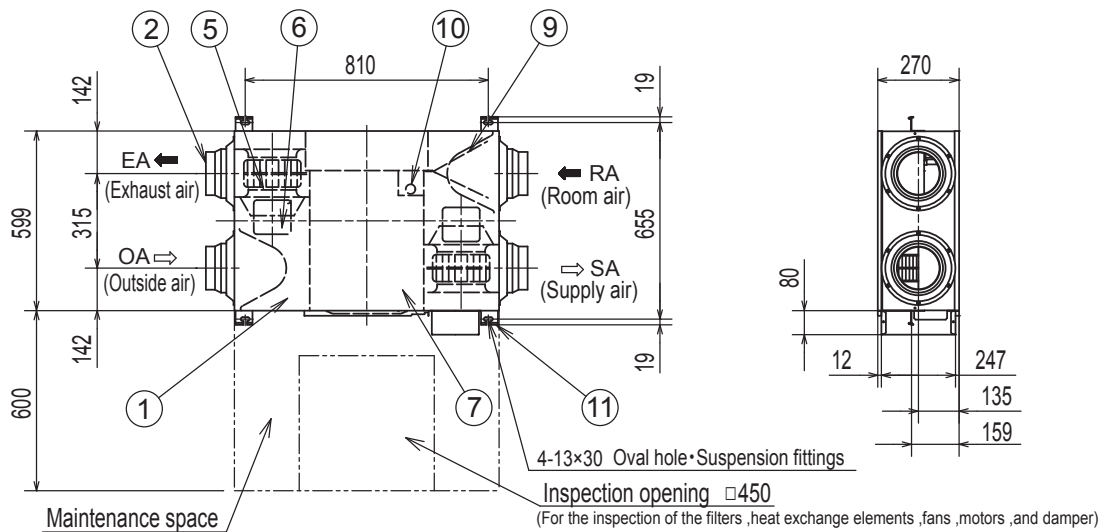



# Fresh Air Ventilation and Heat Exchange unit SAF-E7

SAF500E7

All measurements in mm.

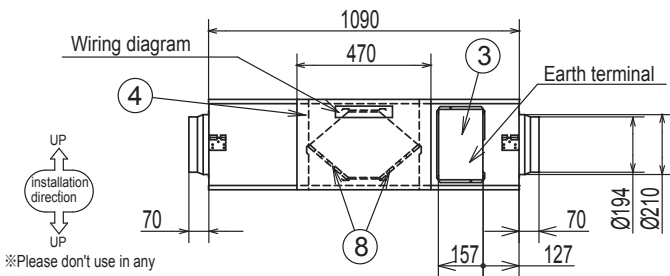
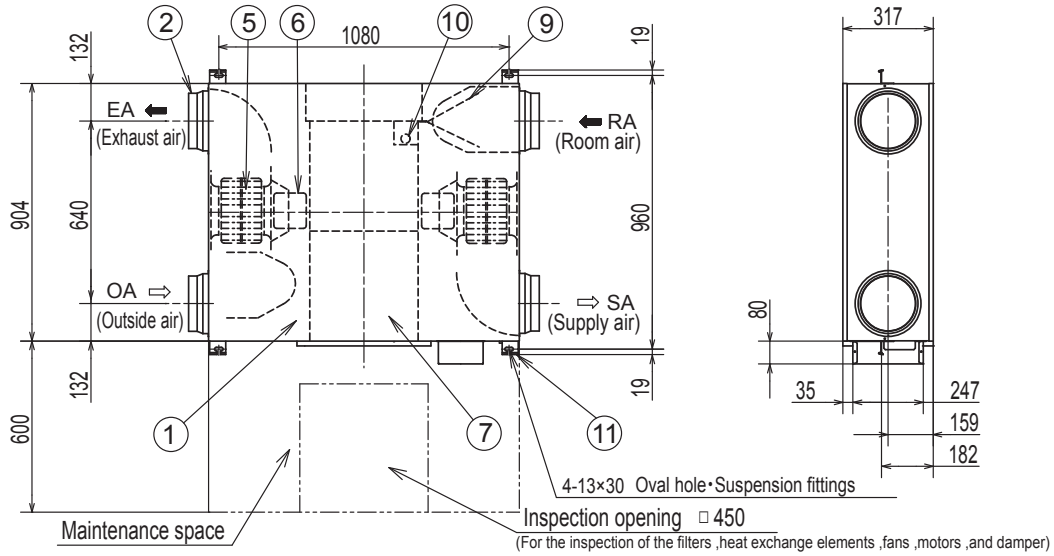

※Please don't use in any direction other than the above.

SAF800E7

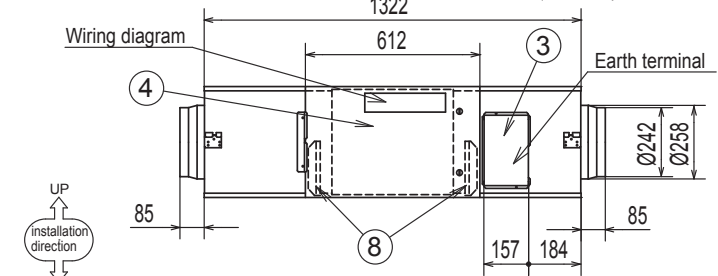
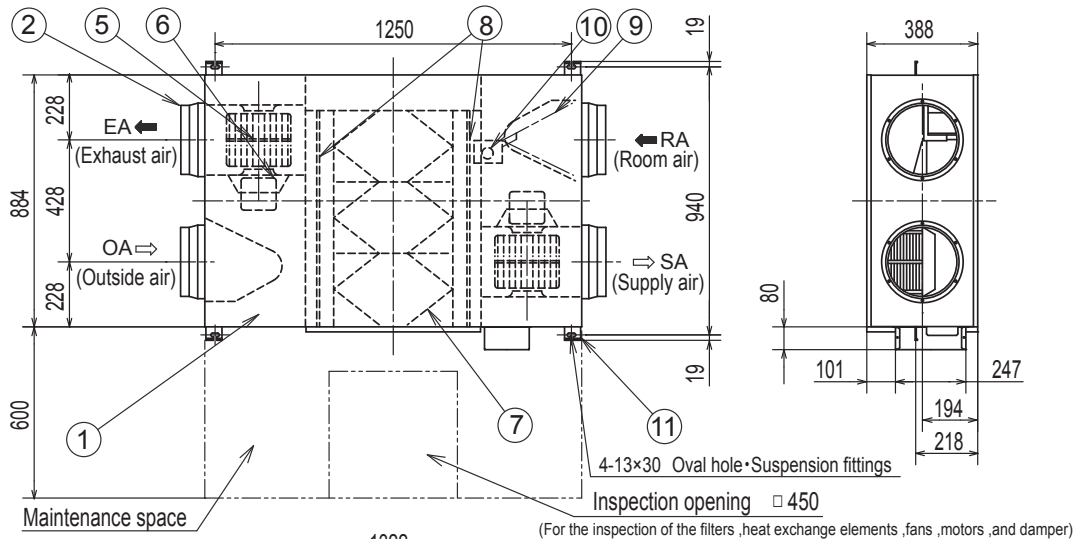

※ Please don't use in any direction other than the above.

# Fresh Air Ventilation and Heat Exchange unit SAF-E7

SAF1000E7

All measurements in mm.

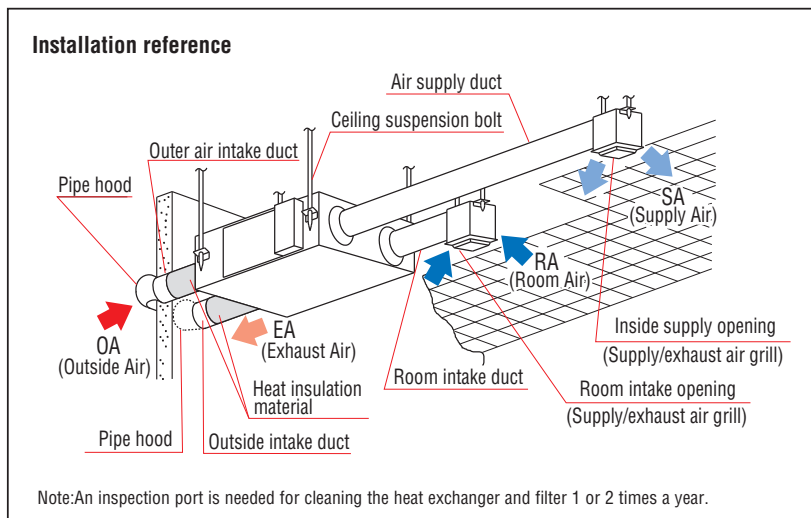
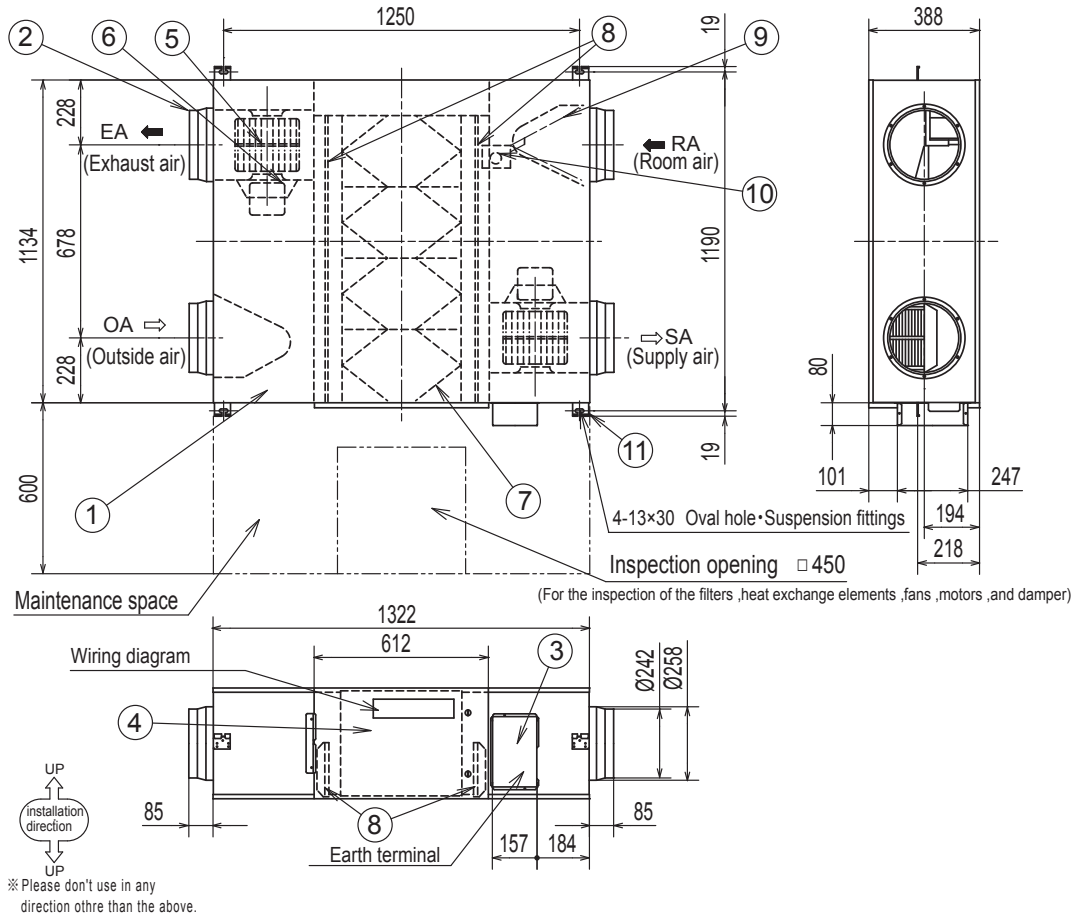

NO.	Name	Qt'y
①	Frame	1
②	Adaptor	4
③	Terminal board	1
④	Inspection Cover	1
⑤	Fan	2 ※
⑥	Motor	2 ※
⑦	Heat Exchange Element SAF500E7 SAF800E7 SAF1000E7	2 3 4
⑧	Filter	2
⑨	Damper	1
⑩	Damper Motor	1
⑪	Suspension fitting	4
⑫	Electrical components box	1

※ Model SAF500E7 have different fan and motor locations.

# Fresh Air DX Assembly SAF-DX

SAF-DX250E6, SAF-DX350E6

All measurements in mm.

Symbol	Content	
A	Gas piping	φ9.52 (3/8") (Flare)
B	Liquid piping	φ6.35 (1/4") (Flare)
C	Drain piping	R1
D	Hole for power source line	
E	Wiring hole for total enthalpy heat exchanger	
F	Hole for communication line	
G	Suspension bolts	M10

## Space for installatin and service

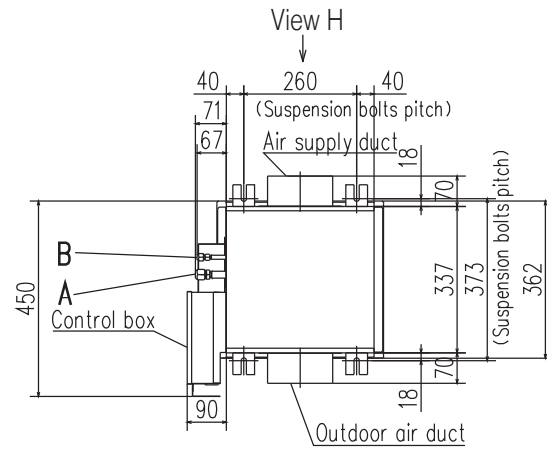
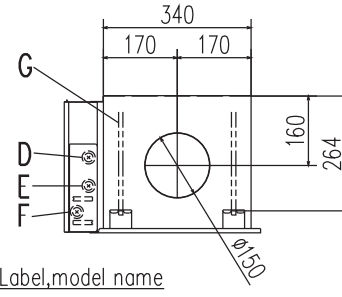
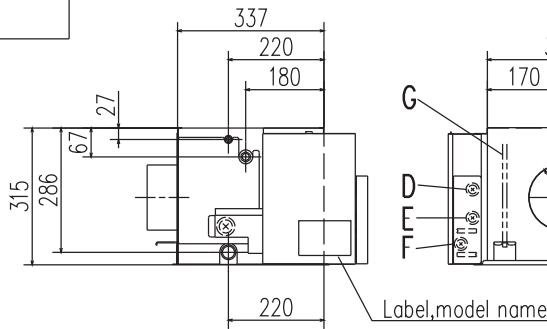
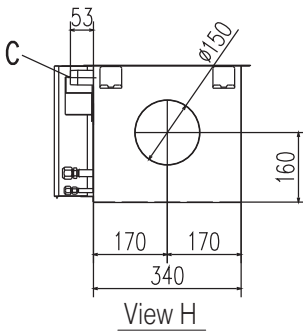
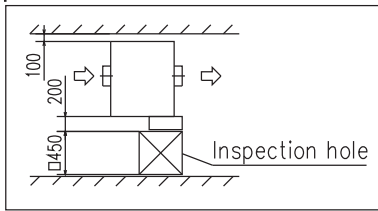

SAF-DX500E6

Symbol	Content	
A	Gas piping	φ12.7 (1/2") (Flare)
B	Liquid piping	φ6.35 (1/4") (Flare)
C	Drain piping	R1
D	Hole for power source line	
E	Wiring hole for total enthalpy heat exchanger	
F	Hole for communication line	
G	Suspension bolts	M10

## Space for installatin and service

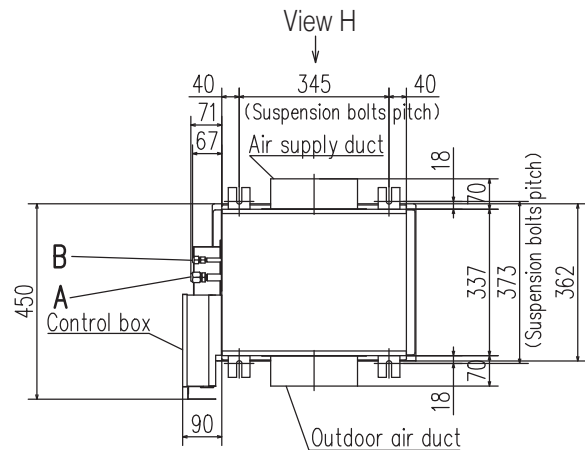
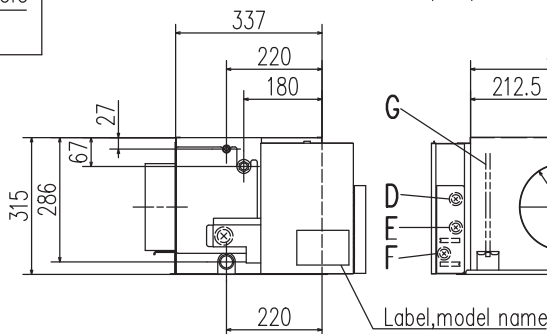
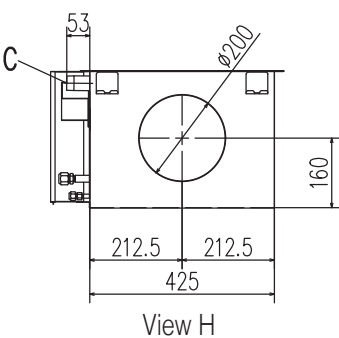
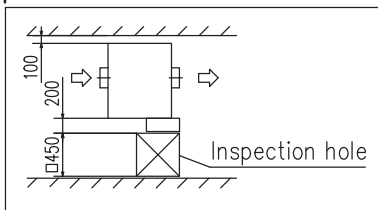

# Fresh Air DX Assembly SAF-DX

SAF-DX800E6

All measurements in mm.

Symbol	Content	
A	Gas piping	φ12.7 (1/2") (Flare)
B	Liquid piping	φ6.35 (1/4") (Flare)
C	Drain piping	R1
D	Hole for power source line	
E	Wiring hole for total enthalpy heat exchanger	
F	Hole for communication line	
G	Suspension bolts	M10

## Space for installatin and service

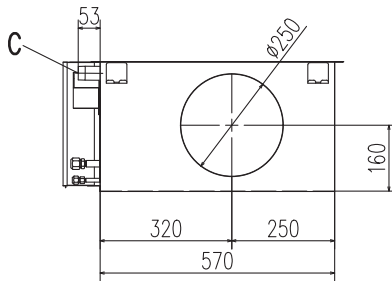
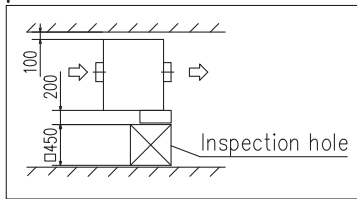

View H

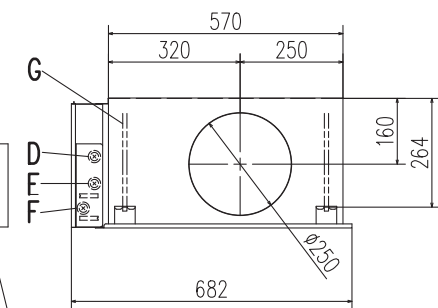
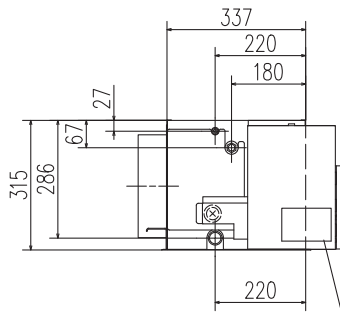

Label,model name

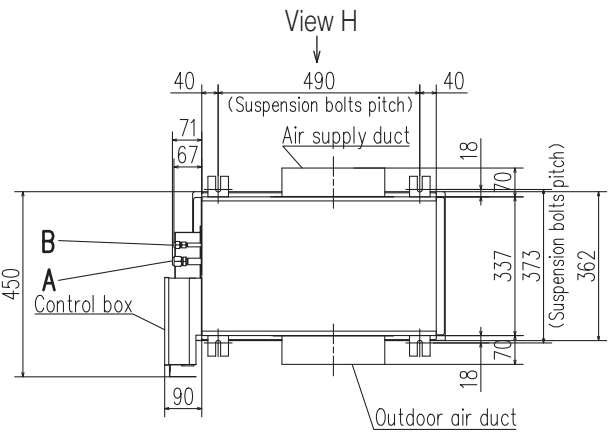

SAF-DX1000E6

Symbol	Content	
A	Gas piping	φ15.88 (5/8") (Flare)
B	Liquid piping	φ9.52 (3/8") (Flare)
C	Drain piping	R1
D	Hole for power source line	
E	Wiring hole for total enthalpy heat exchanger	
F	Hole for communication line	
G	Suspension bolts	M10

## Space for installatin and service

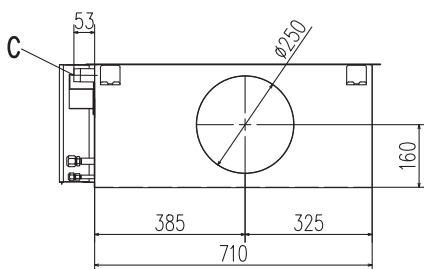
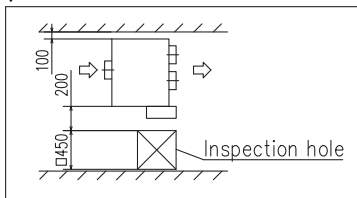

View H

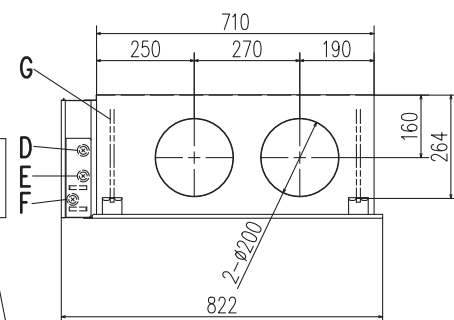
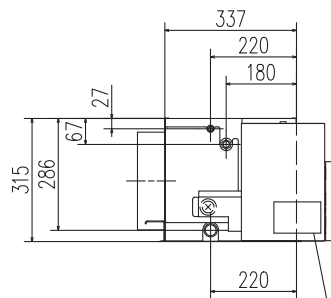

Label,model name

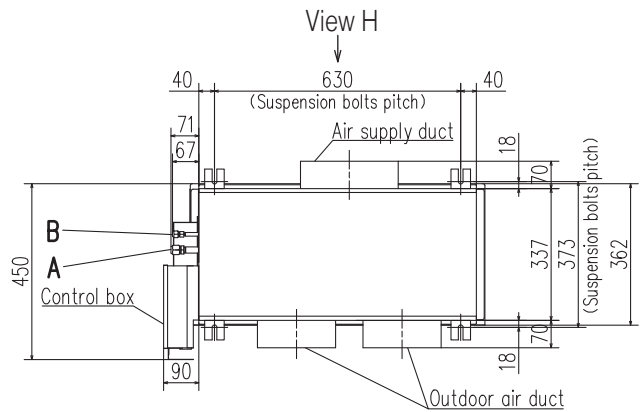

## Before starting use

### Heating performance

The heating performance values (kW) described in the catalogue are the values obtained by operating at an outdoor temperature of 7°C and indoor temperature of 20°C as set forth in the ISO Standards. Heating performance is reduced as the temperature drops. If the outdoor temperature is too low and the heating performance is insufficient, use other heating appliances as well.

### Indication of sound values

The sound values are the values (A scale) measured in a chamber such as an anechoic chamber following the ISO Standards. In the actual installation state, the value is normally larger than the values given in the catalogue due to the effect of surrounding noise and echo. Take this into consideration when installing.

### Use in oil atmosphere

Avoid installing this unit in an atmosphere where oil scatters or builds up, such as in a kitchen or machine factory.

If the oil adheres to the heat exchanger, the heat exchanging performance will drop, mist may be generated, and the synthetic resin parts may deform and break.

### Use in acidic or alkaline atmosphere

If this unit is used in acidic atmosphere such as hot spring areas having high level of sulfuric gases or in alkaline atmosphere including ammonia or calcium chloride, places where the exhaust of the heat exchanger is sucked in, or at coastal areas where the unit is subject to salt breezes, the outer plate or heat exchanger, etc., will corrode. Please ask a dealer or specialist when you use an air-conditioner in places differing from a general atmosphere.

### Use in places with high ceilings

If the ceiling is high, install a circulator to improve the heat and air flow distribution when heating.

### Refrigerant leakage

The refrigerant (R32, R410A) used for air-conditioner is non-toxic and in its original state.

However, in consideration of a state where the refrigerant leaks into the room, measures against refrigerant leaks must be taken in small rooms where the tolerable level could be exceeded. Take measures by installing ventilation devices, etc.

### Use in snowy areas

Take the following measures when installing the outdoor unit in snowy areas.

#### · Snow prevention

Install a snow-prevention hood so that the snow does not obstruct the air intake port or enter and freeze in the outdoor unit.

#### · Snow piling

In areas with heavy snow fall, the piled snow could block the air intake port. In this case, a frame that is 50cm or higher than the estimated snow fall must be installed underneath the outdoor unit.

### Automatic defrosting device

If the temperature is low, and the humidity is high, frost will stick to the heat exchanger of the outdoor unit. If continued to use, the heating performance will drop.

The "Automatic defrosting device" will function to remove this frost.

After heating for approx. three to ten minutes, it will stop, and the frost will be removed. After defrosting, hot air will be blown again.

### Servicing

After the air-conditioner has been used for several seasons, dirt will build up in the air-conditioner causing the performance to drop. In addition to regular servicing, a maintenance contract by a specialist is recommended.

## Safety Precautions

### Air-conditioner usage target

The air-conditioner described in this catalogue is a dedicated cooling/ heating device for human use.

Do not use it for special applications such as the storage of food items, animals or plants, precision devices or valuable art, etc.

This could cause the quality of the items to drop, etc.

Do not use this for cooling vehicles or ships. Water leakage or current leaks could occur.

### Before use

Always read the "User's Manual" thoroughly before starting use.

### Installation

Always commission the installation to a dealer or specialist. Improper installation will lead to water leakage, electric shocks and fires.

Make sure that the outdoor unit is stable in installation. Fix the unit to stable base.

### Usage place

Do not install in places where combustible gas could leak or where there are sparks. Installation in a place where combustible gas could be generated, flow or accumulate, or places containing carbon fibers could lead to fires.

### Certified ISO 9001



JQA-0709

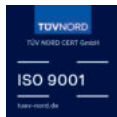

Mitsubishi Heavy Industries - Mahajak Air Conditioners Co., Ltd. has been certified of Quality Management System in accordance with ISO 9001 by TUV NORD (Thailand) Ltd.



Mitsubishi Heavy Industries Thermal Systems, Ltd. Participate in the Eurovent certification program for variable refrigerant flow (VRF). Check ongoing validity of certificate: [www.eurovent-certification.com](http://www.eurovent-certification.com)

### Certified ISO 14001

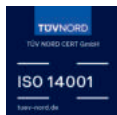

Mitsubishi Heavy Industries - Mahajak Air Conditioners Co., Ltd. has been certified of Environmental Management System in accordance with ISO 14001 by TUV NORD (Thailand) Ltd.



## Mitsubishi Heavy Industries Thermal Systems, Ltd.

2-3, Marunouchi 3-chome, Chiyoda-ku, Tokyo, 100-8332, Japan

<https://www.mhi-mth.co.jp/en/>

Because of our policy of continuous improvement, we reserve the right to make changes in all specifications without notice.

26KX01E-A March 2026 F Edited in Japan